

THESIS FOR THE DEGREE OF DOCTOR OF PHILOSOPHY

Voltage Control and Voltage Stability of
Power Distribution Systems in the
Presence of Distributed Generation

by

FERRY AUGUST VIAWAN



Division of Electric Power Engineering
Department of Energy and Environment
CHALMERS UNIVERSITY OF TECHNOLOGY
Göteborg, Sweden 2008

**Voltage Control and Voltage Stability of Power Distribution Systems
in the Presence of Distributed Generation**

FERRY AUGUST VIAWAN

ISBN 978-91-7385-060-5

© FERRY AUGUST VIAWAN, 2008.

Doktorsavhandlingar vid Chalmers tekniska högskola

Ny serie nr. 2741

ISSN 0346-718X

Division of Electric Power Engineering

Department of Energy and Environment

Chalmers University of Technology

SE-412 96 Göteborg

Sweden

Phone: +46-31-772 1000

Chalmers Bibliotek, Reproservice

Göteborg, Sweden 2008

To

My parents

My wife and our daughter

Abstract

This thesis presents an analysis of voltage control and voltage stability in distribution systems, in the presence of distributed generation (DG). The steady state voltage and reactive power control in distribution systems without and with the presence of synchronous and induction machines DG, are evaluated for various possible operation characteristics of the DG. The impact of the DG on various voltage stability mechanisms is investigated.

Overall, the results show that DG affects, positively or negatively, the steady state voltage and reactive power control as well as the voltage stability margin in distribution systems. The type and the operation characteristics of the DG affect the influence on the control and stability. If the DG is properly coordinated with the available voltage and reactive power equipment, a proper voltage regulation can still be maintained with the presence of DG. Further, the negative impact of DG on voltage stability can be mitigated with proper reactive power compensation devices.

The steady state voltage and reactive power control in distribution systems can be properly controlled by coordinating the available voltage and reactive power control equipment, such as on-load tap-changers, substation shunt capacitors and feeder shunt capacitors that are considered in the thesis. In the thesis, a simple method is derived to achieve coordinated control by determining the optimum set points of the equipment from off line calculation and letting the equipment operate based on local measurements.

DG alters the power flow and the voltage profile in the distribution systems. This calls for readjustment of the voltage and reactive power control in the distribution system. The DG operation characteristics affect the power flow and voltage alteration. The specific readjustments needed are illustrated in the thesis, both for the case with synchronous machine DG and for the case with induction machine DG.

DG may increase the risks of undervoltage/overvoltage. These risks can be reduced, or even be mitigated, if the voltage and reactive power control equipment are operated based on a coordinated control using forecasting, optimization and remote control. The implementation of this coordinated control to the distribution systems with DG is proposed in the thesis. Both cases with and without DG involved in the voltage control are presented. The benefit of the coordinated control to the economic and secure operation of the distribution system is also illustrated.

Minimizing reactive power flow to the distribution systems will increase the maximum active power transfer capability to the distribution systems. Referring to this, stand-by reactive power sources are needed in addition to

the available capacitors for loss minimization, in order to maintain the voltage stability in the distribution systems. The type of voltage instability mechanism defines the type of reactive power compensation needed, which is analyzed in the thesis.

Finally, DG generating reactive power offers a potential to improve the voltage stability in the distribution system, meanwhile DG absorbing reactive power can degrade it. This topic is also examined in the thesis, and the role of different reactive power devices in mitigating the impact of DG on the deterioration of the voltage stability is presented.

Keywords: distributed generation, voltage control, reactive power control, voltage stability, distribution system, on-load tap-changer, shunt capacitor, synchronous machine, induction machine.

Acknowledgement

This work has been carried out since January 2004, at the Division of Electric Power Engineering, Department of Energy and Environment, Chalmers University of Technology. The first part of the project, up to Licentiate, has been financed by Göteborg Energi Research Foundation and the second part by the Department of Energy and Environment, Chalmers University of Technology. The financial supports are gratefully acknowledged.

I would like to express my sincere gratitude to my supervisor Dr. Daniel Karlsson for guiding me, to do the research on the right track, both on practical and scientific manners. Sincere gratitude also goes to Prof. Gustaf Olsson for examining the work and for many fruitful discussions. I am very grateful to both of them, for their valuable suggestions and, especially, for their great effort in reading the manuscript on irregular hours and giving feedbacks well in time.

I would also like to express my deepest gratitude to Dr. Ambra Sannino and Prof. Jaap Daalder, the supervisor and the examiner of the first part of the work, for giving me a great opportunity to undertake PhD study at the Division of Electric Power Engineering. Thanks also for their guidance and support in the first part of the project.

Many thanks go to all colleagues at old-Elteknik for providing a friendly working environment. In particular, I want to thank Abram Perdana for a good companionship and for all nice discussions.

Similarly, I also got a nice working environment at the Power Technologies Department, ABB Corporate Research, Västerås. Thanks to my colleagues there. Special thanks to Dr. Ambra Sannino for all her helps, Dr. Stefan Thorburn for the technical discussions, to Dr. Gabriel Olguin, Dr. Muhamad Reza and Dr. Waqas Arshad for the free time discussions, and to Dr. Jianping Wang for sharing his experiences. I am very grateful to Dr. Mikael Dahlgren for giving me opportunity to start working at ABB one year before I completed my PhD.

My Indonesian friends in Göteborg and Västerås have made living in Sweden enjoyable for me and for my family. Thanks a lot for the wonderful brotherhood and friendship. Thanks all Indonesian students in Göteborg for easily helping me and my family when we needed.

Last but not least, I would like to express my ultimate gratitude to my parents and my parents in law for their endless prays and their outstanding support. Heartfelt thanks go to my wife Ida Rose and our daughter Kayyisah Amada. Thanks to my wife for her encouragement in the decision of back to

school, betting with uncertainty after several years working and living in certainty; and for her continuous support in the most difficult times during the period of the study. Thanks for the patient of my beloved daughter. I feel sorry that, in the last one year of the PhD study, regularly I have to go to Göteborg and leave her in Västerås, and make her to say, “Papa, sini yuuk, Kayyisah kangen! (Papa, come here, I miss you!)”.

I praise and glorify the name of Allah, the Almighty, the Creator who creates all these nice people and these pleasant opportunities.

Ferry August Viawan

Göteborg, January 2008.

Table of Contents

Abstract.....	v
Acknowledgement	vii
Table of Contents	ix
1 Introduction.....	1
1.1 Background.....	1
1.2 Objectives.....	3
1.3 Contributions	4
1.4 Outline of the Thesis	4
1.5 List of Publications.....	5
2 Overview of Distributed Generation Technologies.....	9
2.1 Introduction	9
2.2 Internal Combustion Engines	10
2.3 Gas Turbines.....	10
2.4 Combined Cycle Gas Turbines.....	11
2.5 Microturbines	11
2.6 Fuel Cells.....	11
2.7 Solar Photovoltaic	12
2.8 Wind Power.....	12
2.9 Small Hydropower.....	13
2.10 Solar Thermal	14
2.11 Geothermal	14
2.12 Biomass	15
2.13 Tidal Power	15
2.14 Wave Power.....	16
3 Voltage and Reactive Power Control in Conventional Distribution Systems	17
3.1 Introduction	17
3.2 Voltage Drop in a Distribution System	18
3.3 Basic Voltage and Reactive Power Control	19
3.3.1 Voltage Control with On-Load Tap-Changer	20
3.3.2 Reactive Power Control with Switched Shunt Capacitors ..	23
3.4 Overview on Different Voltage and Reactive Power Control Methods	24
3.5 Proposed Local Voltage and Reactive Power Control	25
3.6 Case Study.....	28

3.6.1	Determination of OLTC and Capacitor Control Set Points	30
3.6.2	Simulation Results	33
3.7	Conclusions	38
4	Local Voltage and Reactive Power Control in the Presence of Distributed Generation	39
4.1	Introduction	39
4.2	DG Impact on Voltage Drop	41
4.3	Maximum DG allowed capacity	42
4.4	DG Impact on Voltage and Reactive Power Control	43
4.4.1	DG Operated at Varying Voltage	43
4.4.2	DG Operated at a Constant Voltage	45
4.5	Case Study	45
4.5.1	Determination of OLTC and Capacitor Control Set Points	47
4.5.2	Simulation Results	48
4.5.3	The Need of Control Set Points Readjustment	54
4.6	Conclusions	56
5	Coordinated Voltage and Reactive Power Control in the Presence of Distributed Generation	57
5.1	Introduction	57
5.2	Coordinated Voltage and Reactive Power Control in Transmission Systems	59
5.3	Brief Overview on Coordinated Voltage and Reactive Power Control in Distribution Systems	60
5.4	Proposed Coordinated Voltage and Reactive Power Control	61
5.4.1	Coordinated Voltage and Reactive Power Control without DG Involved	62
5.4.2	Coordinated Voltage and Reactive Power Control with DG Involved	66
5.5	Case Study with Induction Machine DG	67
5.5.1	Voltage Change due to Load Change, Capacitor Switching and OLTC Operation	70
5.5.2	Local Voltage and Reactive Power Control	71
5.5.3	Coordinated Voltage and Reactive Power Control	75
5.6	Case Study with Synchronous Machine DG	81
5.7	Conclusions	84
6	Voltage Stability in Conventional Distribution Systems	85
6.1	Introduction	85
6.2	Active and Reactive Power Transmission	86
6.2.1	Active and Reactive Power Transmission between Two Generators	87

6.2.2	Active and Reactive Power Transmission from Generator to Load	91
6.3	Voltage Stability	93
6.3.1	Definitions	93
6.3.2	Time Frames and Mechanisms of Voltage Stability	94
6.4	Voltage and Reactive Power Control in Distribution Systems with Voltage Stability Consideration.....	98
6.4.1	The Principle of STATCOM Operation.....	99
6.4.2	Coordination between STATCOM/SVC and OLTC	101
6.4.3	Modelling of STATCOM for Dynamic Simulation.....	102
6.5	Case Study	104
6.5.1	Transient Voltage Stability	106
6.5.2	Long-Term Large-Disturbance Voltage Stability	110
6.5.3	Long-Term Small-Disturbance Voltage Stability	113
6.6	Conclusions	115
7	Voltage Stability in the Presence of Distributed Generation	117
7.1	Introduction	117
7.2	Dynamic Characteristics of DG.....	118
7.2.1	Synchronous Machine DG	121
7.2.2	Induction Machine DG.....	123
7.3	Case Study	128
7.3.1	Cases with Synchronous Machine DG.....	129
7.3.2	Cases with Induction Machine DG	129
7.4	Simulation Results and Discussions	130
7.4.1	DG Impact on Transient Voltage Stability.....	131
7.4.2	DG Impact on Long-Term Large-Disturbance Voltage Stability	138
7.4.3	DG Impact on Long-Term Small-Disturbance Voltage Stability	144
7.5	Conclusions	146
8	Conclusions and Future Work.....	147
8.1	Conclusions	147
8.2	Future Work.....	149
	References	151
	Biography	157

Chapter 1

Introduction

This chapter is a general introduction to the work, voltage control and stability of power distribution systems in the presence of distributed generation (DG)^{)}. It starts with a brief overview of the increased interest in DG and possible DG impact on power distribution system operation and control. Potential problems related to the distribution system voltage control and voltage stability that may arise with the presence of DG is then explored further.*

1.1 Background

Electric power system development has been, for more than half a century, based on centralized large generating stations, with large generating units at a relatively small number of locations. In these stations, the voltage is stepped up to high voltage, extra high voltage, and ultra high voltage (HV, EHV and UHV) levels to be transmitted over long distances through interconnected transmission systems. The voltage from the HV transmission systems is then stepped down to radial medium voltage (MV) distribution systems and then to radial low voltage (LV) distribution systems, where the electric power is distributed to the loads [1].

Over the last few years, a number of influences have been combined to lead to the increased interest in the use of small-scale generation, connected to local distribution systems, which is commonly called ‘*Distributed Generation*’ (DG). Environmentally friendly electricity supply, electricity market liberalization, constraints on the construction of new transmission lines, increasing demand on highly reliable electricity supply, and reduction of

^{*)} DG will be used for “distributed generation” in general, covering a number of units, as well as for a single “distributed generator” and for a number of “distributed generators”.

the usage of fossil fuel resources, are some of benefits that DG can offer [2]-[5].

DG can come from renewable or non renewable energy resources, using both modern and conventional technologies. DG technologies include internal combustion engines, small gas turbines, wind turbines, small combined cycle gas turbines, microturbines, solar photovoltaic, fuel cells, biomass and small geothermal generating plants [6]-[8].

The structures of a traditional electric power system and a power system with distributed generation are shown in Figure 1.1. The presence of local generation in a distribution system will affect the distribution system. For example, the DG will alter the power flow in the distribution system, and the distribution system can no longer be considered as a system with unidirectional power flow. On the other hand, distribution systems have, for many years, been designed based on the assumption that the power flow is unidirectional [6], [9]-[11]. Hence, the presence of the DG, especially when the DG share is significant, will obviously impact the power distribution system operation and control. It is therefore deemed necessary to evaluate the impact of increased DG on the design requirements for distribution systems.

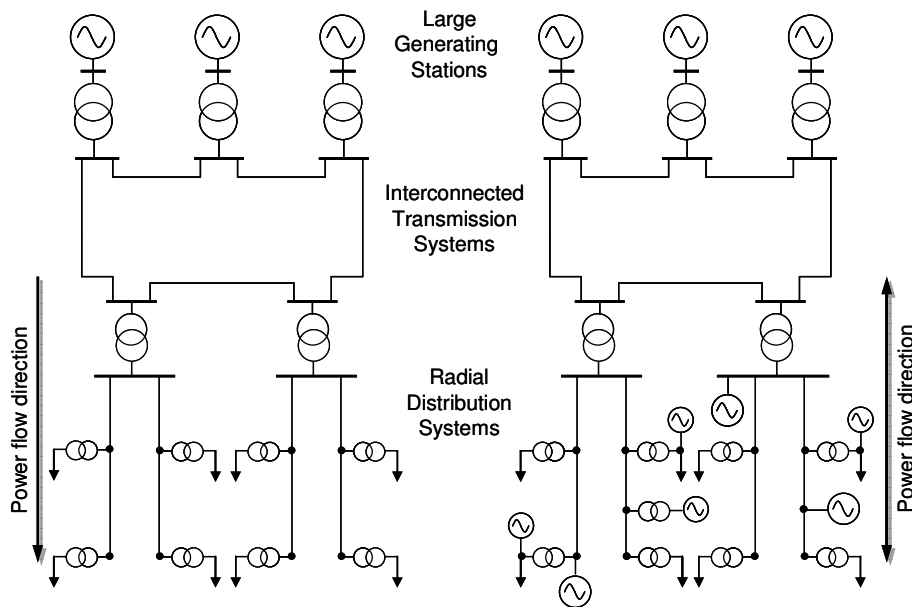

Figure 1.1. Traditional electric power system (left) and electric power system with distributed generations (right).

1.2 Objectives

The presence of DG will fundamentally impact the power system operation and control. Some of the impacts are on voltage control and voltage stability in the distribution systems.

Voltage control devices in *conventional distribution systems* (distribution systems without DG) are mostly operated based on the fact that the voltage decreases along the feeder, from the substation to the remote end. The presence of DG makes this characteristic no longer valid.

On-line tap-changers (OLTCs) in HV/MV or MV/LV transformers have been used to control the voltage at the secondary side of the transformer with power flowing from the primary to the secondary side of the transformer. High penetration of DG may cause the power to flow from the secondary to the primary side of the transformer.

The operation of the OLTC or other voltage control devices is affected by the change of power flow; the more the power flow changes, the more the OLTC operates. On the other hand, some DG technologies continuously generate varying power and the DG has not been designed to control voltage.

DG appear in different technologies with different steady state and dynamic characteristics. They may improve the distribution system voltage stability, but they can also cause the voltage stability in the distribution system to deteriorate.

These are just some of the problems that may arise with the presence of DG. Several questions then emerge: 1) How to coordinate DG with available voltage control devices in the distribution system in order to ensure that the distribution system will not lose the proper voltage regulation? 2) Will the power flow reversal due to the DG interfere with the effectiveness of the OLTC operation? 3) Will an OLTC operates excessively in the presence of DG with continuously varying output? 4) How to design the control strategy for an optimum voltage and reactive power control in the presence of DG? 5) How does DG impact voltage stability in the system? 6) How to mitigate the DG negative impact on voltage stability?

The questions mentioned require a thorough study. The main objective of this thesis is to address as much as possible of the problems and questions related to voltage control and voltage stability in distribution systems, in the presence of a large integration of synchronous and induction machines DG.

1.3 Contributions

In the opinion of the author, the main contribution of the voltage control part of the thesis is on the design of different control strategies for the voltage and reactive power control in the presence of synchronous and induction machines DG, for various possible operation characteristics of the DG. This contribution is presented in papers III, VII, VIII and XIII (the list of publications is shown in the last section of this chapter).

The method in paper VII is related to current practice of the distribution system voltage and reactive power control. According to the comment of the Chief Editor of *IEEE Transactions on Power Delivery*, paper VII would be of interest to the practicing engineer. On the other hand, papers VIII and XIII are related to the modernization of the distribution system voltage and reactive power control. According to the comments of some reviewers for paper VIII, the paper calls attention to the important modifications related to modern distribution systems, though the contribution of the paper is considerably incremental. One of the reviewers also considers that the paper will be useful for distribution engineers.

Further, the author considers that the main contribution of the voltage stability part of the thesis is on the design of the DG operation mode in order to give favorable impact on voltage stability. The favorable impact means that the DG will minimize the decrease of the voltage stability when the DG has a negative impact and will maximize the increase of the voltage stability when the DG has a positive impact on the voltage stability. This contribution is presented in paper XI.

1.4 Outline of the Thesis

Chapter 1 is the introduction to the thesis.

Chapter 2 gives an overview of different DG technologies. DG potentials, challenges, sizes and power output characteristics are addressed.

Chapter 3 discusses voltage and reactive power control in conventional distribution systems. Literature reviews on different voltage and reactive power control methods are presented. Local voltage and reactive power control based on coordination among OLTC, substation capacitors and feeder capacitors without communication among them, with loss minimization as the objective, are investigated in further detail.

Chapter 4 presents the analysis on how the local voltage and reactive power control in Chapter 3 in the presence of DG will be. It starts with a basic overview on the possible impact of different DG technologies on distribution system voltage control. The impact of DG, with dispatchable power output and with controllable voltage and reactive power, on the local voltage and reactive control is then examined. Comparative analysis between different possible operations of the DG is presented.

Chapter 5 illustrates coordinated voltage and reactive power control in the distribution system in the presence of DG. Both cases, without and with DG involved in the voltage control are treated. The case of DG with varying power output and uncontrollable reactive power is also included. A short term operation planning based on on-line measurement, communication, optimization, and load and DG forecasting is developed for the coordinated voltage and reactive power control.

Chapter 6 deals with voltage stability in conventional distribution systems and the role of different reactive power control compensation devices in distribution systems on improving voltage stability. Reactive power transmission, the importance of providing reactive power locally and different voltage instability mechanisms are briefly presented. A case study is then presented to illustrate some of the important properties of the voltage stability concepts.

Chapter 7 investigates voltage stability in distribution systems in the presence of DG. The dynamic performance of different generator technologies for DG is briefly described. A case study is then presented to evaluate the impact of different DG generator technologies and different DG operations, as well as the role reactive power compensation devices; on different voltage stability mechanisms.

Chapter 8 presents conclusions and recommendations for future works.

1.5 List of Publications

This doctoral thesis is a continuation and extension of the licentiate thesis

[A] F.A. Viawan, “Steady State Operation and Control of Power Distribution Systems in the Presence of Distributed Generation”, Chalmers University of Technology, 2006.

The work presented in the present thesis has been published in the publications listed below. The first six publications have been discussed in the licentiate thesis. The ones started with *) are international journal papers.

- [I] F.A. Viawan and A. Sannino, “Analysis of Voltage Profile on LV Distribution Feeders with DG and Maximization of DG Integration Limit”, in *Proceedings of 2005 CIGRE Symposium on Power Systems with Dispersed Generation*, Athens.
- [II] F.A. Viawan and A. Sannino, “Voltage Control in LV Feeder with Distributed Generation and Its Impact to the Losses”, in *Proceedings of 2005 IEEE Power Tech Conference*, St. Petersburg.
- [III] *) F.A. Viawan, A. Sannino and J.E. Daalder, “Voltage Control with On-Load Tap Changer in MV Feeder in Presence of Distributed Generation”, *Electric Power System Research*, vol. 77, issue 10, August 2007.
- [IV] F.A. Viawan, F. Vuinovich and A. Sannino, “Probabilistic Approach to the Design of Photovoltaic Distributed Generation in Low Voltage Feeder”, in *Proceedings of 2006 International Conference on Probabilistic Methods Applied to Power Systems*, Stockholm.
- [V] F.A. Viawan and M. Reza, “The Impact of Synchronous Distributed Generation on Voltage Dip and Overcurrent Protection Coordination”, in *Proceedings of 2005 International Conference on Future Power Systems*, Amsterdam.
- [VI] F.A. Viawan, D. Karlsson, A. Sannino and J. Daalder, “Adaptive Protection Scheme for Meshed Distribution Network with High Penetration of Distributed Generation”, in *Proceedings of 2006 Power System Conference on Advanced Metering, Protection, Control and Distributed Resources*, South Carolina.
- [VII] *) F.A. Viawan and D. Karlsson, “Voltage and Reactive Power Control in Systems with Synchronous Machine Based Distributed Generation”, accepted for publication in *IEEE Transaction on Power Delivery*.
- [VIII] *) F.A. Viawan and D. Karlsson, “Combined Local and Remote Voltage and Reactive Power Control in the Presence of Induction Machine Based Distributed Generation”, *IEEE Transaction on Power Systems*, vol. 22, no. 4, November 2007.
- [IX] F.A. Viawan and D. Karlsson, “Voltage and Reactive Power Control in Closed Loop Feeders with the Presence of Distributed Generation”, in *Proceedings of 2007 IEEE PowerTech Conference*, Lausanne.
- [X] F.A. Viawan and D. Karlsson, “Protection Schemes in Closed Loop Feeders with the Presence of Synchronous Machine Based Distributed Generation”, in *Proceedings of 2007 IEEE PowerTech Conference*, Switzerland.

-
- [XI] *) F.A. Viawan and D. Karlsson, “Voltage Control with Distributed Generation Systems for Voltage Stability Enhancement”, submitted to *IEEE Transaction on Power Delivery* (in review).
 - [XII] F.A. Viawan and D. Karlsson, “Voltage Control and Voltage Stability with Closed Loop Feeders and Distributed Generation”, accepted in *2008 IASTED Power and Energy System Conference*.
 - [XIII] F.A. Viawan and D. Karlsson, “Coordinated Voltage and Reactive Power Control in the Presence of Distributed Generation”, submitted to *2008 IEEE PES General Meeting*.

The author has also contributed to the following publications:

- [XIV] *) M. Reza, J. Morren, F. A. Viawan and W. L. Kling,” The impact of the protection scheme of converter connected distributed generation on power system transient stability”, *International Journal of Energy Technology and Policy*, vol. 5, no.5, pp. 550 – 568, 2007.
- [XV] *) M. Reza, A.O. Dominguez, P.H. Schavemaker, A. Asmara, F. A. Viawan and W. L. Kling,” Controlling the power balance in an ‘empty network’ ”, *International Journal of Energy Technology and Policy*, vol. 5, no.5, pp. 584 – 602, 2007.

Chapter 2

Overview of Distributed Generation Technologies

This chapter presents an overview of different distributed generation (DG) technologies based on the primary energy source. The points that will be addressed are DG potentials, challenges, sizes and power output characteristics.

2.1 Introduction

There are many DG technologies available. DG can be based on various primary energy sources. The type of the primary energy source will, to a large extent, determine the type of grid connection applied and the output characteristic of the DG.

Based on the output power characteristic, DG can be classified as dispatchable or non-dispatchable. When the DG is dispatchable, the DG operator can determine a power output of the DG units by controlling the primary energy sources that are supplied to the DG units. When the DG is non-dispatchable, the operator cannot dispatch the DG units because the behavior of the primary energy sources cannot be controlled. Non-dispatchable units are normally the ones driven by renewable energy sources, where the power output will depend on the availability of the energy sources.

DG can be connected to the grid directly using synchronous or induction generators or via a power electronic interface [12]-[14]. Synchronous generator units are typically utilized for DG with internal combustion engines, gas turbines and combined cycle gas turbines, solar thermal, biomass and geothermal. DG with induction generators are extensively used in wind power and small hydropower plants. DG interfaced with power electronic converters are used in solar photovoltaic generation, fuel cells, microturbines, and also wind power. DG with a synchronous generator or a power electronic interface

have the advantage that they can be controlled to provide or absorb reactive power.

Different DG technologies based on various primary energy sources will be discussed briefly hereafter. As explained in Section 1.1, DG is a small-scale generation connected to local distribution systems. Hence, when the size of the generation technology explained hereafter becomes large and the generation can no longer be connected to the distribution system, the generation is no longer considered as DG.

2.2 Internal Combustion Engines

Reciprocating internal combustion engines (ICEs) convert heat from combustion of a fuel into rotary motion which, in turn, drives a generator.

ICEs are one of the most common technologies used for DG. They represent a proven technology with low capital cost; large size range, from a few kW to MW; good efficiency; possible thermal or electrical cogeneration in buildings and good operating reliability. These characteristics, combined with the engines' ability to start up fast during a power outage and not requiring much space for installation, make them the main choice for emergency or standby power supplies.

The key barriers to ICE usage are: high maintenance and fuel cost, which is the highest among the DG technologies; high NO_x emissions, which are also highest among the DG technologies and a high noise level [6]-[7].

2.3 Gas Turbines

Gas turbines consist of a compressor, combustor, and turbine-generator assembly that converts the rotational energy into electric power output.

Gas turbines of all sizes are now widely used in the power industry. Small industrial gas turbines of 1 – 20 MW are commonly used in combined heat and power (CHP) applications. They are particularly useful when higher temperature steam is required (higher than the steam produced by a reciprocating engine). The maintenance cost is slightly lower than for reciprocating engines. Gas turbines can be noisy. Emissions are somewhat lower than for combustion engines, and cost-effective NO_x emission-control technology is commercially available [7].

2.4 Combined Cycle Gas Turbines

In a combined cycle gas turbine (CCGT), the exhaust air-fuel mixture exchanges energy with water in the boiler to produce steam for the steam turbine. The steam enters the steam turbine and expands to produce shaft work, which is converted into additional electric energy in the generator. Finally, the outlet flow from the turbine is condensed and returned to the boiler.

The CCGT is becoming increasingly popular due to its high efficiency. However, GT installations below 10 MW are generally not combined-cycle, due to the scaling inefficiencies of the steam turbine [7].

2.5 Microturbines

Microturbines extend gas turbine technology to smaller scales. The technology was originally developed for transportation applications, but is now finding a niche in power generation. One of the most striking technical characteristics of microturbines is their extremely high rotational speed, up to 120,000 rpm.

Microturbines produce high frequency ac power. A power electronic inverter converts this high frequency power into a usable form. Individual unit of microturbines ranges from 30 - 200 kW, but it can be combined readily into systems of multiple units. Low combustion temperatures can assure very low NO_x emission levels. They make much less noise than a turbine of comparable size [7].

Most microturbines use natural gas. The use of renewable energy sources, such as ethanol, is also possible [15]. The main disadvantages of microturbines at the moment are their short track record and high costs compared with gas combustion engines.

2.6 Fuel Cells

Fuel cells are electro chemical devices that convert the chemical energy of a fuel directly to usable energy — electricity and heat — without combustion. This is quite different from most electric generating devices (e.g., steam turbines, gas turbines, and combustion engines) which first convert the

chemical energy of a fuel to thermal energy, then to mechanical energy, and, finally, to electricity.

Fuel cells produce electricity with high efficiencies, up to 40 to 60%, with negligible harmful emissions, and operate so quietly that they can be used in residential neighborhoods. These are the main advantages of fuel cells, besides their scalability and modularity. The main challenge of the commercialization of fuel cells is the high investment cost [6].

2.7 Solar Photovoltaic

Photovoltaic (PV) systems involve the direct conversion of sunlight into electricity without any heat engine. PV systems have been used as the power source for very small applications like calculators and watches, for water pumping, remote buildings, communications, satellites and space vehicles, as well as for megawatt-scale power plants.

Though a PV device has a very low operating cost, it is capital intensive and exhibits a low efficiency, which makes the PV systems expensive. Without subsidies, PV power remains two to five times as expensive as grid power, where grid power exists. However, where there is no grid, PV power can be the cheapest electricity source. PV systems can also be competitive during peak demand periods.

The PV implementation is encouraged by the almost unlimited availability of sunlight, long life cycle, high modularity and mobility, easy maintainability (since there are no moving parts), very low operation cost, environmental friendly, ability for off-grid application and short time for design, installation and start up. Mostly, individual PV modules range from 20 W to 100 kW. Several barriers for PV systems include significant area requirements due to the diffuse nature of the solar resource, higher installation cost than other DG technologies, and intermittent output with a low load factor [6]-[7] and [16].

2.8 Wind Power

Wind energy plays a key role in generating electricity from renewable energy resources. Until 2006, more than 48,500 MW wind power capacity had been installed in Europe [18]. Germany, Spain and Denmark are the leading countries in wind power, and they account for 78% of the total wind power

capacity in Europe. Both off-shore and on-shore wind power implementations are increasing rapidly.

Today, large wind power plants are competing with fossil-fuelled power plants in supplying economical clean power in many parts of the world [16]. In this sense, wind power is more like central generation than DG. The size of commercial wind turbines has increased significantly from 50 kW in early 1980s to be up to 4.5 MW recently [19]. This increase obviously creates an economic of scale for the wind power technology.

The main challenges of the wind power technology are intermittency and grid reliability [20]. Since wind power generation is based on natural forces, it cannot dispatch power on demand. On the other hand, utilities must supply power in close balance to demand. Thus, as the share of wind energy increases, integration of wind turbines into the electric network will need more attention. Another barrier is transmission availability. This is because, sometimes, the best locations for wind farms are in remote areas without close access to a suitable transmission line.

2.9 Small Hydropower

Hydropower turbines were first used to generate electricity for large scale use in the 1880s. Expansion and increasing access to transmission networks has led to concentrating power generation in large units benefiting from economic of scale. This resulted in a trend of building large hydropower installations rather than small hydropower systems for several decades. However, liberalization of the electricity industry has contributed in some areas to the development of small hydropower generating capacity by independent power producers [17].

Small hydropower (SHP) is commonly used to refer to hydropower with capacity less than 10 MW. Other terms that are normally used are mini hydropower for SHP with capacity between 100 kW and 1 MW and micro hydropower for SHP with capacity below 100 kW [20].

The power generated from SHP plants is quite large. The European Small Hydropower Association reported that up to 2006, the total installed capacity of SHP in Europe is 13,000 MW [21].

2.10 Solar Thermal

Solar thermal systems generate electricity by concentrating the incoming sunlight and then trapping its heat, which can raise the temperature of a working fluid to a very high degree to produce steam and then generate electricity. Notice that this process is different from that of a photovoltaic panel where the sunlight is directly converted into electricity without the intermediate heat collection [22]. Compared to solar photovoltaic, the solar thermal is more economical, as it eliminates the costly semiconductor cells [16].

Applications of concentrating solar power are now feasible from a few kilowatts to hundreds of megawatts. Solar-thermal plants can be grid-connected or stand-alone applications, for central generation or DG applications. They are suitable for fossil-hybrid operation or can include cost-effective thermal storage to meet dispatch requirements [17].

One such commercial solar thermal power plants is rated 350 MW, located in California Mojave Desert and connected to the Southern California Edison's transmission grid. This capacity is more than 90% of the world's solar thermal capacity up to 1999 [16].

2.11 Geothermal

Geothermal energy is available as heat emitted from within the earth, usually in the form of hot water or steam. While this is an abundant source, only a very small fraction can be converted commercially to electricity with today's technology. As of 1999, the electricity generating capacity from geothermal sources worldwide was around 8,000 MW. The United States and the Philippines account for 50% of the capacity installed worldwide [22].

Geothermal power plants are highly capital intensive with low operating costs. The plants are also clean without CO₂ emission during operation. A new and significant opportunity for geothermal development is emerging when the reduction of carbon emission, as a response to greenhouse gas emission concerns, is considered as a credit [22].

2.12 Biomass

Biomass resources include agricultural waste, animal manure, forest waste, industry waste, municipal waste, sewage sludge, crops, etc. Biomass can be converted into electricity (or heat) in one of several processes. The majority of biomass electricity is generated using a steam cycle where biomass material is first converted into steam in a boiler. The resulting steam is then used to turn a turbine generator. Biomass can also be used with coal to produce electricity in an existing power plant (co-firing). Co-firing is the most economical near-term option for introducing new biomass electricity generation and lowers the air emissions from coal-fired power plants. Another alternative is to convert the solid biomass into a fuel gas. The fuel gas can then be used in a piston-driven engine, high efficiency gas turbine generator, or a fuel cell [22].

Biomass use for power and CHP generation is steadily expanding in Europe, mainly in Austria, Germany, the United Kingdom, Denmark, Finland and Sweden. Global biomass power capacity up to 2005 is around 44,000 MW [23].

Main barriers to widespread use of biomass for power generation are cost, low conversion efficiency and feedstock availability. Biomass has a low energy density, which makes transportation over long distance costly. Over exploitation of biomass sources should be avoided. Certifications that biomass feedstock is produced in a sustainable way are needed to improve the acceptance of public forest and land management [23].

2.13 Tidal Power

Tidal energy is derived from the gravitational forces of attraction between the earth and the moon, and the earth and the sun. A long dam, called a “barrage” is built across a river estuary. When the tide goes in and out, the water flows through tunnels in the dam. Ebb and flow can be used to turn a turbine. When the tides come, they are trapped in reservoirs behind dams, and later, when the tides drop, the dam water can be used like in regular operation of hydroelectric power plants. There are only a few sites in the world that have been identified as possible commercial tidal power stations. The largest facility is the 240 MW La Rance Station in France [24].

Like other renewable energy sources, tidal energy is clean and free of greenhouse gases. Maintenance and operating costs are not high. However,

building a barrage along estuary for a tidal generating station is expensive and affects a very wide area.

2.14 Wave Power

The energy in waves comes from the movement of the ocean water and the changing height and speed of the swells.

The world has an abundant source of wave energy. For example, it is estimated that commercially realizable wave power generation capacity in Scotland is 14,000 MW. Wave energy is also considered as one of the most highly concentrated of the renewable energies. Further, compared to other renewables, wave energy is also relatively predictable. Wave energy is also well suited to electrify remote communities. However, compared to other renewables, wave energy has not achieved commercialized acceptance yet [25].

Until recently, most wave power plant projects were in the research stage, though a substantial number of plants have been deployed in the sea as demonstration schemes. The dominating countries in the development of wave power have so far been Denmark, India, Ireland, Japan, Norway, Portugal, the Netherlands, the U.K. and the U.S. [26].

In Sweden, a full scale wave power plant facility, for research purpose, is being built on the west coast. The research facility is scheduled to be completed by 2008 and will be in operation until 2013-2014 [27].

Chapter 3

Voltage and Reactive Power Control in Conventional Distribution Systems

This chapter discusses voltage and reactive power control in conventional distribution systems (distribution systems without distributed generation). It starts with voltage characteristics in the conventional distribution system and how the voltage and reactive power control equipment operate. Different voltage and reactive power control methods are briefly explained. Voltage and reactive power control based on local operation of the voltage and reactive power control equipment are investigated in further detail. Results related to this chapter are published in Paper III and Paper VII.

3.1 Introduction

The basic function of voltage regulation in the distribution system operation is to keep the steady state voltage in the system stable within an acceptable range all the time. The desired voltages can be obtained by either directly controlling the voltage or by controlling the reactive power flow that in turn will affect the voltage drop. The equipment normally used for the voltage and reactive power control are on-load tap-changer (OLTC) transformers, switched shunt capacitors and steps voltage regulator [10]-[11]. Such equipment are mostly operated based on an assumption that the power flows in one direction only and the voltage decreases along the feeder, from the substation to the remote end.

An OLTC transformer is a transformer with automatically adjustable taps. The OLTC is a part of most of HV/MV substation transformers. A shunt capacitor generates reactive power to compensate the reactive power demand and thereby boosts the voltage. Shunt capacitors can be installed in the substation (which will here be called *substation capacitors*) or along the feeder (which will here be called *feeder capacitors*). A steps voltage regulator

is an autotransformer with automatically adjustable taps, which is usually installed when the feeder is too long in such a way that voltage regulation with OLTC and shunt capacitors is not sufficient.

Voltage and reactive power control involves proper coordination among the available voltage and reactive power control equipment. Many distribution network operators (DNOs) operate such equipment locally by using conventional controllers to maintain the voltages in the distribution system within the acceptable range and to minimize power losses. Different methods have been proposed to improve the voltage and reactive power control in the distribution system, both in the planning and in the operation stage.

Most recently, many researchers have addressed the problem of voltage and reactive power control in distribution systems by focusing on automated distribution system, with off-line setting control or real time control. The off-line setting control aims to find a dispatch schedule for capacitor switching and OLTC movement based on a one day to several hours ahead load forecast, meanwhile the real time control aims to control the capacitor and OLTC based on real time measurements and experiences. The main obstacle application of the off-line setting control method is its dependency on communication links and remote control to all capacitors. However, many DNOs do not have communication links downstream to the feeder capacitor locations. The real time control requires an even higher level of distribution system automation.

The voltage and reactive power control proposed in this chapter is adopted from the local voltage and reactive power control using conventional controllers. The loss minimization is set as the objective function, meanwhile the allowed voltage range, transformer capacity and conductor current capacity are considered as the operating constraints. Further, OLTC operation and voltage fluctuation index are also investigated. The method is tested in a case study. The results are compared with local voltage and reactive power control where the feeder capacitors are time controlled, which is still widely used.

3.2 Voltage Drop in a Distribution System

A basic overview on voltage drop in a distribution system is shown in a one line diagram in Figure 3.1. The current \underline{I} as a function of the load complex apparent power $\underline{S} = P_L + jQ_L$ and the load voltage \underline{U}_2 will be

$$\underline{I} = \frac{\underline{S}^*}{\underline{U}_2^*} = \frac{P_L - jQ_L}{\underline{U}_2^*} \quad (3-1)$$

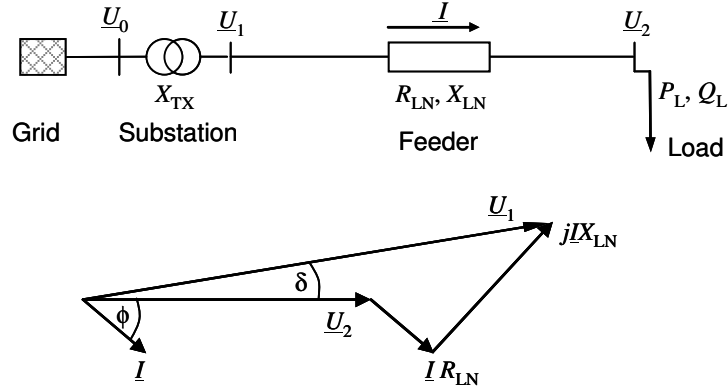

Figure 3.1. One line diagram and corresponding phasor diagram for an illustration of the voltage drop in a distribution system.

The voltage drop on the feeder is given by

$$\begin{aligned}
 |U_1 - U_2| &= |I(R_{LN} + jX_{LN})| \\
 &= \left| \frac{(R_{LN}P_L + X_{LN}Q_L) - j(X_{LN}P_L - R_{LN}Q_L)}{U_2} \right| \quad (3-2)
 \end{aligned}$$

For a small power flow, the voltage angle δ between U_2 and U_1 in (3-2) is small, and the voltage drop $\Delta U = |U_1 - U_2|$ can be approximated by

$$\Delta U \approx \frac{R_{LN}P_L + X_{LN}Q_L}{U_2} \quad (3-3)$$

3.3 Basic Voltage and Reactive Power Control

It can be concluded from Equations (3-2) - (3-3) that the load always causes a voltage drop and the voltage profile in conventional distribution systems (with only load) is decreasing towards the end. This voltage drop and voltage profile is the basis for voltage regulation in distribution systems. The transformer secondary voltage can be adjusted by changing the voltage ratio of the transformer, meanwhile the voltage drop on the feeder can be reduced

by compensating the reactive power demand using shunt capacitors; which will be explained hereafter.

3.3.1 Voltage Control with On-Load Tap-Changer

The ratio of a transformer can be changed by adding turns to or subtracting turns from either the primary or the secondary winding using a load tap-changer (LTC). The LTC can be located at the primary or the secondary side of the transformer.

The representation of a transformer equipped with an LTC and its equivalent diagram is shown in Figure 3.2. Notation I , U , n and y in the figure indicates current, voltage, normalization of the transformer turn ratio and transformer admittance, respectively; and subscripts p and s indicate primary and secondary sides of the transformer, respectively.

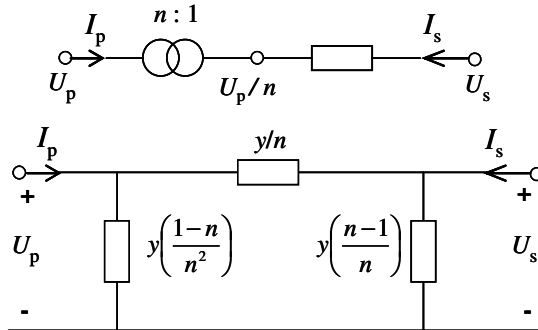

Figure 3.2. LTC representation and its equivalent diagram.

There are two types of LTC, no-load tap-changer where the transformer ratio can be changed only when the transformer is de-energized, and on-load tap-changer (OLTC) where changing of the tap position is possible also when the power transformer is carrying load. This thesis will only deal with OLTC that has been widely used in voltage regulation for many decades.

The OLTC basic arrangement is shown in Figure 3.3. The OLTC controller keeps the substation secondary bus voltage U_1 constant within the range

$$U_{LB} \leq U_1 \leq U_{UB} \quad (3-4)$$

where

$$U_{LB} = U_{set} - 0.5U_{DB} \text{ is the lower boundary voltage}$$

$$U_{UB} = U_{set} + 0.5U_{DB} \text{ is the upper boundary voltage}$$

U_{set} is the set point voltage
 U_{DB} is the deadband.

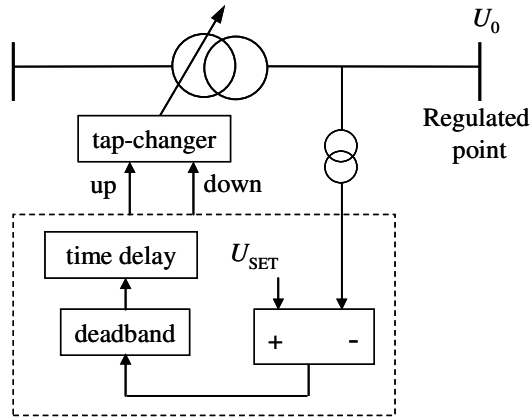

Figure 3.3. Basic OLTC arrangement.

An OLTC is normally provided with a line drop compensation (LDC) function in order to keep the voltage at a remote bus constant without using any communication link. The OLTC arrangement with LDC activated is shown in Figure 3.4. The LDC estimates the line voltage drop based on the line current I , line resistance R_{LN} and line reactance X_{LN} , and performs voltage corrections to get U_{LC} – the voltage at a certain point that is considered as the load center (LC) – constant within the range

$$U_{\text{LB}} \leq U_{\text{LC}} \leq U_{\text{UB}} \quad (3-5)$$

Properly adjusting R_{LN} and X_{LN} to the turns ratios of the current transformer (CT) and the potential transformer (PT) yields

$$R_{\text{set}} = \frac{N_{\text{CT}}}{N_{\text{PT}}} R_{\text{LN}} \quad (3-6)$$

$$X_{\text{set}} = \frac{N_{\text{CT}}}{N_{\text{PT}}} X_{\text{LN}} \quad (3-7)$$

where

R_{set} and X_{set} are LDC settings for the resistive/reactive compensation

N_{CT} is the turns ratio of the CT

N_{PT} is the turns ratio of the PT.

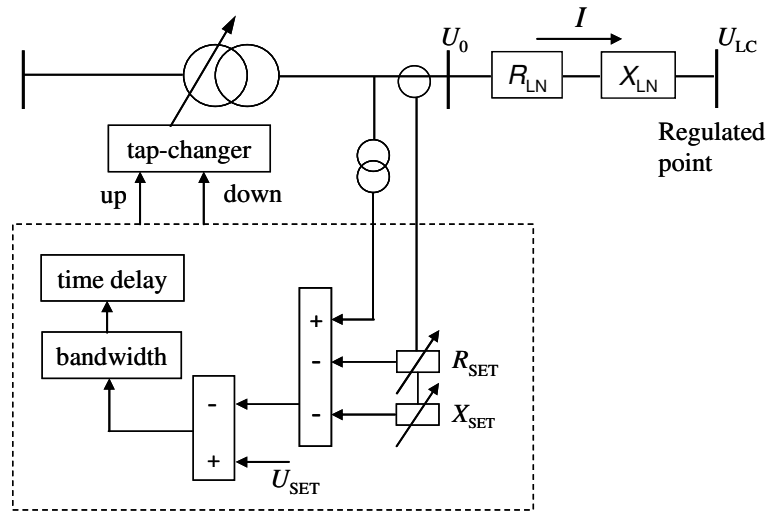

Figure 3.4. OLTC arrangement with LDC function activated.

The voltage at the LC during minimum and maximum load is approximated as

$$U_{LC} = U_{0,\max} - I_{\max} (R_{LN} \cos\phi + X_{LN} \sin\phi) \quad (3-8)$$

$$U_{LC} = U_{0,\min} - I_{\min} (R_{LN} \cos\phi + X_{LN} \sin\phi)$$

where

$U_{0,\max}$ and $U_{0,\min}$ are maximum and minimum sending-end voltage

I_{\max} and I_{\min} are maximum and minimum line current

$\cos\phi$ is the pf at the OLTC location.

In practice, many OLTCs are operated with the LDC function disabled, which results in a simpler control and prevents unnecessary error. The reason is that the LDC employs load parameters in its control, as shown by Equation (3-8). The changes in the pf or active and reactive power flow between the OLTC and the LC will affect the performance of the LDC performance [10]. This performance will be deteriorated if the X/R ratio of the setting is not properly adjusted [28]. From this point forward, this thesis will only discuss OLTC with the LDC disabled. OLTC with the LDC activated has been discussed in Chapter 5 of the licentiate thesis described in Section 1.5.

3.3.2 Reactive Power Control with Switched Shunt Capacitors

Shunt capacitors inject reactive power to the system according to

$$Q_C = Q_{C,\text{rat}} U_C^2 \quad (3-9)$$

where

Q_C is the reactive power injected by the capacitor in Mvar

$Q_{C,\text{rat}}$ is the Mvar rating of the capacitor

U_C is the voltage in pu (relative to the capacitor voltage rating).

The reactive power injected by the capacitor will compensate the reactive power demand and thereby boost the voltage. For example, consider that in Figure 3.1, a shunt capacitor injecting reactive power Q_C is connected to the load bus. The voltage drop on the feeder can then be approximated as

$$\Delta U \approx \frac{R_{\text{LN}} P_L + X_{\text{LN}} (Q_L - Q_C)}{U_2} \quad (3-10)$$

which indicates that the capacitor reduces the voltage drop. Further, when the capacitor properly compensates the reactive power demand, the capacitor will decrease the feeder current. This will in turn decrease the feeder losses P_{Loss} , according to the following equations:

$$I = \frac{\sqrt{P_L^2 + (Q_L - Q_C)^2}}{U_2} \quad (3-11)$$

$$P_{\text{Loss}} = I^2 R_{\text{LN}} \quad (3-12)$$

In order to properly compensate the reactive power demand that changes from minimum to maximum, the shunt capacitor may need to be switched on at the load maximum and to be switched off at the load minimum. When the load varies during the day, the switched capacitors should be properly controlled. Different conventional controls can be used to control switched capacitors, such as time, voltage and reactive power. Time controlled capacitors are especially applicable on feeders with typical daily load profiles in a long term, where the time of the switching-on and off of the shunt capacitor can be predicted. The main disadvantage of this control is that the control has no flexibility to respond to load fluctuation caused by weather, holidays, etc. Voltage controlled capacitors are most appropriate when the primary role of the capacitor is for voltage support and regulation. Reactive power controlled capacitors are effective when the capacitor is intended to minimize the reactive power flow [10].

3.4 Overview on Different Voltage and Reactive Power Control Methods

Voltage and reactive power control involves proper coordination among the voltage and reactive power control equipment in the distribution system to obtain an optimum voltage profile and optimum reactive power flows in the system according to the objective function and operating constraints.

Many DNOs operate OLTC and shunt capacitors locally by using conventional controllers, e.g., voltage controller for the OLTC and either voltage, reactive power or time controllers for the capacitors; to perform basic voltage and reactive power control functions, e.g., to maintain the voltages in the distribution system within the acceptable range and to minimize power losses.

Different voltage and reactive power control methods have been proposed. Properly locating and sizing shunt capacitors will decrease power losses. As an improvement to the capacitor planning based on the load size, methods to include customer load profiles and characteristics in the capacitor planning are proposed in [30]-[32]. Proper capacitor planning will also improve the voltage profile in the distribution system. The capacitor locating and sizing is studied and executed in the planning stage of the distribution system. In order to enhance the distribution system further, the capacitor should also be switched properly in the operation stage of the distribution system [31], using different types of available capacitor control.

Most recently, many researchers have addressed the problem of voltage and reactive power control in distribution systems by focusing on automated distribution systems, such as in [33]-[37]. At the moment, the voltage and reactive power control based on automated distribution systems can be divided into two categories: off-line setting control and real time control [36]. The off-line setting control, [36]-[37] for instance, aims to find a dispatch schedule for the capacitor switching and the OLTC movement based on a one-day-ahead load forecast. Meanwhile, the real time control, [33]-[35] for instance, aims to control the capacitor and OLTC based on real time measurements and experiences.

The application of dispatch schedule based load forecasting is motivated by the fact that although there is a random fluctuation in the load variation, the major component of the load variations is related to weather conditions. Furthermore, there is a deterministic load pattern during the day due to social activities [38]. Therefore, the load profile is quite predictable. It can be forecasted one-day-ahead with an average error less than 2% [38]-[39].

Different objective functions and operating constraints have been proposed in voltage and reactive power control with automated distribution

systems. Nevertheless, all researchers [33]-[37] still consider loss minimization and keeping the voltage within the acceptable range as the main objective and constraint in the voltage and reactive power control. Another objective that is commonly proposed is flattening the voltage profile [35], [37]. Commonly added operating constraints include the maximum number of OLTC operations and capacitor switchings [34], [36]-[37], and the minimum distribution system pf [34]. Other references, such as [35], consider minimization of OLTC operations and capacitor switchings as the objective function.

The automated control with off-line setting proposed in [36]-[37] fully replaces the local control operation of the conventional OLTC and capacitor operations with a remotely controlled operation. The main obstacle application of this method is its dependency on communication links and remote control to all capacitors. However, many DNOs do not have communication links downstream to the feeder capacitor locations.

3.5 Proposed Local Voltage and Reactive Power Control

As has been explained in the previous section, voltage and reactive power control in distribution systems without using communication links are still common practice in the distribution system operation. This voltage and reactive power control method is investigated further in this section. The voltage and reactive power control equipment considered here are OLTC and shunt capacitors. Steps voltage regulators are not considered as it is assumed that the feeders are not excessively long. This means that OLTC and capacitors are considered sufficient to keep the voltage at all buses within the allowed range.

The voltage and reactive power control equipment are operated locally by using conventional controllers. The set points of the controllers are searched in such a way that, on a daily basis, the total losses can be minimized. By having proper coordination among the equipment involved in the voltage and reactive power control, the number of OLTC operations and the voltage fluctuations in the system will also be decreased, though these indices are not included in the optimization process.

The losses considered here are the losses in the distribution system plus the transformer. The operating constraints are the maximum allowed voltage variations, line thermal capacity and transformer capacity.

Mathematically, the objective function can be expressed as

$$J = \text{Min} \left(\sum_{i=1}^N P_{\text{Loss},i} \right) \quad (3-13)$$

subject to

$$U_{\min} \leq U_{k,i} \leq U_{\max}, \forall \text{ buses} \quad (3-14)$$

$$I_{L,p,i} \leq I_{L,p,\text{rat}}, \forall \text{ lines} \quad (3-15)$$

$$S_{TX,i} \leq S_{TX,\text{rat}} \quad (3-16)$$

where

$P_{\text{Loss},i}$ = total system losses at time i

$U_{k,i}$ = voltage at bus- k at time i

N = number of time intervals in a day, which makes $N = 144$ for a 10 minutes sampling interval

U_{\min} = minimum allowed voltage, i.e., 0.94 pu

U_{\max} = maximum allowed voltage, i.e., 1.05 pu

$I_{L,p,i}$ = current flowing on line- p at time i

$I_{L,p,\text{rat}}$ = line thermal capacity of line- p

$S_{TX,i}$ = apparent power flow on substation transformer at time i

$S_{TX,\text{rat}}$ = substation transformer rating.

The daily number of OLTC operations and the voltage fluctuations are mathematically expressed as

$$DT = \sum_{i=1}^N |TAP_i - TAP_{i-1}| \quad (3-17)$$

$$UF_k = \frac{1}{N} \left(\sum_{i=1}^N |U_{k,i} - U_{k,i-1}| \right) \times 100\%, \forall \text{ buses} \quad (3-18)$$

where

TAP_i = OLTC tap position at time i

DT = daily number of OLTC operations

UF_k = the average of steady state voltage fluctuation at bus- k .

Both substation capacitors and feeder capacitors are treated. Substation capacitors are intended to compensate the reactive power flow through the substation transformer. With the coordination of the substation capacitors and the OLTC, the substation secondary bus voltage is regulated by the OLTC and the substation primary bus voltage is maintained by the substation capacitors, as also suggested in [40]. The feeder capacitors will maintain the voltages on the feeder, as a supplement to the voltage regulation by the OLTC, and compensate reactive power on the feeder.

The main role of the substation capacitors and feeder capacitors is to minimize the reactive power flow through the transformer and to provide voltage support to the feeder, respectively. Hence, the substation capacitors will be controlled from the reactive power flow (on the transformer) and the feeder capacitors will be controlled from the voltage (at the capacitor connection point). Figure 3.5 shows the conceptual diagram of this coordination.

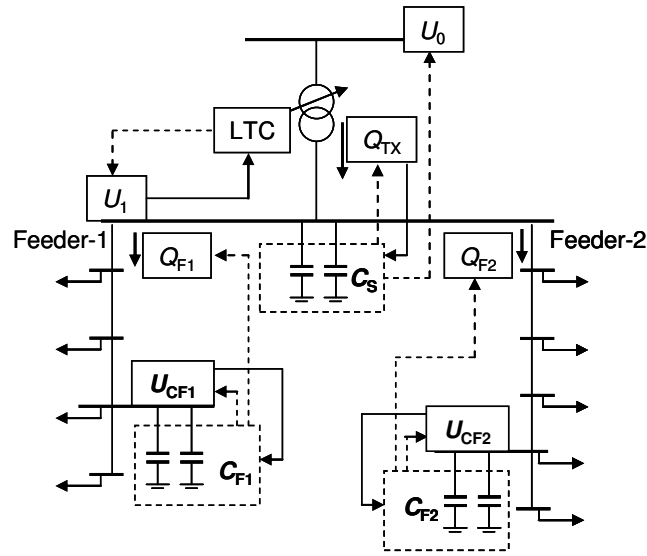

Figure 3.5. Conceptual diagram of the proposed local voltage and reactive power control.

The sequence of operation between the OLTC, substation capacitors and feeder capacitors are defined based on the following:

- The switching-on or off of the substation capacitors will increase or decrease the substation secondary voltage that might trigger the operation of the OLTC. On the other hand, reactive power flow on the substation transformer is hardly affected by the operation of the OLTC.
- The switching-on or off of the feeder capacitors will directly decrease or increase the reactive power flow through the transformer. On the other hand, though the switching-on or off of the substation capacitors will increase or decrease the voltage at the feeder capacitor connection points, the increase or decrease of the voltage will also depend on other factors, as given by Equation (3-10).

Therefore, in order to reduce the number of both OLTC and capacitor operations, the time delay of the OLTC and capacitors are set as

$$td_{FC} < td_{SC} < td_{OLTC} \quad (3-19)$$

where td is time delay; and subscript FC and SC indicates feeder capacitor and substation capacitor, respectively.

3.6 Case Study

The voltage and reactive power control presented in Section 3.5 is tested on a 10 kV distribution system fed from a 70 kV transmission system, shown in Figure 3.6, with its detailed specification presented in Table 3.1. The loads vary from minimum 0.4 pu to maximum 1.0 pu of the nominal load power with a daily profile as shown in Figure 3.7. The daily load profile is adapted from actual phasor measurements at one transmission-distribution grid in Gothenburg, Sweden, on 13 February 2006. The power flow calculations in this chapter, as well as in Chapter 4 and Chapter 5, are performed on DIgSILENT PowerFactory® [66].

TABLE 3.1
SPECIFICATIONS OF THE TEST SYSTEM

Transmission lines	$r = 0.15 \Omega/\text{km}$, $x = 0.5 \Omega/\text{km}$, $I_{\text{rated}} = 500\text{A}$, with following the lengths: Line 11-12 : 10 km Line 12-13 : 8 km Line 12-14 : 16 km Line 13-14 : 9 km
Distribution lines	$r = 0.12 \Omega/\text{km}$, $x = 0.35 \Omega/\text{km}$, $I_{\text{rated}} = 610\text{A}$, where the distances between two buses in Feeder-1 and Feeder-2 are 1.2 km and 1 km, respectively.
Loads	At Bus 12 and 13: 22 MW and 18 MW with 0.95 pf, respectively. Under Feeder-1 and Feeder-2: 1.8 MW and 1.4 MW at each bus, with 0.8 pf, respectively.
Transformer	70/10 kV, 18 MVA, $x = 12\%$, $x/r = 10$, OLTC at HV side, -10% to +10% regulation with 32 steps.
Capacitors	Substation Capacitors: 2 Mvar each. Feeder Capacitors: 1.4 Mvar each.

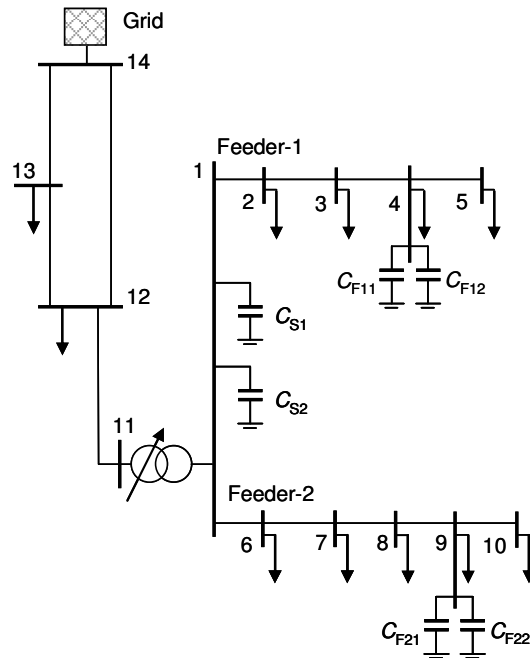

Figure 3.6. One line diagram of the system under study.

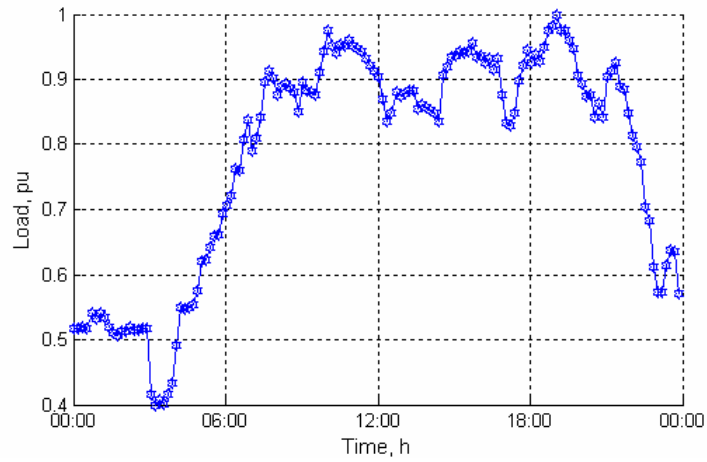

Figure 3.7. Daily load profile of the system under study.

3.6.1 Determination of OLTC and Capacitor Control Set Points

Table 3.2 shows voltage and voltage change quantities that determine the optimum control set points, which can be explained as follows:

- 1) $U_{LB,min}$ is the OLTC minimum lower boundary voltage, e.g., the voltage at bus-1 (U_1) that causes the voltage at one of the feeder-end to be equal to U_{min} at maximum load, with all feeder capacitors energized. The transformer rating and the line thermal capacity constraints, Equations (3-15) - (3-16), are never reached in this case study.
- 2) $U_{UB,max}$ is the OLTC maximum upper boundary voltage. As in conventional distribution systems, the voltage decreases along the feeder, the bus with the highest voltage will be the substation secondary bus. Hence, $U_{UB,max}$ is equal to U_{max} .
- 3) ΔU_{step} is the maximum substation secondary voltage change, at maximum load, due to one step of tap changer movement for any possible tap position with U_1 between $U_{LB,min}$ and $U_{UB,max}$.
- 4) $U_{OFF,max}$ is the maximum voltage at the capacitor buses that will not cause the voltage at any bus to exceed U_{max} , for any possible voltage variation with the OLTC setting specified in Table 3.4.
- 5) ΔU_{SW} is the maximum voltage change at the capacitor bus due to the capacitor switching, for any possible load and voltage variation with the OLTC and capacitor settings specified in Table 3.4.

TABLE 3.2
VOLTAGE AND VOLTAGE CHANGE [PU] THAT DETERMINE
THE OPTIMUM CONTROL SET POINTS

OLTC			C_{F11} and C_{F12}		C_{F21} and C_{F22}	
$U_{LB,min}$	$U_{UB,max}$	ΔU_{step}	$U_{OFF,max}$	ΔU_{SW}	$U_{OFF,max}$	ΔU_{SW}
0.995	1.05	0.009	1.05	0.04	1.05	0.04

Load Model and its Effect on the Optimum Control Set Points

Loads can be modelled as constant power, constant current and constant impedance characteristics by mathematically modelling the load as a voltage dependent load according to the following equation

$$P_D = P \left(\frac{U}{U_{rat}} \right)^\alpha \quad (3-20)$$

$$Q_D = Q \left(\frac{U}{U_{rat}} \right)^\beta \quad (3-21)$$

where

P_D and Q_D are the voltage dependent active and reactive power (the active and reactive power at a given voltage U), respectively

P and Q are the active and reactive power at the rated voltage U_{rat} .

α and β are 0, 1 and 2 for load with constant power, constant current and constant impedance characteristic, respectively. The load at a given voltage is the actual load, which will be simply called as *load*.

To get an overview on how the total load demand and losses are affected by the distribution system voltage control, the substation secondary voltage of the test system in Figure 3.6 is adjusted from 1.00 pu to 1.05 pu with 0.01 pu increment, by connecting a voltage source to it. The transformer and the transmission system are disconnected and the total load demand and losses in the distribution system are investigated. The results are shown in Table 3.3.

TABLE 3.3
TOTAL LOAD DEMAND AND LOSSES IN THE DISTRIBUTION SYSTEM FOR
VARIOUS SUBSTATION SECONDARY VOLTAGES

U_1	Constant Power			Constant Current			Constant Impedance		
	$P_{D,tot}$ [MW]	P_{Loss} [MW]	$\frac{P_{Loss}}{P_{D,tot}}$	$P_{D,tot}$ [MW]	P_{Loss} [MW]	$\frac{P_{Loss}}{P_{D,tot}}$	$P_{D,tot}$ [MW]	P_{Loss} [MW]	$\frac{P_{Loss}}{P_{D,tot}}$
1	14.2	0.329	2.32%	13.69	0.299	2.18%	13.26	0.276	2.08%
1.01	14.2	0.320	2.25%	13.83	0.299	2.16%	13.53	0.282	2.08%
1.02	14.2	0.312	2.20%	13.98	0.298	2.13%	13.80	0.287	2.08%
1.03	14.2	0.304	2.14%	14.13	0.298	2.11%	14.07	0.293	2.08%
1.04	14.2	0.300	2.11%	14.27	0.297	2.08%	14.34	0.298	2.08%
1.05	14.2	0.296	2.08%	14.42	0.297	2.06%	14.62	0.304	2.08%

It is indicated in Table 3.3 that different load models have different effects on losses and on losses per load, as follows:

- For a distribution system with constant *power* load, the losses will decrease with the increase of the distribution system voltage. Hence, in order to minimize losses, the distribution system should be operated at

highest possible voltage, as long as it does not exceed the maximum allowed voltage.

- For a distribution system with constant *current* load, the losses will almost not be affected by the change of the distribution system voltage. Hence, the selection of the distribution system operating voltage does not affect the objective function specified in Equation (3-13). However, as the load increases and the losses per load decreases with the increase of the voltage, the increase of the operating voltage will be favourable for the power producer and the decrease of the operating voltage will be favourable for the consumers.
- For a distribution system with constant *impedance* load, the losses will increase with the increase of the distribution system voltage, as an effect of the increase of the load. The losses per load will not change with the change of the distribution system voltage. Hence, when the objective of the distribution system voltage and reactive power control is to minimize losses, the distribution system should be operated at lowest possible voltage, as long as there will be no bus in the system experiencing undervoltage.

Further, when the distribution system consists of mixed types of loads, the characteristic of the mixed loads should be thoroughly investigated in order to find the optimum operating voltage of the system. For simplification, the distribution system in this case is assumed to have a single type of load, e.g., constant power type load. The reason for this selection is that, in the distribution systems with DG that will be investigated in the next chapter, the distribution system operation close to the maximum allowed voltage is more challenging.

Optimum Control Set Points

The optimum control set points of the OLTC and shunt capacitors are shown in Table 3.4, which can be explained as follows:

- 1) The OLTC bandwidth, U_{DB} , will determine how sensitive the OLTC reacts to a substation secondary voltage change. In this case study, U_{DB} is set to be around $2\Delta U_{step}$. Smaller U_{DB} can be set to let the OLTC operate closer to U_{set} , with the expense that it will cause the OLTC to operate more frequently.
- 2) The switching-off voltage of the feeder capacitor, U_{OFF} , must not be higher than $U_{OFF,max}$. In this case study, the losses do not decrease when the feeder capacitor is switched off while the capacitor bus voltage is equal to $U_{OFF,max}$.

but the capacitor must be switched off in order not to cause an overvoltage. Hence, U_{OFF} is set to be equal to $U_{OFF,max}$ for all feeder capacitors.

3) The switching-on voltage of the feeder capacitor, U_{ON} , should be set in such a way that, firstly, when the capacitor is switched on, the resulted voltage (at the capacitor connection point) will always be lower than U_{OFF} in order to prevent the capacitor from switching back to off following the switching-on. Secondly, it should be ensured that the switching-on of the capacitor will decrease the losses, which, in this case study, is mostly obtained when U_{ON} is set to be equal to $(U_{OFF} - \Delta U_{SW})$. Hence, U_{ON} is set to be a bit lower than $(U_{OFF} - \Delta U_{SW})$.

4) The minimization of the transformer losses can be achieved by minimizing the reactive power flow through the transformer, i.e., by setting the substation capacitor to switch on when the reactive power flow on the primary (to the secondary) side of the transformer is higher than the capacitor's rating ($Q_{ON} = Q_{C,rat}$) and to switch off when the reactive power flow on the secondary (to the primary) is higher than the capacitor's rating ($Q_{OFF} = Q_{C,rat}$).

5) The OLTC set point U_{set} is obtained by selecting the U_{set} that will minimize the total daily losses, e.g., when U_{set} is as high as possible.

TABLE 3.4
OPTIMUM OLTC AND CAPACITOR CONTROL SET POINTS

OLTC [pu]		C_{F11} and C_{F12} [pu]		C_{F21} and C_{F22} [PU]		C_{S1} and C_{S2} [MVAR]	
U_{set}	U_{DB}	U_{OFF}	U_{ON}	U_{OFF}	U_{ON}	Q_{ON}	Q_{OFF}
1.04	0.02	1.05	1.005	1.05	1.005	2	-2

3.6.2 Simulation Results

Operating Constraints

The transformer rating and the line thermal capacity constraints indicated in Equations (3-15) - (3-16) are never reached in this case study. Hence, the fulfilment of the operating constraints for any possible load condition can be investigated from the voltage profiles at some important buses, e.g., substation buses, feeder capacitor buses and feeder-end buses. The voltage profiles at these important buses are shown in Figure 3.8. The figure indicates that, in all

cases, the voltages stay within the allowed range given by Equation (3-14) all the time.

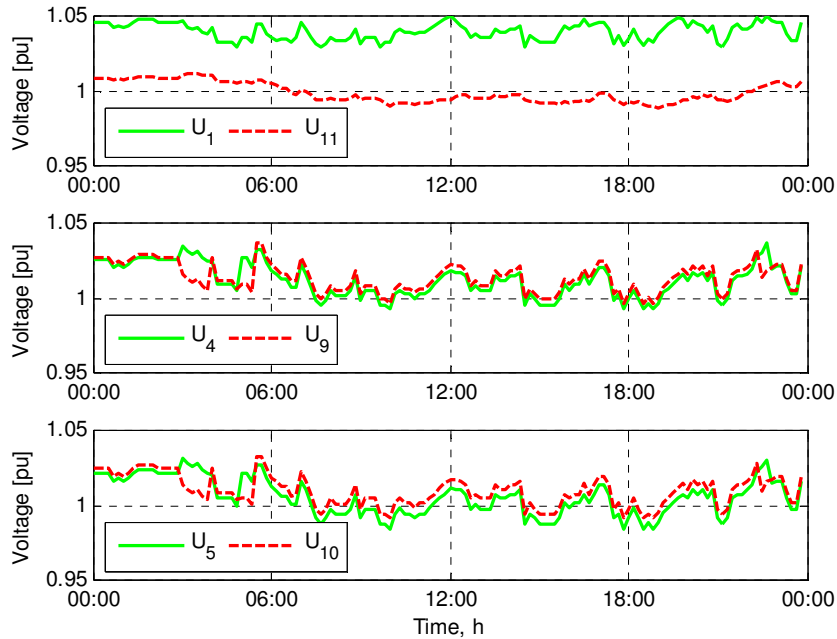

Figure 3.8. Voltage profile at some selected buses in Figure 3.6.

The voltage at bus-1 (the substation secondary bus voltage) will vary between U_{LB} and U_{UB} (see Table 3.4 and Equation (3-4)). As the voltage in conventional distribution systems decreases towards the end, the voltage at bus-1 will be higher than the voltage at any other bus in the distribution system, except when the feeder capacitor excessively compensates the reactive power demand where the voltage at the feeder capacitor bus can be higher than the substation secondary bus voltage.

The voltage at bus-11 (the substation primary bus voltage) is mostly affected by the active and reactive power supplied to the distribution system. The effect of the reactive power flow to the voltage at bus-11 explains how the substation capacitor affects the substation primary voltage.

The voltage at the feeder capacitor buses (bus-4 and bus-9) may exceed the maximum allowed voltage when the feeder capacitor excessively compensates the reactive power demand. A proper setting of the feeder capacitor (see Table 3.4) mitigates this problem. As in this case study, the same load profile is applied to all loads in the distribution system, the voltage at bus-4 and bus-9 will have the same pattern, except when the status of the

feeder capacitors at these buses are different, as can be seen by comparing the voltages at bus-4 and bus-9 in Figure 3.8 with the status of the feeder capacitors at bus-4 and bus-9 in Figure 3.9.

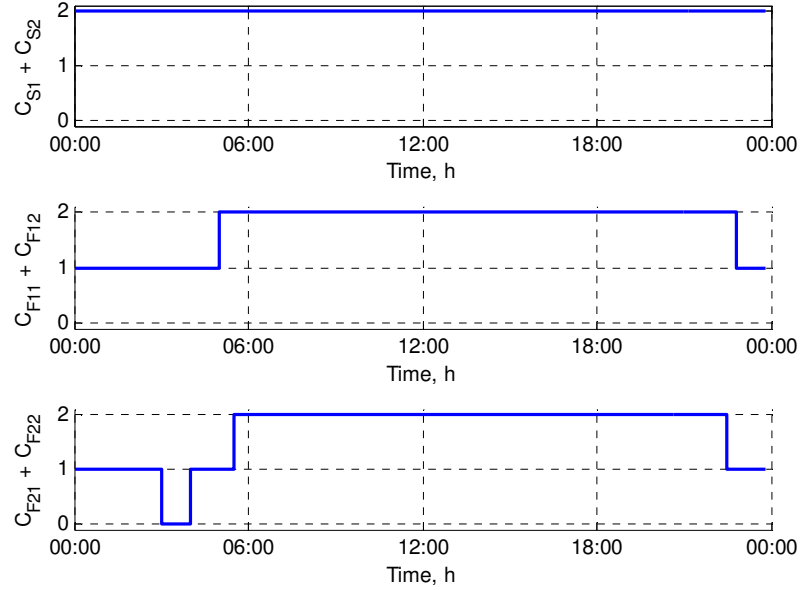

Figure 3.9. Status of the capacitors in Figure 3.6.

Buses with the lowest voltage in conventional distribution systems will be buses at feeder-ends, e.g. bus-5 and bus-10 in this particular case study. The voltages at bus-5 and bus-10 buses are affected by the feeder capacitors at bus-4 and bus-9, respectively. Hence, the voltages at bus-4 and bus-9 have the same pattern as the voltages at bus-5 and bus-10, respectively.

Objective Function and Other Indices

In order to investigate how the proposed local voltage and reactive power control will minimize losses, decrease the number of OLTC operations and reduce voltage fluctuation, the proposed voltage and reactive power control was compared with voltage and reactive power control where the capacitors are controlled by timers (which is here called as *conventional voltage and reactive power control*), which is still commonly used nowadays [37].

As previously explained, a time controlled capacitor does not have any flexibility to respond to the load fluctuation, since it is not based on any

measurements. Hence, the OLTC and capacitors are set in a conservative way, according to the typical load pattern, in such a way that a deviation from the typical load fluctuation will not cause the voltage to exceed U_{\max} . Hence, U_{UB} will not be set to be equal to U_{\max} as in Table 3.4. Further, when the load ramps up (according to the typical load profile), the feeder capacitor will not be set to switch on at the time where the switching-on of the capacitor will decrease losses, but will wait until the load increases further. Furthermore, when the load ramps down, the feeder capacitors will be set to switch off before the load reaches a level where the presence of the capacitor causes overvoltage.

For example, Table 3.5 shows one example of the setting of the OLTC and feeder-1 capacitor timers. The feeder-2 capacitor timer is set to 10 minutes after the corresponding feeder-1 capacitor timer, in order to limit the level of voltage variation due to simultaneous switching of two capacitors. The substation capacitors are never switched off, which is the same as shown in Figure 3.9.

The daily losses, the daily number of OLTC operations and the voltage fluctuations with the proposed method and with the conventional method are shown in Table 3.6. The voltage fluctuation UF in the table is the average voltage fluctuation of all buses from bus-1 to bus-11. The table shows that the losses, the number of OLTC operations and the voltage fluctuations decrease with the proposed method. The most significant reduction is obtained for the number of OLTC operations. This significant reduction will obviously be beneficial for the DNO, as this reduction directly correlates to the decrease of the OLTC maintenance cost and the increase of the OLTC life time expectancy.

TABLE 3.5
OLTC CONTROL AND CAPACITOR TIMERS FOR THE CONVENTIONAL METHOD

OLTC [pu]		C_{F11} [h]		C_{F12} and C_{F22} [H]	
U_{set}	U_{DB}	t_{ON}	t_{OFF}	t_{ON}	t_{OFF}
1.02	0.02	05:00	21:30	07:00	00:00

TABLE 3.6
COMPARISON BETWEEN THE PROPOSED AND THE CONVENTIONAL METHOD

	Losses [MWh]	No. of OLTC Operation	UF [%]
Proposed Method	6.4	24	0.331
Conventional Method	7.0	36	0.372

The significant reduction of the number of OLTC operations with the proposed method is achieved because the capacitors operate according to the actual load fluctuation. Thus the operation of the capacitors will be in line with the need of the OLTC to regulate the voltage, and thereby will contribute to the reduction of the number of OLTC operations. On the other hand, in the conventional method, as the operation of the capacitor does not follow the actual load fluctuation, the capacitor operation can be contradictory to the need of the OLTC to regulate the voltage.

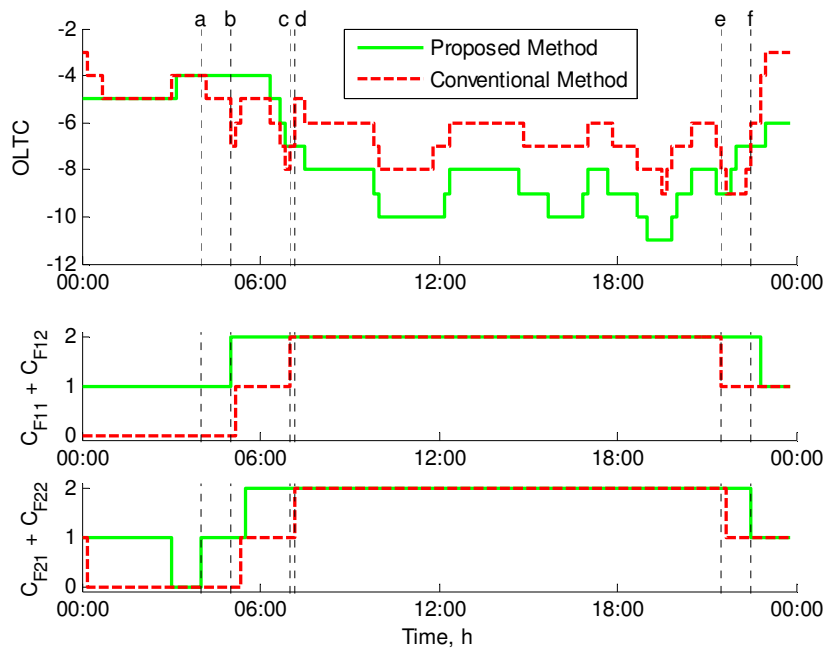

Figure 3.10. OLTC and capacitor status with proposed and conventional method.

The alignment and the contradiction between the capacitor and the OLTC operation with the proposed method and with the conventional method, respectively, can be seen from the OLTC and capacitor status in Figure 3.10. For example, when the feeder capacitor is switched according to the proposed method (see the capacitor status for the proposed method under the line marked with 'a', 'b' and 'e'), the OLTC does not operate (see the corresponding OLTC status for the proposed method), but when the capacitor is not switched (see the corresponding capacitor status for the conventional

method), the OLTC will operate either immediately or after a further load increase or decrease (see the corresponding OLTC status for the conventional method). On the other hand, when the feeder capacitor is switched according to the conventional method (see the capacitor status for the conventional method under the line marked with 'c', 'd' and 'f'), the OLTC will operate (see the corresponding OLTC status for the conventional method).

3.7 Conclusions

In this chapter, voltage and reactive power control in conventional distribution systems has been evaluated. On-load tap-changers (OLTCs) and switched shunt capacitors as the main voltage and reactive power control equipment in distribution systems have been briefly described.

The voltage profile in conventional distribution systems is shown to decrease towards the end of the feeder. Hence, the voltage in conventional distribution system is regulated mainly based on how to counteract the voltage drop.

A proper coordination among OLTC, substation shunt capacitors and feeder shunt capacitors, without requiring communication among them, has been presented. The OLTC regulates the substation secondary bus voltage, substation capacitors maintains the substation primary bus voltage and feeder capacitors maintain the voltages on the feeder, as a supplement to the voltage regulation by the OLTC, and compensate the reactive power demand on the feeder.

The simulation results indicate that, compared to the conventional method where the capacitors are time controlled, the proposed method has been shown to decrease the losses, the voltage fluctuation and the number of OLTC operations. The decrease in the number of OLTC operations is the most significant reduction. Further, the simulation results show that, for conventional distribution systems with constant power load, setting the OLTC and the capacitor controllers in such a way that the distribution system operates close to its maximum allowed voltage will minimize losses.

Chapter 4

Local Voltage and Reactive Power Control in the Presence of Distributed Generation

This chapter presents an analysis of the performance of the local voltage and reactive power control in the presence of distributed generation (DG). It starts with a basic overview of the possible impact of DG on voltage and reactive power control. The impact of DG on the local voltage and reactive power control is then examined in a case study. The DG considered here is the one where its voltage or reactive power can be controlled, e.g., synchronous machines based DG, with dispatchable power output. Comparative analysis between different possible DG operations is presented. Results related to this chapter are published in Paper VII.

4.1 Introduction

It has been presented in Chapter 3 that the distribution system voltage and reactive power control equipment are mostly operated based on an assumption that the power flows in one direction only, from the transmission system to the HV/MV substations and then to the distribution systems. Thus, the voltage decreases along the feeder, from the substation to the feeder-end. The presence of DG makes this assumption no longer valid. The power generated by DG will increase the voltage, which may cause the voltage at its connection point to be higher than the voltage at the substation. Further, when the DG power is high, the power may flow from the distribution system to the transmission system.

Hence, the presence of DG will affect the voltage and reactive power control in distribution systems [9]. Therefore, the connection of DG needs to be coordinated with the available voltage and reactive power control

equipment in order to ensure that the distribution system will not lose the proper voltage regulation. Coordination between DG and OLTC is shown in [28] and [41] to be necessary to allow a higher level of DG penetration. In [42], coordination between DG and switched capacitors is presented. The coordination is introduced in order to ensure that the voltage rise caused by the DG will not cause any overvoltage when the capacitors are energized.

Different methods to mitigate the voltage and reactive power control problem in the presence of DG have been addressed. In [43]-[44], the installation of a step voltage regulator (VR) on the feeder is presented to solve unacceptable voltage variations. Overvoltage can also be mitigated by operating DG in leading pf (DG absorbs reactive power from the grid) [45]. Further, operating feeders in a closed loop can also solve unacceptable voltage variations by balancing the voltage between the feeders in the loop [41]. These methods will also lead to a larger DG installation potential in the distribution system. However, VR installation means an additional investment cost. DG absorbing reactive power needs reactive power sources somewhere else in the system that will increase losses. Closed loop feeder operation needs attention on the short circuit capacity and protection of the feeder. Comparative analysis between different methods to solve unacceptable voltage variation and to increase the maximum allowed DG size has been presented in Chapter 5 of the licentiate thesis.

Modification to the existing OLTC by using multiple load drop compensations with multiple pilot buses, on a multi-feeders distribution system with DG, is proposed in [46]. This method is based on system wide coordination of voltages using remote control, real time measurement, communication and optimization. This method is suitable for a distribution system with multiple feeders, where some of the feeders have an undervoltage problem due to high load while some others have an overvoltage problem due to high DG power output. This method needs a major modification of an existing OLTC control system, which typically has been in service for many decades. This may make distribution network operators (DNOs) reluctant to implement this method.

A similar approach, e.g., based on system wide coordination of voltages and power flows using remote control, real time measurement, communication and optimization, but keeping the conventional OLTC without any major modification, is presented in [45]. Like the previous method, this method calls for the modernization of the medium voltage distribution systems.

The coordination between DG and the available voltage and reactive power control equipment, described in this chapter, is based on the local voltage and reactive power control that has been explained in Chapter 3. All

equipment, including DG, are coordinated without communication links. This method is suitable when the DG is connected to traditional distribution systems, where the application of remote control, real time measurement, communication and optimization has not been accommodated yet.

The DG considered here is the one where its voltage or reactive power can be controlled, e.g., synchronous machine DG, with dispatchable power output, such as gas turbines for CHP applications. DG with uncontrollable voltage or reactive power, and with varying power output following the availability of the energy input, will be investigated in Chapter 5.

The case study in Chapter 3 is extended with DG present in the system. Comparative analysis between different possible DG operation modes, at unity power factor, at lagging power factor and at a constant voltage, is presented.

4.2 DG Impact on Voltage Drop

DG can be connected to the grid directly using synchronous or induction generators or through a power electronic interface. Synchronous generators or power electronic interfaced DG can be operated at various modes of the reactive power. The DG either generates or absorbs reactive power or the DG does not exchange reactive power with the distribution system. Synchronous generators or power electronic interface based DG can also be involved in the distribution system voltage control, i.e., when the DG is operated at a constant voltage by varying its reactive power output. On the other hand, induction generator based DG always absorbs reactive power.

For a system with load and DG as shown in Figure 4.1, the voltage drop on the feeder can be approximated by

$$\begin{aligned}\Delta U &= U_1 - U_2 \\ &\approx \frac{R_{LN}(P_L - P_{DG}) + X_{LN}(Q_L - (\pm Q_{DG}))}{U_2}\end{aligned}\quad (4-1)$$

which indicates that if the DG generates reactive power or the DG does not exchange reactive power with the grid, the DG will always decrease the voltage drop along the feeder. If the generated power is larger than the feeder load, power will flow from the DG to the substation and causes a voltage rise. Further, Equation (4-1) indicates that, if the DG absorbs reactive power, the DG can either increase or decrease the voltage drop. This depends on the DG

active and reactive power relative to the load active and reactive power and the X/R ratio of the line.

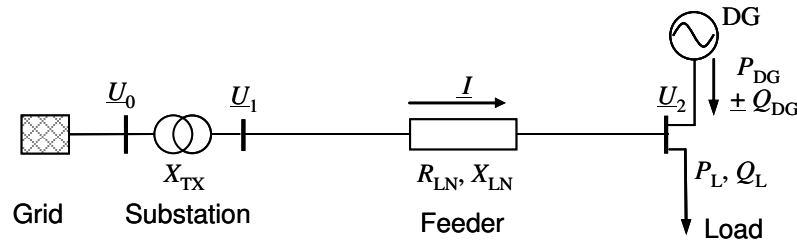

Figure 4.1. One line diagram to illustrate the voltage drop in a distribution system with DG.

4.3 Maximum DG allowed capacity

Three technical factors that limit the maximum DG capacity are fault levels, thermal limits and voltage limits [45]. Fault level limits will not be discussed in this thesis. The thermal and voltage limits of the distribution system have basically been covered in the distribution system voltage and reactive power control constraints that have been explained in Section 3.5.

Normally, before allowing the installation of DG, the DNO will ensure that the voltage, line thermal capacity and substation transformer capacity constraints, as presented in Section 3.5, will not be violated for the worst operating scenarios characterized by [44]:

- no generation and maximum load
- maximum generation and maximum load
- maximum generation and minimum load.

The maximum generation and maximum load can be the limit for the DG capacity when the DG absorbs reactive power and increases the voltage drop in the feeder, in the case of induction DG for instance [47]. Here, the DG bus voltage at maximum generation and maximum load can be lower than the minimum allowed voltage.

Meanwhile, the maximum generation and minimum load will be the limit for the DG capacity when: 1) the DG power causes a voltage rise where the DG bus voltage is higher than the maximum allowed voltage; 2) the DG reverse current is higher than the conductor's thermal limit; 3) the DG reverse power to the substation exceeds the thermal capacity of the substation transformer.

Limiting the DG allowed capacity based on the worst case operating conditions should be accompanied with the adjustment of the distribution system voltage control, otherwise the DG capacity will be unnecessarily restricted [28], [41], [45]. For example, when the maximum generation and minimum load is the limit for the maximum DG allowed capacity, the reduction of the OLTC set point voltage will increase the maximum DG allowed capacity. Meanwhile, when the maximum generation and maximum load is the limit for the maximum DG allowed capacity, the increase of the OLTC set point voltage will increase the maximum DG allowed capacity. Adjustment of the OLTC set point voltage to increase the maximum DG allowed capacity has been discussed in Chapter 5 of the licentiate thesis.

4.4 DG Impact on Voltage and Reactive Power Control

It has been explained in Chapter 3 that, losses in conventional distribution systems with constant power load can be minimized by operating the distribution system close to the maximum allowed voltage U_{\max} . This is obtained by setting the OLTC upper boundary voltage U_{UB} and the feeder capacitor switching-off voltage U_{OFF} equal to U_{\max} (see Table 3.4). This approach will be used as the basis for the analysis of the impact of different DG operation on the voltage and reactive power control that will be presented in the subsections hereafter. The analysis will be focused on the impact on OLTC and feeder capacitor control set points and voltage variation in the system.

4.4.1 DG Operated at Varying Voltage

Consider the one line diagram shown in Figure 4.2 with DG present in the feeder. The DG does not control its terminal voltage. When the DG causes a voltage rise between bus-3 and bus-4, setting U_{OFF} equal to U_{\max} may cause an overvoltage at bus-4. This can happen when U_{\max} is almost reached at bus-3, when the feeder capacitor is energized. Hence, the feeder capacitor set point voltage may need to be decreased with the presence of DG, in order to prevent overvoltage at DG buses.

Furthermore, with the OLTC keeping U_2 nearly constant, the increase of the voltage profile along the feeder due to the DG may cause U_3 higher than

U_{OFF} when the feeder capacitor is still expected to generate reactive power to compensate the reactive power demand and minimize losses. Hence, the OLTC set point voltage may need to be decreased with the presence of DG, in order not to cause feeder capacitors unnecessarily disconnected when they are still expected to generate reactive power.

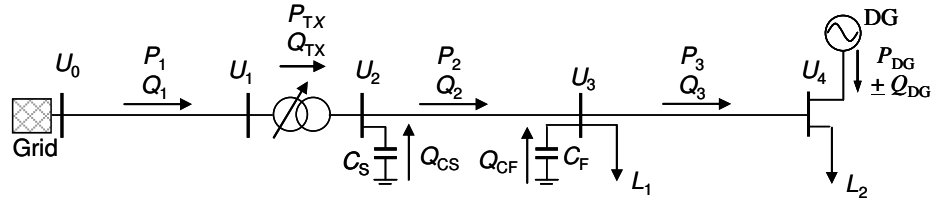

Figure 4.2. One line diagram to illustrate the DG impact on voltage and reactive power control.

The impact of DG on the voltage variation can be analyzed by assuming that the load in Figure 4.1 increases from $P_{L,1}$ and $Q_{L,1}$ to $P_{L,2}$ and $Q_{L,2}$, with the DG power constant. Due to this load increase, the load bus voltage will decrease from $U_{2,1}$ to $U_{2,2}$, which can be approximated as

$$U_{2,1} - U_{2,2} \approx \frac{R_{LN}(P_{L,2} - P_G) + X_{LN}(Q_{L,2} - (\pm Q_G))}{U_{2,2}} - \frac{R_{LN}(P_{L,1} - P_G) + X_{LN}(Q_{L,1} - (\pm Q_G))}{U_{2,1}} \quad (4-2)$$

Equation (4-2) indicates that, when the DG power does not change and the DG generates reactive power or does not exchange reactive power with the distribution system, the presence of the DG decreases the voltage change due to the load change. In the case that the DG absorbs reactive power, the impact will depend on the DG active and reactive power relative to the load active and reactive power and the X/R ratio of the line.

4.4.2 DG Operated at a Constant Voltage

DG operated at a constant voltage is getting involved in the voltage control of the distribution system by controlling the reactive power output in the excitation system. The response of the excitation system (td_{DG}) is faster than the response of the capacitors (td_{FC} , td_{SC}) and that of the OLTC (td_{OLTC}). Hence the time delay of the DG excitation, OLTC and capacitors are related as:

$$td_{DG} < td_{FC} < td_{SC} < td_{OLTC} \quad (4-3)$$

The DG will be able to control its terminal voltage as long as the voltage is within the DG reactive power capability limits, specified by

$$Q_{DG}|_{\min} \leq Q_{DG} \leq Q_{DG}|_{\max} \quad (4-4)$$

Now consider the one line diagram shown in Figure 4.2 where U_4 is kept constant by controlling the DG reactive power output. With U_4 kept constant, the voltage change following the load change in the whole distribution system can be expected to be smaller than the case when U_4 also changes due to the load change. Similarly, the voltage change due to the OLTC will also be smaller.

With smaller voltage variation in the feeder capacitor bus, it can be expected that the need to decrease the OLTC set point voltage, in order to prevent unnecessary disconnection of feeder capacitor, can be eliminated. Smaller voltage changes following the OLTC operations also mean that the OLTC bandwidth can be decreased without causing the OLTC to operate excessively. Hence, the OLTC set point voltage can be increased in order to operate the distribution system even closer to its maximum allowed voltage and to decrease losses further.

4.5 Case Study

The local voltage and reactive power control presented in Section 3.5, in the presence of DG, is tested on the system shown in Figure 4.3. This system is the same as the test system for the case study in Section 3.6, except that the 4 x 3 MVA and 3 x 3 MVA DGs are now connected to bus-3 and bus-10, respectively. The DG simulated in this study is the synchronous generator based DG.

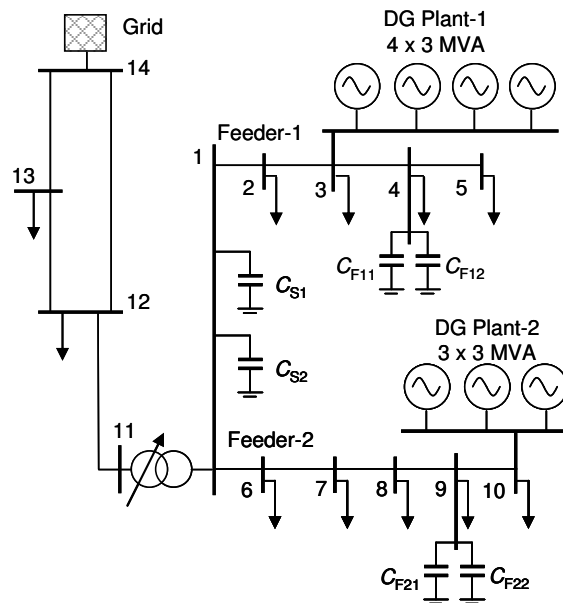

Figure 4.3. One line diagram of the system under study.

All other specifications of the system are kept the same as the ones shown in Table 3.1 and Figure 3.7. It has been verified that the presence of DG does not cause the voltage, line thermal capacity or substation transformer capacity constraints in Section 3.5 to be violated in the worst operating scenarios.

Three different cases are investigated, DG operated at unity pf (*unity pf* case), DG generating constant reactive power $Q_G = 0.423$ Mvar (*lagging pf* case) and DG operated at constant voltage with reactive power limits $Q_{G,\min} = -0.423$ Mvar and $Q_{G,\max} = 0.423$ Mvar (*constant voltage* case). In order to get a direct comparison of the effect of the different DG operating modes on the losses, the DG is set to generate constant active power $P_G = 2.97$ in all the cases.

In the lagging pf case, the DG operates at 0.99 lagging pf, whereas in the constant voltage case, the DG has reactive power capability between 0.99 lagging and 0.99 leading pf. These values are not selected based on the common DG reactive power capability but to illustrate how a small amount of DG reactive power can contribute to the voltage and reactive power control.

DG absorbing reactive power is not simulated in this case study as it is not realistic to operate DG to absorb reactive power while a large amount of reactive power flows from the transmission system to the distribution system.

4.5.1 Determination of OLTC and Capacitor Control Set Points

The voltage and voltage change quantities that determine the optimum control set points are shown in Table 4.1. As a comparison, the voltage and voltage change quantities without DG are also presented. The description of each quantity has been given in Section 3.6.1 for the case without DG, which remains the same for the case with DG, except for $U_{UB,max}$. In the case with DG, $U_{UB,max}$ is defined as the value of U_1 that causes the voltage at one of the generator buses to be equal to U_{max} , having maximum generation and minimum load, with all feeder capacitors switched off.

TABLE 4.1
VOLTAGE AND VOLTAGE CHANGE [PU] THAT DETERMINE
THE OPTIMUM CONTROL SET POINTS

	OLTC			C_{F11} and C_{F12}		C_{F21} and C_{F22}	
	$U_{LB,min}$	$U_{UB,max}$	ΔU_{step}	$U_{OFF,max}$	ΔU_{SW}	$U_{OFF,max}$	ΔU_{SW}
No DG	0.995	1.05	0.009	1.05	0.04	1.05	0.04
Unity pf	0.995	1.035	0.008	1.048	0.04	1.042	0.04
Lagging pf	0.995	1.015	0.007	1.048	0.04	1.039	0.04
Constant voltage	0.995	1.05	0.003 0.007*	1.048	0.008	1.047	0.005

*: DG is beyond the capability limits

TABLE 4.2
OPTIMUM OLTC AND CAPACITOR CONTROL SET POINTS

	OLTC [pu]		C_{F11} and C_{F12} [pu]		C_{F21} and C_{F22} [pu]		C_{S1} and C_{S2} [Mvar]	
	U_{set}	U_{DB}	U_{OFF}	U_{ON}	U_{OFF}	U_{ON}	Q_{ON}	Q_{OFF}
No DG	1.04	0.02	1.05	1.005	1.05	1.005	2	-2
Unity pf	1.014		1.048	1.005	1.042	0.997		
Lagging pf	1.005		1.048	1.005	1.039	0.995		
Constant voltage	1.045	0.01	1.048	1.038	1.047	1.041		

Table 4.1 indicates that, in all cases with DG, the voltage change due to the OLTC operation is smaller than in the case without DG, where the highest reduction is obtained when the DG is operated at a constant voltage. This confirms the DG impact on voltage changes that has been explained in Section 4.4.

Based on the quantities shown in Table 4.1, the optimum control set points of the OLTC and capacitors are then obtained as shown in Table 4.2. The description of each quantity has been given in Section 3.6.1 for the case

without DG, which remains the same for the case with DG, except for U_{set} . In the case without DG, U_{set} is as high as possible in order to minimize losses. In the case with DG, U_{set} for the minimization of the total daily losses is obtained from the optimization process.

4.5.2 Simulation Results

Optimum Feeder Operating Voltage

As has been explained in Section 3.5, the considered optimum feeder operating voltage is the feeder operating voltage that will minimize losses, according to the given objective function. Losses are proportional to the square of the current, and the current of a constant power load is inversely proportional to the voltage. Hence, the minimization of the feeder losses can be achieved by operating the feeder as close as possible to the maximum allowed voltage U_{max} , as long as the feeder capacitor is not caused to switch off when the capacitor is still expected to generate reactive power.

In the case without DG, the feeder capacitor is the only source of voltage increase in the feeder. Hence, a higher voltage at the capacitor connection point than at the substation secondary bus is an indication that the capacitor reactive power compensation is no longer effective for loss reduction, as the capacitor excessively, or almost excessively, compensates the reactive power demand. Therefore, the loss minimization can be achieved by setting the OLTC $U_{\text{set}} = U_{\text{UB,max}} - 0.5U_{\text{DB}}$.

The presence of DG increases the voltage profile along the feeder. For the unity pf case, operating the feeder close to U_{max} ($U_{\text{set}} = U_{\text{UB,max}} - 0.5U_{\text{DB}}$) will cause the feeder capacitors to easily reach their switching-off voltage when they are still expected to generate reactive power, which will increase losses. On the other hand, if U_{set} is set too low ($U_{\text{set}} = U_{\text{LB,min}} + 0.5U_{\text{DB}}$), the line current will increase, which will also increase losses. The increase of losses due to the increase of line current appears is as indicated in Figure 4.4, where on two peak hours (around 11 and 19 o'clock), $U_{\text{set}} = 1.025$ pu gives the lowest losses and $U_{\text{set}} = 1.005$ pu results in the highest losses.

DG operated at lagging pf results in the highest voltage increase, which causes U_{max} to be reached by a lower U_{set} . In this particular case, $U_{\text{UB,max}}$ equals to $(U_{\text{LB,min}} + U_{\text{DB}})$ on maximum generation and minimum load. Hence, there is no flexibility in adjusting U_{set} to minimize losses.

For the constant voltage case, the voltage at the DG connection point can be kept constant by the DG excitation. Hence, similar to the case without DG, the losses will be minimal when the feeder is operated close to U_{max} , i.e., by

setting the OLTC $U_{\text{set}} = U_{\text{UB,max}} - 0.5U_{\text{DB}}$ and setting the generator to operate at $U_G = 1.05$ pu.

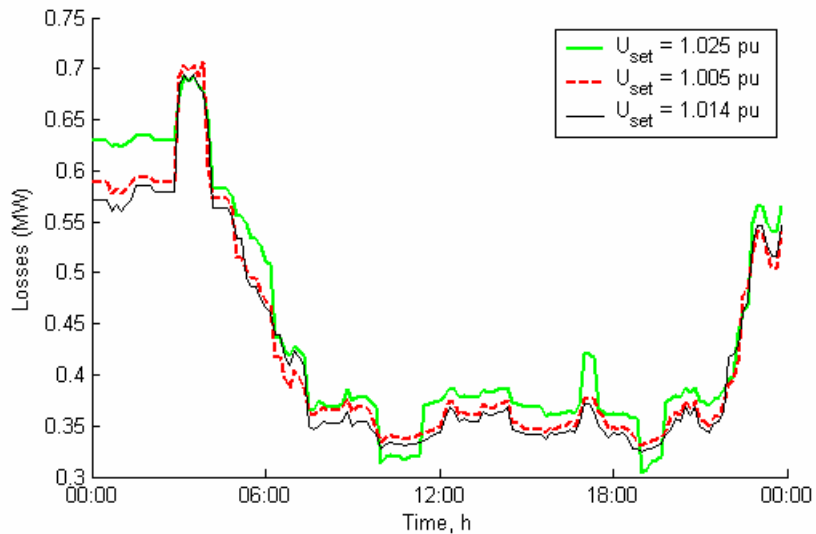

Figure 4.4. Losses in the distribution system with DG operated at unity pf and three different OLTC set point.

Operating Constraints

In the same way as in the case without DG explained in Section 3.6.2, the transformer rating and the line thermal capacity constraints, indicated in Equations (3-15) - (3-16), are never reached. Hence, the fulfilment of the operating constraints for any possible load condition can be investigated from the voltage profiles at some important buses, e.g., substation buses, feeder capacitor buses, DG buses and feeder-end buses. The voltage profiles at those important buses are shown in Figure 4.5 - Figure 4.7. The figures indicate that, in all cases, the voltages always stay within the allowed range given by equation (3-14).

DG operated at a constant voltage is shown, in Figure 4.5 - Figure 4.7, to result in the lowest voltage variation, as has been explained in Section 4.4.2. Further, the figures also show that the voltages at the feeder buses (not at the substation) most of the time are higher with DG than without DG. This confirms the impact of DG on the voltage profile explained in Section 4.2: for a DG generating reactive power or a DG having no exchange of reactive

power with the grid, the DG will always decrease the voltage drop along the feeder.

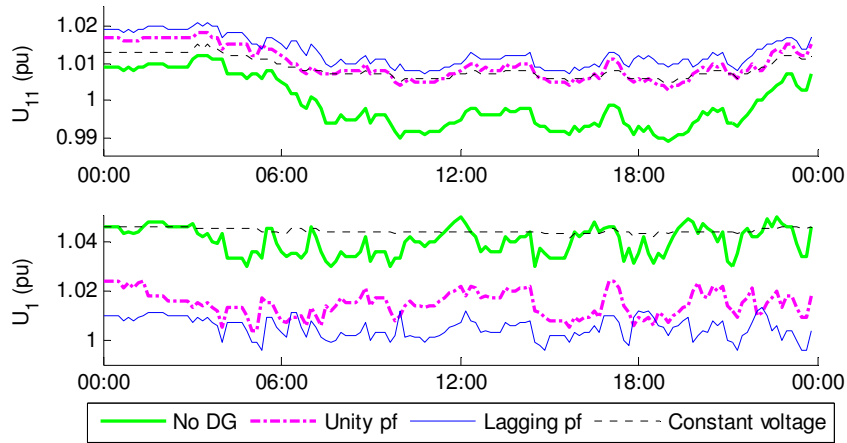

Figure 4.5. Voltage profile at substation buses.

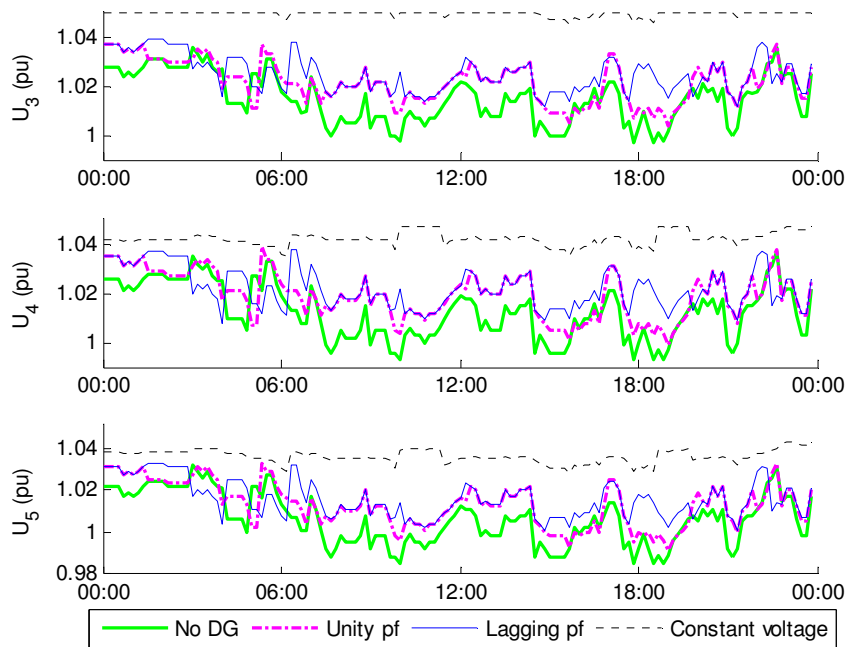

Figure 4.6. Voltage profile at selected buses in feeder-1.

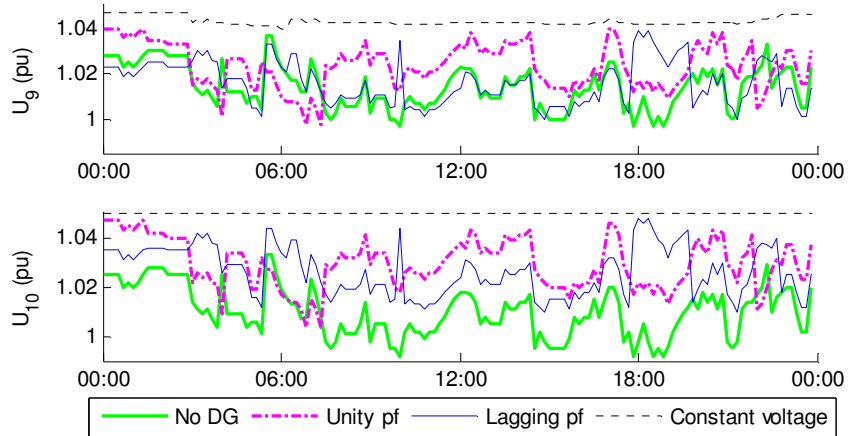

Figure 4.7. Voltage profile at selected buses in feeder-2.

The influence of the OLTC and capacitors to the voltage profile is similar as in the case without DG that has been explained in Section 3.6.2. The voltage at bus-1 (the substation secondary bus voltage) is dominantly affected by the OLTC settings (see Table 4.2). The voltage at bus-11 (the substation primary bus voltage) is affected by the active and reactive power to/from the substation. All OLTC, feeder capacitors and DG have an influence on the voltages at bus-3, bus-4, bus-5 and bus-9 and bus-10, except for the constant voltage case where the voltages at bus-3 and bus-10 are almost fully determined by the DG.

Objective Function and Other Indices

The lowest voltage variation with DG operated at a constant voltage that has been shown in Figure 4.5 - Figure 4.7 can also be seen from the daily voltage fluctuations at each bus in Figure 4.8. Further, the figure also shows that the voltage fluctuation for the unity pf case and lagging pf case is lower than the voltage fluctuation without DG. This is the direct impact of the decrease of voltage change due to the load change with the presence of DG generating reactive power or DG without reactive power exchange, as explained in Section 4.4.

A decrease of the voltage change due a load change will result in a reduction of the number of OLTC operations, as shown in Table 4.3. The table even shows that when the DG operates at a constant voltage, the OLTC

does not operate at all, as the DG excitation responds to the voltage change and keeps the substation secondary bus voltage to always vary within $U_{LB} < U_1 < U_{UB}$. The reason for this is that the response time for the DG excitation is shorter than that of the OLTC.

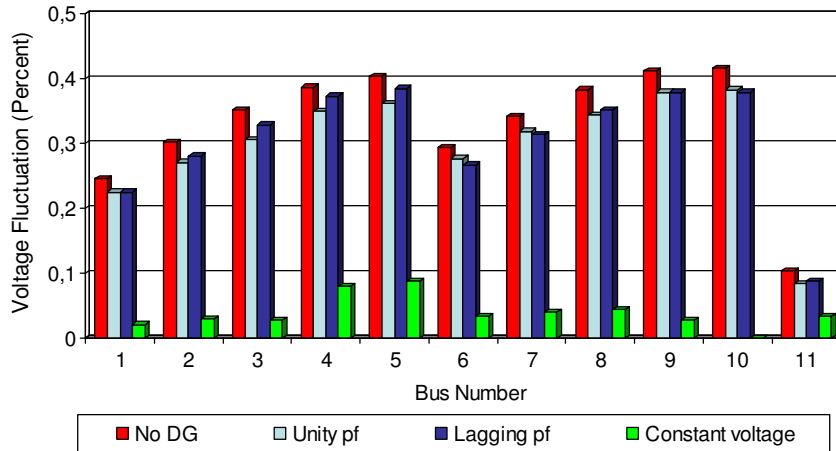

Figure 4.8. Daily bus voltage fluctuation for different cases.

From the reduction of both the voltage fluctuation and the number of OLTC operations, it can be concluded that the DG operated at a constant unity pf, lagging pf, or a constant voltage with dispatchable active power; will not interfere with the effectiveness of the OLTC operation. It will even decrease the number of OLTC operations significantly.

The distribution system losses in different cases are shown in Table 4.3. It is indicated that the DG generating constant reactive power will result in lower losses than the DG operating at unity pf. The available feeder capacitors are not sufficiently large all the time to compensate the reactive power demand. Hence, the lacking reactive power is supplied by the DG. In the case where the DG reactive power replaces the capacitor reactive power, the losses are not significantly different. This is illustrated by Figure 4.9. The loss reduction from the unity pf case to the lagging pf case is more significant when feeder capacitors energized in both cases are equal. These are the cases within the time intervals indicated by two vertical lines 'a', 'b' and 'c', respectively.

The daily losses, with and without DG, are shown in Table 4.3. It is shown that the losses in the cases with DG are higher than the losses in the case without DG. In principle, when DG is small, the DG will decrease the

losses in the feeder and the losses will decrease further when the size is increased until a certain size. A further increase of the DG size will then increase the losses. The impact of DG on losses is also dependent of the DG location. The impact of the DG size and location to the losses has been discussed in Chapter 3 of the licentiate thesis, and will not be discussed further in this thesis.

TABLE 4.3
DAILY NUMBER OF OLTC OPERATIONS AND LOSSES FOR DIFFERENT CASES

	Daily Number of OLTC Operations	Daily Loses [MWh]
No DG	24	6.43
Unity pf	8	10.16
Lagging pf	6	10.09
Constant voltage	0	9.96

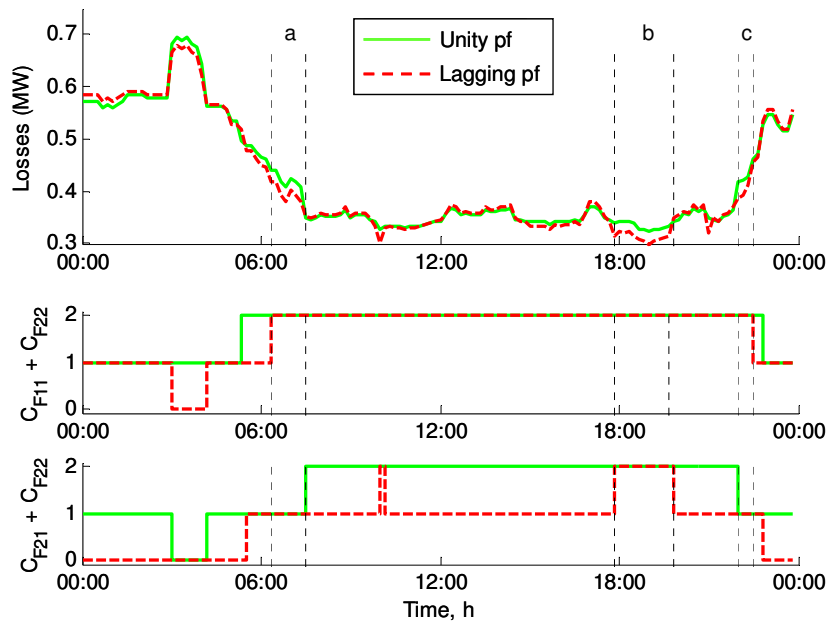

Figure 4.9. Losses and the status of feeder capacitors for two different cases.

Distribution systems without DG were discussed in Chapter 3. The simulation results in Section 3.6.2 showed the proposed local voltage and reactive power control will result in lower losses, lower number of OLTC

operations and lower voltage fluctuations, compared to conventional control. The same results are obtained when DG is present in the system, as shown in Table 4.4, where the unity pf case is taken as the example. To get a comparison, the results for the case without DG are also presented. The results in Table 4.4 are obtained by setting the OLTC and feeder capacitors as the ones shown in Table 4.5. The decrease of the OLTC set point and the duration of capacitors energization in the case with DG is an anticipation to the voltage increase due to the presence of the DG.

TABLE 4.4
COMPARISON BETWEEN THE PROPOSED AND THE CONVENTIONAL METHOD

	No DG			Unity pf		
	Losses [MWh]	No. of OLTC Operation	UF [%]	Losses [MWh]	No. of OLTC Operation	UF [%]
Proposed	6.4	24	0.331	10.2	8	0.300
Conventional	7.0	36	0.372	10.8	30	0.304

TABLE 4.5
OLTC CONTROL AND CAPACITOR TIMERS FOR THE UNITY PF CASE
WITH THE CONVENTIONAL METHOD

	OLTC [pu]		C_{F11} [h]		C_{F12} and C_{F22} [h]	
	U_{set}	U_{DB}	t_{ON}	t_{OFF}	t_{ON}	t_{OFF}
No DG	1.02	0.2	05:00	21:30	07:00	00:00
Unity pf	1.01		05:30	21:00	08:00	

Finally, it can be seen from Table 4.4 that a significant reduction of the number of OLTC operations with the presence of the DG can only be obtained when the available voltage and reactive power control equipment are properly coordinated.

4.5.3 The Need of Control Set Points Readjustment

It has been discussed in Section 3.6.1 that, in distribution systems with only constant power load, the optimum OLTC set points will mostly not be affected by the change of the load. But when DG is connected to such a distribution system, the optimum OLTC set point will easily be affected by

the change of the load and the DG power, as can be concluded from Figure 4.4.

Hence, in order to keep the effectiveness of the voltage and reactive power control, periodic readjustment of the control set points may be needed for the case with DG. In general, this should be anticipated based on the following:

- The major component of load variations is related to weather conditions and a more deterministic pattern of hourly and daily variations caused by social activities [38]. Typical load profiles are then formed on seasonal basis. Hence, the control set points of the proposed voltage and reactive power control may need to be readjusted on a seasonal basis as well. This adjustment is basically a normal practice in conventional distribution systems with loads mixed between constant power, constant current and constant impedance.
- The method is intended for a system with DG generating constant power output by taking into account the worst operating scenarios specified in Section 4.3. Hence, the change of DG availability due to planned outages will, in most cases, not bring the voltage beyond the allowed voltage variation. A temporary change of the DG availability may motivate a readjustment of the control set points in order to minimize losses. However, the cost for a temporary readjustment has to be compared with the gain by decreasing the losses. On the other hand, the installation of new DG should be followed by readjustment of both OLTC and feeder capacitor control set points.
- The alteration of the substation capacitors control set points are not needed as the set points are optimal for any operating conditions.

4.6 Conclusions

In this chapter, the local voltage and reactive power control that has been explained in Section 3.6 is evaluated with DG connected to the system. The DG considered here is the one where its voltage or reactive power can be controlled, with dispatchable power output.

The voltage profile in the distribution system is shown to increase with the presence of DG. Hence, the presence of DG needs to be coordinated with the available voltage and reactive power control equipment in order to ensure that the DG will not cause the operating constraints to be violated, and that the DG size is not unnecessarily limited.

It has been concluded in Chapter 3 that operating conventional distribution systems with constant power load close to the maximum allowed voltage will minimize losses. However, the conditions will change when DG is present in the system, as the feeder capacitors can switch off when the reactive power demand is still considerably high.

The optimum operating voltage of the distribution system with DG then needs to be obtained from an optimization process, by considering the load, the DG power and the DG operation mode. Hence, the change of load or of the DG output can easily affect the optimum feeder operating voltage. This should not be a problem for distribution systems with a typical load profile in a long term and with DG output almost constant all the time, as the selected operating voltage will be optimum in a long term.

It has been demonstrated that the power flow reversal due to the DG will not interfere with the effectiveness of the on-load tap-changer (OLTC) operation. The presence of the DG under consideration in this chapter even decreases the voltage fluctuation and significantly decreases the number of OLTC operations in the system. Note that a significant reduction of the OLTC operations will only be obtained when the OLTC, capacitors and DG are properly coordinated.

Finally, it has been shown that when the feeder capacitors available in the feeder are sufficient to compensate the reactive power demand, the DG operation mode does not have a significant effect on the distribution system losses. However, the number of OLTC operations and the voltage fluctuation in the system will be reduced significantly when the DG is operated at a constant voltage.

Chapter 5

Coordinated Voltage and Reactive Power Control in the Presence of Distributed Generation

This chapter presents coordinated voltage and reactive power control, to improve the local voltage and reactive power control that has been investigated in Chapter 3 and Chapter 4. Both cases, without and with distributed generation (DG) involved in the voltage control are treated. The case of DG with varying power output and uncontrollable reactive power is also included.

Results related to this chapter are published in Paper VIII and Paper XIII.

5.1 Introduction

OLTC and shunt capacitors can be controlled locally, manually through SCADA and automatically centralized [48]. Locally controlled OLTC and shunt capacitors have been presented in Chapter 3 for the case without DG and in Chapter 4 for the cases with synchronous machine DG.

When the OLTC and capacitors are controlled locally, based on pre-determined control set points, the set points are selected in a conservative way in order to keep the voltage at all buses in the system within the allowed range for all possible load variations during a considerably long period. This is because a frequent alteration of the OLTC and capacitor controllers is not practical in many cases.

It has been presented in Chapter 4 that when DG is present in the distribution system with local voltage and reactive power control, the optimum feeder operating voltage loss minimization can only be obtained based on an optimization process, by considering the load, DG power and DG operation mode. In this case, the change of either load or DG will influence

the optimum operating voltage. In this case, losses will not be minimized all the time.

The local voltage and reactive power can be improved, in order to minimize losses all the time, by developing a short term operation planning based on optimization for the forecasted operating conditions. The plan then needs to be executed with the aid of remote control and communication links. Methods for a short term operation planning have been used in transmission systems for many years [49]-[51]. In line with the modernization of electricity distribution, these methods have been adopted into the distribution systems. Different methods for short term operation planning have been proposed to improve the local (*uncoordinated*) voltage and reactive power control in distribution systems [36]-[37], [52].

An overview of coordinated voltage and reactive power controls in transmission systems will be presented in the next section. This will then be followed by a literature review of coordinated voltage and reactive power control in distribution systems. An alternative coordinated voltage and reactive power control based on automated remote adjustment to the local voltage and reactive power control method, without and with DG involved in the voltage control, is then proposed. The remote adjustment schedule is obtained from an optimization process for a one-day-ahead load forecast and a one-day to a few-hours-ahead DG power forecast. The equipment that will be remotely dispatched are OLTC, *substation capacitors* (the shunt capacitors installed at substation secondary bus) and DG, if the DG is involved in the voltage control.

The proposed combined local and remote voltage and reactive power control will simply be called *coordinated voltage and reactive power control*. This method is intended for distribution systems where the feeder capacitors (the shunt capacitors located somewhere along the feeder) are not provided with communication links. Hence, the feeder capacitors will be fully operated by their local voltage controller.

There are two objectives that will be examined in the proposed method. When the DG is not involved in the voltage control, the objective is to minimize losses in the distribution system. When DG is included in the voltage control, the objective is extended further to maximize the use of reactive power from the available shunt capacitors to reserve the DG reactive power for emergency.

The proposed methods are tested in two case studies. The first case study is voltage and reactive power control with induction machine DG. As has been explained, such a system always absorbs reactive power from the grid and does not have capability to control its terminal voltage. Both DG with dispatchable power output and DG with variable power output, representing

small hydro power and small wind power applications, respectively, are evaluated. The study starts with the investigation of the impact of the induction machine DG on the local voltage and reactive power control, to complement the investigation of the impact of synchronous machine DG in Chapter 4. The coordinated voltage and reactive power control to improve the local voltage and reactive power control, with its cost and benefit, is then presented.

The second case study is coordinated voltage and reactive power control with synchronous machine DG, representing combined heat and power (CHP) application. Both cases, without and with DG involved in the voltage control, are treated. The coordinated voltage and reactive power control is presented by using the same test system as in Chapter 4.

5.2 Coordinated Voltage and Reactive Power Control in Transmission Systems

For many years, voltage and reactive power control in a large power system has been decomposed into three hierarchical levels; the primary, secondary and tertiary levels. The levels are characterized by different operation time (from a few seconds to several minutes) and different operation areas (local, regional and national or larger area) [49]-[50].

The primary control is performed by automatic voltage regulators (AVRs) installed on synchronous generators. The AVR keeps the generator terminal voltage constant. The AVR operates rapidly, in a time frame of a few seconds.

The secondary control consists of the modification of the set point values of the AVR, the switching of reactive power compensation devices (capacitors, inductors, synchronous or static compensators, etc.) and the change of tap positions of OLTCs. The secondary voltage control has response times longer than the AVR, from several seconds to a few minutes. The main objective of the secondary control is to maintain the voltage profile and reactive power flow inside a network area. The operation in the secondary voltage control is mainly justified by local measurements.

The tertiary control is aimed to determine an optimum voltage profile of the network and to coordinate the secondary controllers according to security and economic criteria.

The optimum voltage profile in the tertiary control is determined from an optimization for the forecasted operating conditions. Based on that, a short time operation planning is then developed. Remote control, real time

measurement, communication as well as load and generator forecasting play a vital role in the tertiary voltage control operation.

Different approaches have been proposed for the tertiary voltage control [49]-[52]. For example, in [49] the short time operation planning is formed in a one-day-ahead voltage and reactive power scheduling based on hydro-thermal coordination and load forecasting, where the objective is loss minimization for the most representative time interval of the daily forecasted load. If the actual operation states are then significantly different from the forecasted ones, the forecasted voltage profiles and reactive power flow will no longer be optimal and are sometimes even infeasible. The very short operation rescheduling will then be executed on the basis of the actual operation states (given by the on-line state estimation) and of the very short term load forecasting.

5.3 Brief Overview on Coordinated Voltage and Reactive Power Control in Distribution Systems

As explained in Chapter 3, the voltage and reactive power control in distribution systems has for many years been based on local operation of the OLTC, shunt capacitors and steps voltage regulators. However, in line with the modernization of electricity distribution, coordinated voltage and reactive power control with short term operation planning has been adopted into distribution systems. Different short term operation planning methods have been proposed to improve the local voltage and reactive power control.

For example, in [36]-[37], a short time operation planning is deployed to an hourly automatic dispatch of OLTC, substation capacitors and feeder capacitors, based on a one-day-ahead load forecast. This method fully replaces the local control operation of the OLTC and capacitor operations with a remote control. The drawback of this full remote control method is that the OLTC and the capacitor will lose their capability to react on load changes that deviate from the ones forecasted.

In [53], the OLTC is controlled by considering the dispatch schedule of all capacitors in order to reduce the number of OLTC operations. Firstly, a dispatch schedule of capacitors is determined based on a one-day-ahead load forecast. The capacitor schedule is then used as the basis for the change of OLTC set point voltage, which is controlled in real time to cover the difference between the actual and the forecasted load.

The methods in [36]-[37] and [53] depend on communication links to all capacitors in the feeders. However, though most high voltage/medium

voltage (HV/MV) substations are remotely controllable, many distribution utilities do not have communication links downstream to the feeder capacitor locations.

DG is normally not involved in the voltage control in the distribution system, though synchronous machine DG has an inherent feature to perform automatic voltage control, with a response time that is much faster than the operation of the OLTC and the mechanically switched shunt capacitors. Hence, in principle, involving DG in voltage control of the distribution system should improve the voltage regulation in the distribution system. For example involving DG in the voltage control will result in a significant reduction of the number of OLTC operations and voltage fluctuation in the distribution system, as has been presented in Chapter 4.

By involving DG in the coordinated voltage control, the voltage control in the distribution systems will be similar to the coordinated voltage control in transmission systems, where the voltage control is deployed into three hierarchical levels. The primary control is performed by the DG. The secondary control is performed by locally operated OLTCs and switched capacitors. Meanwhile, the tertiary control is performed by remotely adjusting DG, OLTC and capacitors, if required, in order to obtain an optimum voltage profile.

It has been presented in Chapter 4 that, when the DG is operated in voltage control mode and the feeder capacitor is controlled by a voltage controller, the capacitor is not maximally used. On the other hand, the capacitor reactive power is considerably cheaper than the DG reactive power (by assuming that the capacitor has already been available in the distribution system). Hence, coordinated voltage control involving DG can be used to maximize the utilization of reactive power from the existing shunt capacitors.

Further, as DG has a fast dynamic characteristic and the mechanically switched capacitor does not, the unused DG reactive power will be the reactive power reserve during a grid fault. The de-energized capacitor will not play the same role. Hence, maximizing the utilization of capacitors will have a potential benefit in increasing the reactive power reserves for emergency purpose.

5.4 Proposed Coordinated Voltage and Reactive Power Control

As other coordinated voltage and reactive power methods that have been explained, the proposed method will also depend on remote control to

remotely dispatch the voltage and reactive power equipment in an automated schedule. The dispatch schedule is obtained from an optimization process for a one-day-ahead load forecast and a one-day to a few-hours-ahead DG power forecast. The equipment that will be remotely dispatched are OLTC, substation capacitors and DG, if the DG is involved in the voltage control.

The proposed method is intended for distribution systems where the feeder capacitors are not provided with communication links. Hence, the feeder capacitors are not remotely dispatched and will be fully operated by their local voltage controller instead. However, the voltage at the feeder capacitor connection point can be altered by dispatching the other voltage and reactive power equipment, to force the feeder capacitors on or off by their own local controller.

5.4.1 Coordinated Voltage and Reactive Power Control without DG Involved

As has been explained, it is unlikely that the losses will be minimal all the time with local voltage and reactive power control. Interventions to the locally controlled OLTC and capacitors operations based on a wide coordination may be needed. Hence, loss minimization is set as the objective of the proposed coordinated voltage and reactive power control.

The conceptual diagram of the proposed voltage and reactive power control is shown in Figure 5.1. The OLTC is controlled by, and will maintain, the substation secondary bus voltage U_1 within a certain range. The substation capacitors are controlled by the transformer reactive power flow Q_{TX} and will maintain the substation primary bus U_0 . The feeder capacitors are controlled by, and will maintain, their local bus voltage U_{CF1} and U_{CF2} , and they will also affect the reactive power flow on their feeder Q_{F1} and Q_{F2} . The OLTC and substation capacitors are adjusted remotely based on automated schedules.

The optimization of the voltage and reactive power control will be based on a one-day-ahead load forecast and three-hours-ahead DG output forecast, for DG with variable output. Three-hours-ahead DG output forecast is taken to anticipate the possible error of a one-day-ahead DG power forecast, where the DG considered here is small wind power generation. While the load forecast errors are not sensitive to the forecast horizon, from a few hours to one day ahead, the wind power forecast error increases with an increasing of the forecast horizon [53]. Some references use two or three-hour-ahead wind power forecast for different studies, such as for quantifying reserve demand in systems with significant installed wind capacity [53] and for determining the optimal operation and management of an autonomous wind-diesel power

system [54]. The three-hour-ahead wind power forecast is therefore adopted here, assuming this forecast to be as accurate as the one-day-ahead load forecast.

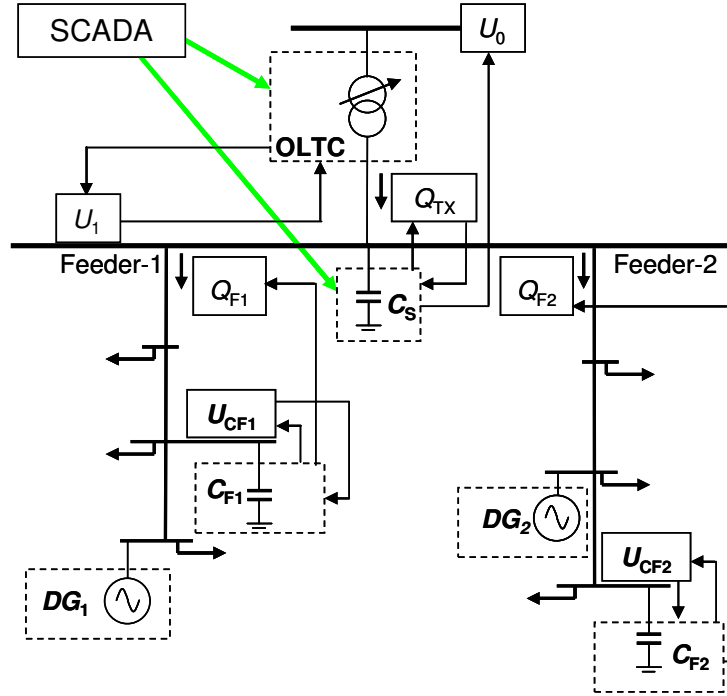

Figure 5.1. Conceptual diagram of the proposed voltage and reactive power control without DG involved.

The coordinated voltage and reactive power control is executed based on the following algorithm:

- 1) For the forecasted load profile and DG output, a set of OLTC tap positions and capacitor statuses in a day, based on their local control operation for predetermined control set points, can be obtained based on the following inequality equations

$$TAP_{i+1} = \begin{cases} TAP_i + 1 & \text{if } U_{1,i} > U_{UB} \\ TAP_i & \text{if } U_{LB} \leq U_{1,i} \leq U_{UB} \\ TAP_i - 1 & \text{if } U_{1,i} < U_{LB} \end{cases} \quad (5-1)$$

$$SCF_{i+1} = \begin{cases} ON & \text{if } SCF_i = OFF \text{ and } U_{CF,i} < U_{ON} \\ SCF_i & \text{if } U_{ON} \leq U_{CF,i} \leq U_{OFF} \\ OFF & \text{if } SCF_i = ON \text{ and } U_{CF,i} > U_{OFF} \end{cases}, \quad (5-2)$$

∀ feeder capacitors

$$SCS_{i+1} = \begin{cases} ON & \text{if } SCS_i = OFF \text{ and } Q_{TX,i} < Q_{ON} \\ SCS_i & \text{if } Q_{ON} \leq Q_{TX,i} \leq Q_{OFF} \\ OFF & \text{if } SCS_i = ON \text{ and } Q_{TX,i} > Q_{OFF} \end{cases}, \quad (5-3)$$

∀ substation capacitors

where

- TAP_i = OLTC tap position at time i
- U_{LB} = OLTC lower boundary voltage
- U_{UB} = OLTC upper boundary voltage
- SCF_i = feeder capacitor status at time i
- SCS_i = substation capacitor status at time i
- ON = switch to on
- OFF = switch to off
- U_{ON} = switching-on voltage of the feeder capacitor
- U_{OFF} = switching-off voltage of the feeder capacitor
- Q_{ON} = switching-on reactive power of the substation capacitor
- Q_{OFF} = switching-off reactive power of the substation capacitor

Note that the OLTC is located at the primary side of the transformer. Lowering the OLTC tap position means increasing the substation secondary bus voltage and raising the OLTC tap position means decreasing the substation secondary bus voltage.

- 2) By using dynamic programming, the optimum OLTC tap positions and capacitor statuses in a day can be obtained. Taken all possible OLTC tap positions and capacitor statuses will obviously need an extremely large computational effort. For example, if the OLTC has 17 steps, there are 6 capacitors in the system and 96 time stages in a day (with 15 minutes interval between two subsequent stages), there will be $96 \times (2^6 \times 17)$ possible states. However, there are only few reasonable states that need to be examined. This is because, firstly, the optimum feeder capacitor status at time i can be predicted from the optimum feeder capacitor status at time

$i-1$ and the load change from time $i-1$ to i . For example, when the feeder capacitor status at time $i-1$ is optimum, the load increase from time $i-1$ to i will never request the switching off of the feeder capacitor. Secondly, the optimum substation capacitor status at time i can be predicted from the reactive power flow on the substation transformer. For example, when reactive power is flowing from the primary to the secondary of the transformer, switching off of the substation capacitor will always increase losses. Lastly, for system with constant power loads that is investigated here, higher U_1 (which is driven by the OLTC) will always create lower losses as long as the voltage increase does not cause the feeder capacitors to switch off.

- 3) By comparing step 1 and step 2, a remote dispatch schedule can be defined. In defining the schedule, it should be ensured that the operating constraints are fulfilled. The operating constraints considered here are the ones used for the local voltage and reactive power control discussed in Section 3.5. Additionally, the number of the remote dispatches should be limited and the number of the OLTC operations should not increase excessively. For example, it is assumed that the maximum number of remote dispatch is one in an hour, and the remote operation should not cause an OLTC counter operation within the next one hour.

The mathematical expressions of the objective function and inequality constraints are the same as the objective function and inequality constraints in Equations (3-13) - (3-16). The daily number of OLTC operations as expressed in equation (3-17) is also evaluated. Additionally, the daily number of capacitor switchings, given by the following equation, will be examined

$$DC = \sum_i^{96} (SC_{k,i} \oplus SC_{k,i-1}), \forall \text{ capacitors} \quad (5-4)$$

where

- DC = daily number of capacitor switchings
- $SC_{k,i}$ = status of capacitor- k at time i
- \oplus = exclusive OR operation,
 - $SC_{k,i} \oplus SC_{k,i-1} = 1$ if $SC_{k,i} \neq SC_{k,i-1}$
 - $SC_{k,i} \oplus SC_{k,i-1} = 0$ if $SC_{k,i} = SC_{k,i-1}$.

5.4.2 Coordinated Voltage and Reactive Power Control with DG Involved

As has been explained, when the DG is operated at voltage control mode and the feeder capacitor is controlled by a voltage controller, the capacitor reactive power may not be maximally used. On the other hand, the capacitor reactive power is considerably cheaper than the DG reactive power, and the unused DG reactive power can be used for reactive power reserve in an emergency, meanwhile the de-energized capacitor can not. Hence, in addition to the loss minimization, maximization of the utilization of existing shunt capacitors is set as an additional objective function.

The conceptual diagram of the proposed voltage and reactive power control with DG involved is shown in Figure 5.2. The diagram is an extension of the diagram in Figure 5.1, by adding local and remote voltage control to the DG. In the figure, the DG is intended to perform the primary voltage control, the locally operated OLTC and capacitors to perform the secondary voltage control and remote adjustment of OLTC, substation capacitors and DG as the tertiary voltage control.

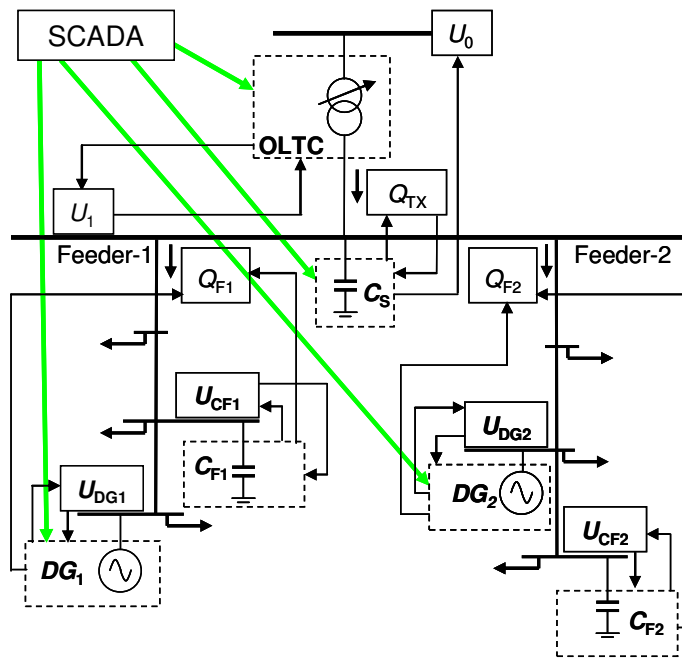

Figure 5.2. Conceptual diagram of the proposed voltage and reactive power control with DG involved.

The minimization of losses and maximization of capacitor utilization as the objective function of the coordinated voltage and reactive power control with DG involved can be mathematically written as

$$J = \min \sum_{i=1}^N \left(C_1 P_{Loss,i} - C_2 \sum_{j=1}^{NC} SC_{j,i} \right) \quad (5-5)$$

where

- C_1, C_2 = coefficient factor for losses and capacitor utilization, respectively
- $SC_{j,i}$ = status of capacitor- j at time i , 1 if the capacitor is on and 0 if the capacitor is off
- NC = number of capacitors in the system.

The operating constraints will include the voltage, current and transformer capacity as in the voltage control without DG involved, plus DG reactive power capability specified by the following inequality

$$Q_{DG,j} \Big|_{\min} \leq Q_{DG,j,i} \leq Q_{DG,j} \Big|_{\max}, \forall \text{ DGs} \quad (5-6)$$

where

- $Q_{DG,j,i}$ = reactive power output DG- j at time i
- $Q_{DG,j} \Big|_{\min}$ = minimum reactive power output of DG- j
- $Q_{DG,j} \Big|_{\max}$ = maximum reactive power output of DG- j .

5.5 Case Study with Induction Machine DG

The system under study is shown in Figure 5.3, where a 10 kV distribution system is fed from a 70 kV transmission system, with detailed specification presented in Table 5.1. For consistency with the local voltage and reactive power control in Chapter 3 and Chapter 4, loads are considered as constant power type, the same as in Chapter 3 and Chapter 4.

The induction machine DG is connected through a generator transformer. The shunt capacitor for the DG compensation is connected at the low voltage (LV) bus, with two-steps compensation. The first step is 1 Mvar that switches on following the energizing of the DG, and the second step is another 0.33 Mvar that will switch on when the DG power exceeds 80% of the rating. With that reactive power compensation, the DG system will always consume reactive power. It has been verified that, with these loads and DG, none of the

operating constraints in Equations (3-14) - (3-16) are violated for the worst operating conditions specified in Section 4.3.

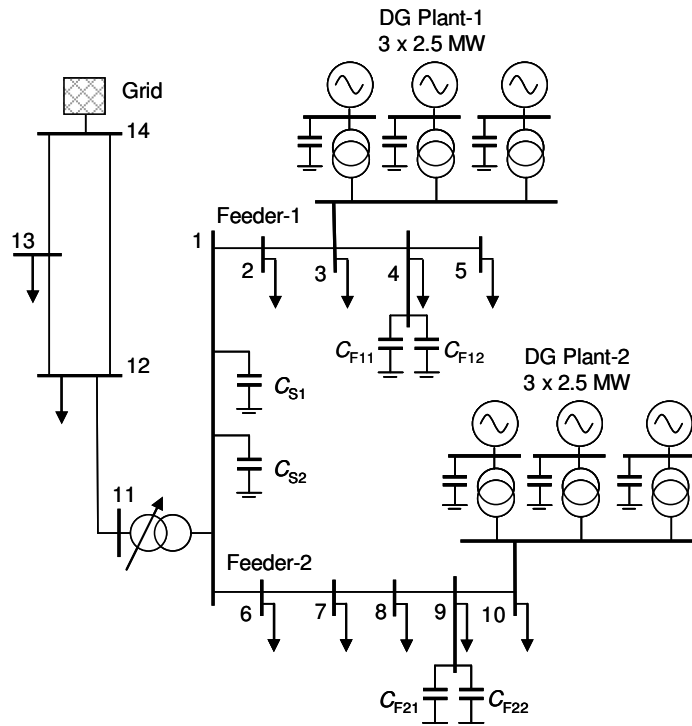

Figure 5.3. One line diagram of the system under study for the cases with induction machine DG.

The investigation is started with the case without DG. The cases with DG are then analyzed comparatively to the case without DG. Two induction machine DG operations are presented; DG generates dispatchable power output representing small hydro power application (*dispatchable* case) and DG generates varying power representing small wind power application (*non-dispatchable* case).

The time interval between two subsequent stages under study is 15 minutes for the load and 30 minutes for the wind power, with the profiles as shown in Figure 5.4. The local control set points of the OLTC and the capacitors are presented in Table 5.2. Note that the set points are not optimized according to the forecasted load and wind power profiles, as the load and wind power profile and its level will keep changing on a daily basis. However, the set point is optimum for the case without DG.

TABLE 5.1
SPECIFICATIONS OF THE TEST SYSTEM IN FIGURE 5.3

Transmission lines	$r = 0.15 \Omega/\text{km}$, $x = 0.5 \Omega/\text{km}$, $I_{\text{rated}} = 500\text{A}$, with the following lengths: Line 11-12: 15 km Line 12-13: 12 km Line 12-14: 25 km Line 13-14: 15 km
Distribution lines	$r = 0.12 \Omega/\text{km}$, $x = 0.35 \Omega/\text{km}$, $I_{\text{rated}} = 610\text{A}$, where the distance between two buses is 1.5 km.
Loads	At Bus 12 and 13: 22 MW and 18 MW with 0.95 pf, respectively. Under Feeder-1 and Feeder-2: 1.3 MW and 1.2 MW at each bus, with 0.8 pf, respectively.
Substation Transformer	70/10 kV, 18 MVA, $x = 12\%$, $x/r = 10$, OLTC at HV side, -10% to +10% regulation with 16 steps.
Capacitors	Substation Capacitors: 2 Mvar each. Feeder Capacitors: 1.25 Mvar each.
DG Transformer	10/0.69 kV, 3.5 MVA, $x = 10\%$, $x/r = 10$.
DG	Induction generators with the following specifications: $S = 3.03 \text{ MVA}$, $P = 2.5 \text{ MW}$, $U = 0.69 \text{ kV}$, pf = 0.86.

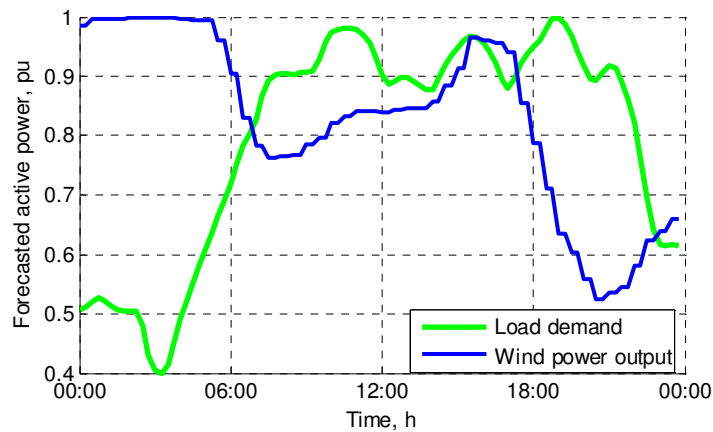

Figure 5.4. Forecasted load demand and wind power output of the case study with induction machine DG.

TABLE 5.2
SETTINGS OF THE OLTC AND CAPACITORS

OLTC [pu]		Feeder Capacitors [pu]		Substation Capacitors [Mvar]	
U_{set}	DB	U_{ON}	U_{OFF}	Q_{ON}	Q_{OFF}
1.035	0.03	0.99	1.05	-2.0	2.0

5.5.1 Voltage Change due to Load Change, Capacitor Switching and OLTC Operation

It has been explained in Section 4.4.1 that the induction machine DG (DG absorbs reactive power) can either increase or decrease the voltage change due to the load change, which depends on the DG active and reactive power relative to the load active and reactive power and the X/R ratio of the line. This impact is significantly different from synchronous machine DG (DG generates reactive power or does not exchange reactive power with the grid), where the DG always decreases the voltage change due to the load change.

The voltage change at the substation secondary bus due to a 0.05 pu load increase of the system under study is presented in Table 5.3. The load is increased from the indicated level, while the OLTC and all the capacitors in the system remain unchanged. It is shown that the voltage change is much higher when DG is present and operates at its rating (2.5 MW), than when there is no DG in the system. On the other hand, the voltage change with and without DG, will approximately be equal when the DG operates at 60% of its rating. This can be explained qualitatively from equation (4-2) in Section 4.4.1. With the line reactance approximately three times the line resistance, the DG reactive power increasing the voltage change becomes significant when the DG absorbs a large amount of reactive power (e.g., when the DG generates a large amount of active power).

Similarly, the voltage change due to the operation of the OLTC and capacitor will increase significantly when the DG operates at its rating and will be almost unchanged when the DG operates at 60% of the rating, as shown in Table 5.4 and Table 5.5. The values in these tables are obtained by keeping all voltage and reactive power control equipment, except the one under consideration, unchanged. The voltage change due to the operation of the OLTC and the feeder capacitor is an important aspect in defining the voltage and reactive power control strategy, which will be discussed in the sections hereafter.

TABLE 5.3
VOLTAGE CHANGE [PU] AT SUBSTATION SECONDARY BUS DUE TO
A 0.05 PU LOAD INCREASE FROM THE INDICATED LEVELS

	$P_L = 0.4\text{pu}$	$P_L = 0.6\text{pu}$	$P_L = 0.8\text{pu}$
Without DG	0.013	0.015	0.017
With DG, $P_{DG} = 1.5\text{ MW}$	0.013	0.014	0.016
With DG, $P_{DG} = 2.5\text{ MW}$	0.018	0.022	0.028

TABLE 5.4
VOLTAGE CHANGE [PU] AT SUBSTATION SECONDARY AND CAPACITOR BUSES
DUE TO THE SWITCHING OF FEEDER CAPACITOR C_{F21}

	At bus-1		At bus-9	
	$P_L = 0.4\text{pu}$	$P_L = 0.8\text{pu}$	$P_L = 0.4\text{pu}$	$P_L = 0.8\text{pu}$
Without DG	0.014	0.015	0.044	0.046
With DG, $P_{DG} = 1.5\text{ MW}$	0.017	0.019	0.05	0.053
With DG, $P_{DG} = 2.5\text{ MW}$	0.028	0.037	0.075	0.098

TABLE 5.5
VOLTAGE CHANGE [PU] AT SUBSTATION SECONDARY AND CAPACITOR BUSES
DUE TO THE OPERATION OF THE OLTC ONE STEP UP

	At bus-1		At bus-9	
	$P_L = 0.4\text{pu}$	$P_L = 0.8\text{pu}$	$P_L = 0.4\text{pu}$	$P_L = 0.8\text{pu}$
Without DG	0.014	0.015	0.015	0.018
With DG, $P_{DG} = 1.5\text{ MW}$	0.015	0.017	0.017	0.02
With DG, $P_{DG} = 2.5\text{ MW}$	0.021	0.026	0.028	0.04

5.5.2 Local Voltage and Reactive Power Control

It has been explained in Section 3.5 that, in order to reduce the number of both OLTC and capacitor operations, the proposed time delay of the OLTC and capacitors are as follows, which is rewritten from equation (3-19)

$$td_{FC} < td_{SC} < td_{OLTC} \quad (5-7)$$

where td is the time delay; and subscript FC and SC indicates feeder capacitor and substation capacitor, respectively.

This time delay constraint given by equation (5-7) has been implemented and has worked properly in the case study presented in Chapter 3 (the case

without DG) and Chapter 4 (the case with synchronous machine DG). However, this time delay relation will not be applicable for the case with induction machine DG, as can be seen from the voltage change at bus-9 due to the switching of C_{F21} in Table 5.4. The switching of C_{F21} at bus-9 causes the voltage at that bus to change about 0.1 pu. This means that when the capacitor is switched off at 1.05 pu voltage (at bus-9), the voltage (at bus-9) will decrease to 0.95 pu, which is lower than U_{ON} of the capacitor (see Table 5.2). If the time delay of the feeder capacitor is shorter than the time delay of the OLTC, this will cause the feeder capacitor to be ‘hunting’ (repeatedly switch on and off). Therefore, the time delay operation of the OLTC and the capacitors for this particular case with DG is changed to be

$$td_{OLTC} < td_{FC} < td_{SC} \quad (5-8)$$

Another approach would be to change the size of the capacitor switched in one switching step, which is, however, not discussed here.

The OLTC and capacitor status with local control is shown in Figure 5.5, meanwhile the total daily operation of the OLTC and the capacitors presented in Table 5.6. The figure and the table indicate that the presence of the induction machine DG causes the OLTC to operate more frequently. This is because, for the dispatchable case, for the same load change, the voltage change increases when the DG in the system generates 2.5 MW (see Table 5.3). On the other hand, for the non-dispatchable case, the DG active and reactive power variation contributes to the voltage change. The increase of voltage change with the presence of the DG is also confirmed by the voltage fluctuation index shown in Figure 5.6.

Further, Figure 5.5 also shows that the duration of the feeder capacitors supplying reactive power is shorter with DG present in the system, although the presence of induction machine DG means that more reactive power is needed in the feeders. This is because the presence of the DG will mostly increase the voltage profile along the feeder, as can be concluded from the voltage at bus-1 and bus-10 in Figure 5.7. The increase of the voltage causes the feeder capacitors to easily reach their turn-off voltage U_{OFF} .

The voltage at the substation primary and secondary bus, as shown in Figure 5.7, indicates that the presence of DG does not interfere with the effectiveness of the OLTC operation, though the OLTC operates more frequently with the presence of DG. The substation secondary bus voltage is kept within 1.02 – 1.05 pu, according to the OLTC regulating range specified in Table 5.2.

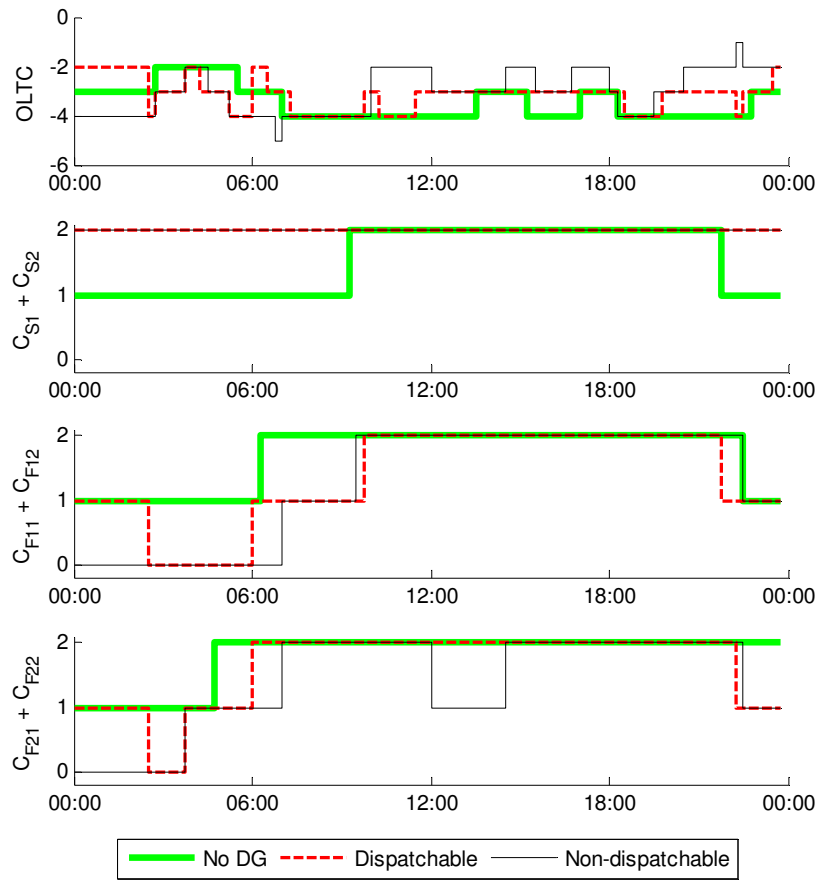

Figure 5.5. OLTC and capacitor status with local control.

TABLE 5.6
TOTAL DAILY OPERATION OF OLTC AND CAPACITORS WITH LOCAL CONTROL

Case	Total Number of Daily Operation			
	OLTC	$C_{S1}+C_{S2}$	$C_{F11}+C_{F12}$	$C_{F21}+C_{F22}$
No DG	8	2	2	2
Dispatchable	18	0	4	4
Non-dispatchable	18	0	4	6

The voltage at bus-10 shown in Figure 5.7 indicates that, in the system with DG, ensuring that the operation constraints are not violated for the worst operating conditions specified in Section 4.3 is not enough to keep the voltage

lower than the maximum allowed voltage U_{\max} all the time. This is because all feeder capacitors are off during maximum generation and minimum load. Therefore, overvoltage will not occur. But, when the load increases, some feeder capacitors will switch on, which can lead to an overvoltage. Though, $U_{\text{OFF}} < U_{\max}$ will ensure that the voltage at the capacitor bus does not exceed U_{\max} . However, there is also another source of voltage increase in the system that is not involved in the voltage control, e.g., the DG.

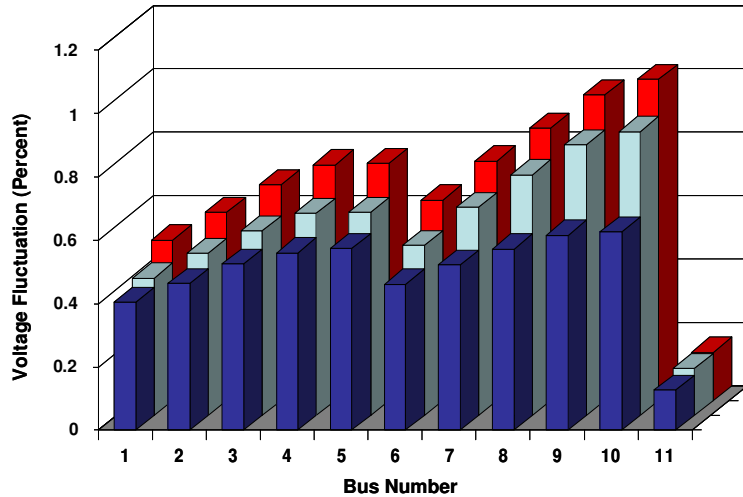

Figure 5.6. Voltage fluctuation index with local control. Front row: No DG, middle row: non-dispatchable, last row: dispatchable.

To mitigate the overvoltage, U_{OFF} can be decreased [42], or the DG has to reduce the power when the voltage at its terminal exceeds U_{\max} . However, in this particular case, decreasing U_{OFF} means that the feeder capacitor will be switched off when the capacitor is still expected to supply the reactive power, which obviously will increase losses. On the other hand, reducing the DG power means additional restriction of the DG power, from a certain DG size that has been allowed by the DNO according to the worst case scenario, which may imply additional cost. Another way of mitigating the overvoltage is by implementing remote (coordinated) voltage and reactive power control, which will be discussed in the following section.

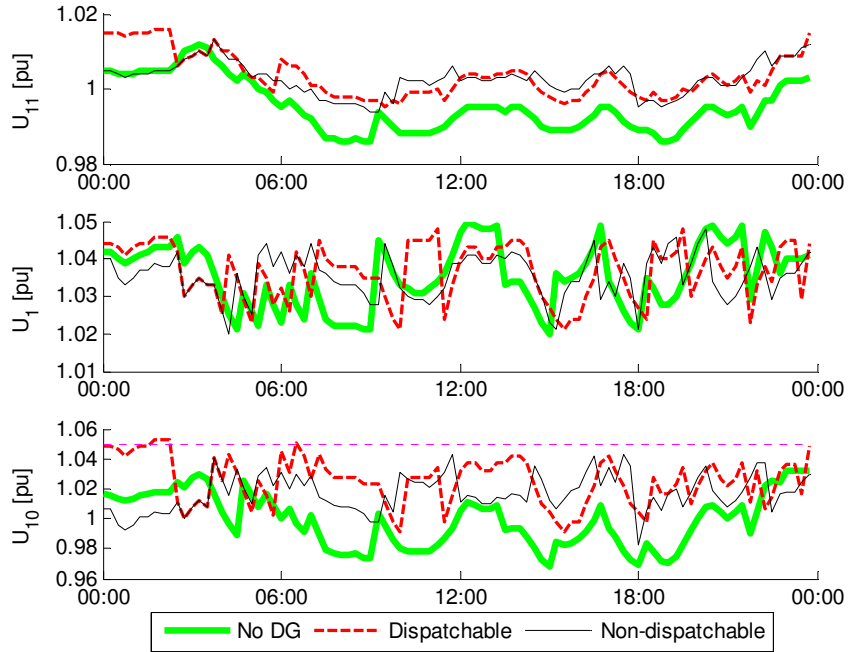

Figure 5.7. Voltage at some selected buses with local control.

5.5.3 Coordinated Voltage and Reactive Power Control

As has been explained in Section 5.4, the term of coordinated voltage and reactive power control refers to additional remote dispatch to the local control, in order to minimize distribution system losses, according to the forecasted load and DG output. It has also been explained in Chapter 4 that the losses can be decreased by optimizing the reactive power compensation and, for a system with constant power load, by operating the system at a higher voltage as long as the higher voltage does not cause the feeder capacitors to switch off.

It is shown in Table 5.5 that the OLTC operation one step up causes the substation secondary bus voltage to change around 0.015 pu for the case without DG, and around 0.025 pu for the case with dispatchable DG. With the OLTC deadband 0.03 pu as shown in Table 5.2, there will be two possible OLTC tap positions within the deadband for the case without DG and one possible OLTC tap position for the case with dispatchable DG. For the local

control, this means that the OLTC will operate more frequently with the presence of the induction machine DG, as has been presented in Table 5.6. For the coordinated control, this means that there is a possibility to decrease losses by operating the OLTC one tap lower for the case without DG, but not for the case with dispatchable DG. This is as shown in the remote dispatch schedule of the OLTC and the substation capacitors shown in Table 5.7.

TABLE 5.7
REMOTE DISPATCH SCHEDULE OF OLTC AND SUBSTATION CAPACITORS

	Without DG		With DG			
	Time	Action	Dispatchable		Non-dispatchable	
			Time	Action	Time	Action
1.	02.45	C_{S1} off	01.45	$U_{set}=1.0pu$	00.00	$U_{set}=1.0pu$
2.	06.15	TAP-1	04.45	$U_{set}=1.02pu$	04.00	$U_{set}=1.015pu$
3.	07.30	C_{S1} on	04.45	$U_{set}=1.035pu$	07.00	$U_{set}=1.035pu$
4.	10.15	TAP-1	21.45	$U_{set}=1.025pu$	09.00	TAP-1
5.	14.15	TAP-1	22.45	$U_{set}=1.015pu$	12.00	TAP+1
6.	17.15	TAP-1	-	-	15.00	TAP-1
7.	18.30	TAP-1	-	-	18.00	TAP-1
8.	-	-	-	-	22.30	$U_{set}=1.0pu$

Further, Table 5.7 indicates that loss minimization can be obtained by altering the OLTC set point U_{set} to a lower voltage for the cases with DG, but not for the case without DG. This is because the voltage at feeders with only load (without DG) tends to decrease towards the end of the feeder. Hence, a voltage at the feeder capacitor bus higher than U_{UB} of the OLTC means that the feeder capacitor excessively compensates the reactive power demand. Thus, $U_{set} + 0.5 DB = U_{max}$ and $U_{OFF} = U_{max}$ are optimal for loss minimization in the case without DG in the system. On the other hand, when there is DG in the system, the voltage along the feeder may increase, which causes the feeder capacitors to easily reach their turn-off voltage U_{OFF} when they are still expected to produce reactive power. Hence, the losses can be reduced if the feeder capacitors are kept supplying the reactive power by decreasing the voltage at the substation, e.g., by lowering U_{set} .

The OLTC and capacitor status with the coordinated control is shown in Figure 5.8, with the total daily operation of the OLTC and the capacitors presented in Table 5.8. The feeder capacitors are energized all the time for the cases with DG in this coordinated control in line with the increase of reactive power demand in the presence of the DG.

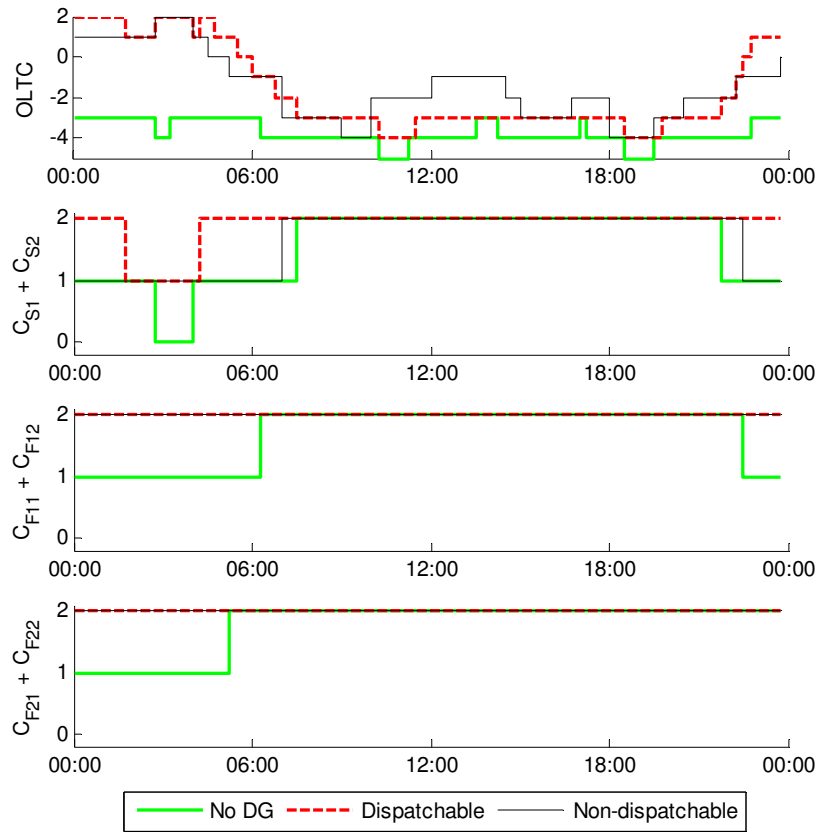

Figure 5.8. OLTC and capacitor status with the coordinated control.

Table 5.6 and Table 5.8 indicate that the number of daily OLTC operations with the coordinated control is 50% higher for the case without DG, does not change for the dispatchable case, and is 22% higher for the non-dispatchable case, compared to those with local control. Hence, the increase of the number of OLTC operations due to remote dispatch can be minimized by adjusting the OLTC control set point U_{set} instead of adjusting the OLTC tap position. Table 5.6 and Table 5.8 also show that coordinated control has a potential to decrease the number of capacitor operations.

Voltages at some selected buses and voltage fluctuations with the coordinated control are shown in Figure 5.9, with the voltage fluctuation index presented in Figure 5.10. It can be concluded from the voltage at bus-10 (the bus where the DG is connected), shown in Figure 5.9, that overvoltage

will not occur with the proposed coordinated control. Meanwhile, as previously explained, with local control, overvoltage occurs at bus-10. The presence of DG will, as in the case with local control, in general increase the voltage fluctuations in the system. However, the coordinated control lowers the increase of the voltage fluctuation due to the presence of DG, as can be concluded by comparing Figure 5.6 and Figure 5.10.

TABLE 5.8
TOTAL DAILY OPERATION OF OLTC AND CAPACITORS WITH
THE COORDINATED CONTROL

Case	Total Number of Daily Operation			
	OLTC	$C_{S1}+C_{S2}$	$C_{F11}+C_{F12}$	$C_{F21}+C_{F22}$
No DG	12	4	2	2
Dispatchable	18	2	0	0
Non-dispatchable	22	2	0	0

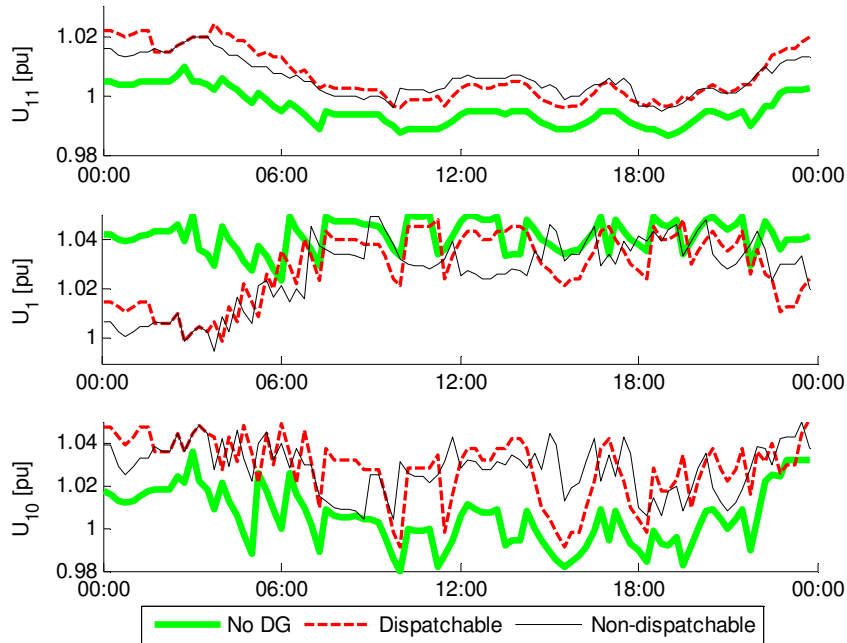

Figure 5.9. Voltage at some selected buses with the coordinated control.

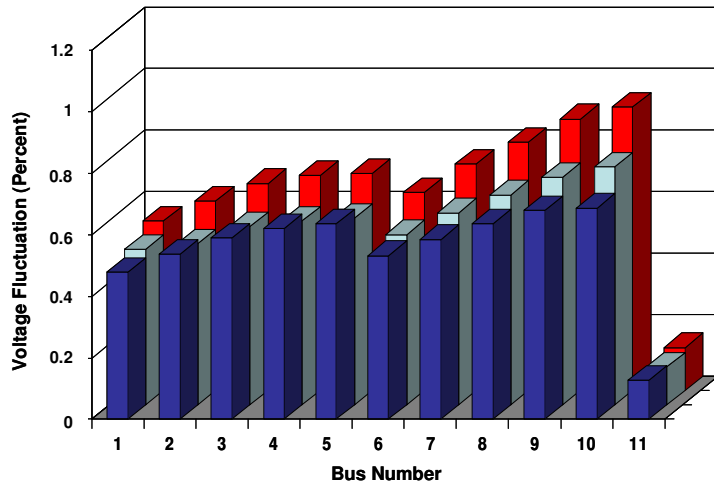

Figure 5.10. Voltage fluctuation index with local control. Front row: No DG, middle row: non-dispatchable, last row: dispatchable.

The effect of the coordinated control on the distribution system losses is shown in Figure 5.11, with the total daily losses comparison presented in Table 5.11. It is indicated that, the coordinated control always decreases the distribution system losses and the reduction will be more significant with the induction machine DG present. This is because the remote dispatch will decrease the losses significantly when the remote dispatch alters the capacitor configuration in the system. Meanwhile, it can be seen by comparing Figure 5.5 and Figure 5.8 that the daily capacitor configuration using coordinated control differs significantly from the one using local control for the cases with the DG. This is because, the OLTC set point close to U_{\max} is optimal for loss minimization for the system with constant power load without DG, but not with DG.

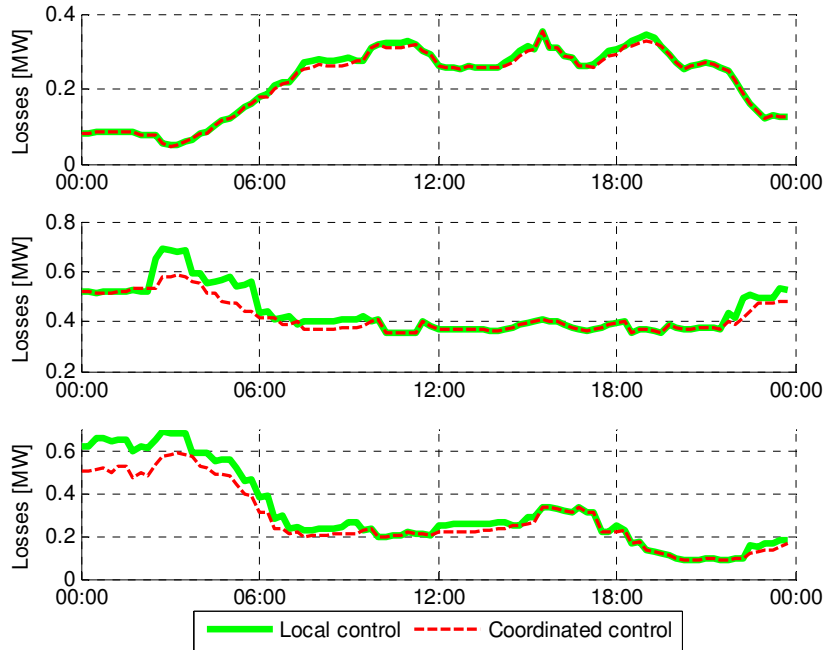

Figure 5.11. Losses with local control and with coordinated control. Upper plot: No DG, middle plot: dispatchable case, lower plot: non-dispatchable case.

TABLE 5.9
TOTAL DAILY DISTRIBUTION SYSTEM LOSSES WITH LOCAL CONTROL
AND WITH COORDINATED CONTROL

	Local Control (MWh)	Coordinated Control (MWh)	Percent Reduction
No DG	5.33	5.24	2%
Dispatchable	10.57	10.08	5%
Non-dispatchable	7.58	6.70	12%

5.6 Case Study with Synchronous Machine DG

The coordinated voltage and reactive power control in the presence of synchronous machine DG is tested on the same system as for the local voltage and reactive power control in Section 4.5. One line diagram of the test system is shown in Figure 4.3, where the specification of the system and the load profile are presented in Table 3.1 and Figure 3.7, respectively. Two cases are investigated; without DG involved in the voltage control (*unity pf* case) and with DG involved in the voltage control (*constant voltage* case). The OLTC and capacitor control set points shown in Table 4.2 are used. As explained in Chapter 4, these set points are resulted from an optimization for a given daily load.

The remote dispatch schedule is presented in Table 5.10. The losses for different cases with local control and with coordinated control are presented in Figure 5.12. For the unity pf case, in principle more loss reduction can be gained by executing more dispatch actions than the actions in Table 5.10. However, this will result in a significant increase of the number of OLTC operations.

Figure 5.12 shows that, in these cases, the loss reduction by the coordinated control is very marginal, since the control set points are already optimal for the given daily load. However, in practical systems, the daily load profile will change every day. Meanwhile with the local voltage and reactive power control method, the local control set points are kept unchanged for an extended period, on a seasonal basis for instance. Hence, in principle, more significant loss reduction, as in the cases with induction machine DG, can be expected.

TABLE 5.10
REMOTE DISPATCH SCHEDULE OF OLTC, SUBSTATION CAPACITORS AND DG

	Unity pf		Constant voltage			
	Time	Action	Time	Action		
		U_{set} [pu]		U_{set} [pu]	U_{DG1} [pu]	U_{DG2} [pu]
1.	10.00	1.025	07.30	-	-	1.045
2.	11.20	1.014	09.50	1.05	1.05	-
3.	19.00	1.025	12.00	1.0475	-	-
4.	19.40	1.014	14.30	1.05	-	-
5.	-	-	16.50	1.0475	1.0475	-
6.	-	-	17.40	1.05	1.05	-
7.	-	-	20.00	1.0475	1.0475	-
8.	-	-	22.00	-	-	1.04

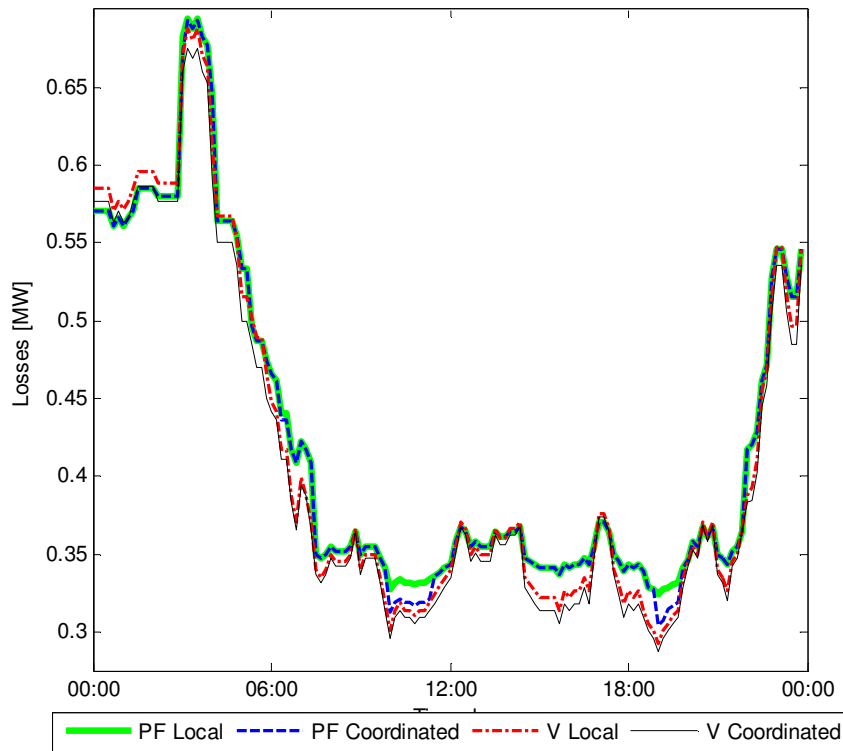

Figure 5.12. Losses for different cases with local and coordinated control. PF and V mean unity pf case and constant voltage case, respectively.

The maximization of the usage of capacitors with coordinated control in the constant voltage case can be seen in Figure 5.13. As has been explained, by the maximizing of the usage capacitor, the DG reactive power is expected to be reserved for emergency, which will improve the voltage stability of the system. The impact of DG on voltage stability will be discussed in Chapter 7.

The expense of the loss reduction with the coordinated control is the increased number of OLTC operations, which is shown in Figure 5.13 and Table 5.11. The same result has been shown for the cases with induction machine DG.

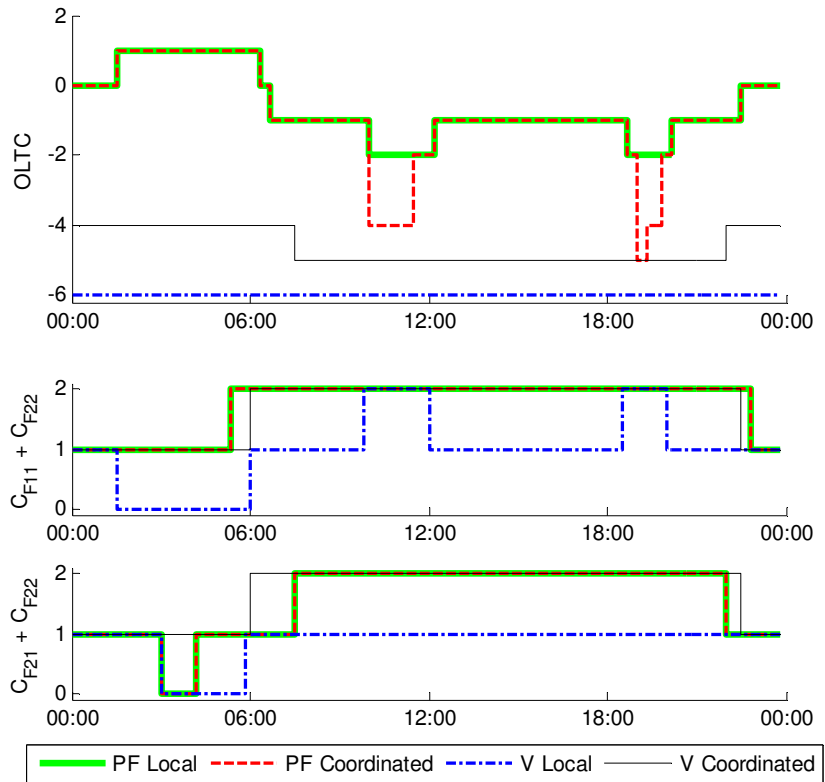

Figure 5.13. OLTC and capacitor status for different cases with local and coordinated control.

TABLE 5.11
TOTAL DISTRIBUTION SYSTEM LOSSES AND TOTAL NUMBER OF OLTC/CAPACITOR OPERATIONS IN A DAY WITH LOCAL AND COORDINATED CONTROL

		Losses [MWh]	Number of OLTC Operations	Total Number of Capacitor Operations
Unity pf	Local	10.29	8	6
	Coordinated	10.13	18	6
Constant voltage	Local	9.96	0	4
	Coordinated	9.79	2	8

5.7 Conclusions

In this chapter, coordinated voltage and reactive power control in the presence of DG is proposed and compared with the local voltage and reactive power control in Chapter 4. The coordinated control is based on automated remote adjustment of the locally operated voltage and reactive power equipment. The remote adjustment schedule is resulted from an optimization process for a one-day-ahead load forecast and a one-day to a few-hours-ahead DG power forecast.

DG with varying power output following the variation of the primary energy sources will obviously increase the voltage variation in the system. Moreover, the induction machine DG operated at a constant power is also potential to increase the voltage variation in the system, because the absorbed reactive power increases the voltage change due to the load change. The generated active power decreases the voltage change due to the load change. However, the X/R ratio of overhead lines is normally higher than 1 which may make the impact from the reactive power more dominant.

It has been demonstrated that the power flow reversal due to the DG will not interfere with the effectiveness of the OLTC operation, although the presence of induction machine DG increases the voltage variation in the system.

With the increase of the voltage variation in the presence of DG, keeping the voltage within the allowed limits all the time may not be possible if the voltage and reactive power control equipment are operated strictly locally. This can happen even though it has been ensured that the voltage limits will not be violated for the worst operating conditions. The risk of under/overvoltage can be minimized by using coordinated voltage and reactive power control, without unnecessarily restricting the DG size.

The optimum operating voltage that will minimize losses in the distribution system will move, following the load and DG output change. In this case, the proposed coordinated voltage and reactive power control is shown to be able to decrease losses, with the expense that it increases the number of OLTC operations.

Synchronous machine DG is capable to perform automatic voltage control. By involving the DG in the coordinated voltage control, the voltage control in the distribution systems will be similar to the one in the transmission systems, where the voltage control can be decomposed different hierarchical levels. It is shown that, by involving the DG in the coordinated voltage control, the reactive power from the available capacitors can be maximally used, considering that reactive power generated by capacitors is cheaper than generated by DG. The DG reactive power margins can also be reserved for emergency.

Chapter 6

Voltage Stability in Conventional Distribution Systems

This chapter presents voltage stability in conventional distribution systems. Reactive power transmission, different voltage instability mechanisms and the role of static and dynamic reactive power sources on different voltage instability mechanisms are investigated. The chapter starts with an overview of known results in order to bring the reader up to date. Then the case study will illustrate some of the important properties of the voltage stability concept in distribution systems without DG.

6.1 Introduction

Voltage and reactive power control in conventional distribution systems presented in Chapter 3 is intended for steady state voltage and reactive power control with economic system operation, e.g., to minimize losses in the system, as the objective function. The economic system operation is important during normal operating conditions. However, during emergency conditions, secure system operation is the first priority and the economic operation is of secondary importance [29].

Security of a power system relates to robustness of the system to imminent disturbances and, hence, depends on the system operating condition as well as on the contingent probability of disturbances [56]. One problem that has been recognized as important for secure system operation is power system stability. Many major blackouts caused by power system instability have illustrated the importance of this phenomenon.

Power system stability may be broadly defined as the property of a power system that enables it to remain in a state of operating equilibrium after being subjected to a disturbance [57]. Depending on the physical nature of the resulting mode of instability, power system stability can be classified into three categories: rotor angle stability, frequency stability and voltage stability.

Rotor angle stability refers to the ability of synchronous machines of an interconnected power system to remain in synchronism after being subjected to a disturbance. Instability that may result occurs in the form of increasing angular swings of some generators, leading to their loss of synchronism with other generators [56].

Frequency stability refers to the ability of a power system to maintain steady frequency following a severe system upset resulting in a significant imbalance between generation and load. Instability that may result occurs in the form of sustained frequency swings, leading to tripping of generating units and/or loads [56].

Voltage stability refers to the ability of a power system to maintain steady voltages at all buses in the system after being subjected to a disturbance from given initial operating conditions. Instability that may result occurs in the form of progressive fall or rise of voltages of some buses [56].

This thesis will only deal with voltage stability. The investigation will be focused on voltage and reactive power control in distribution systems to enhance voltage stability. It will start with an overview of active and reactive power transmission between two generators and between generator and load, and the importance of providing reactive power locally. Then an overview of different voltage instability mechanisms; transient voltage instability, long-term large-disturbance voltage instability and small-disturbance voltage instability; will follow. Regarding the importance of providing reactive power locally and the different voltage instability mechanisms, voltage and reactive power to improve voltage stability is then analyzed. The role of a dynamic reactive power source on transient voltage stability and a static reactive power source on long-term voltage stability will be shown. Finally, this chapter is ended with a study case to show different voltage instability mechanisms and the role of different reactive power sources in increasing voltage stability margins.

6.2 Active and Reactive Power Transmission

It has been widely known that, in power flow, active power is tightly coupled with the power angle while reactive power is related to the voltage magnitude. Further, increasing active power transmission between two remote buses can be obtained by increasing the power angle difference between the two buses. However, this analogy does not mean that the reactive power transmission between two remote buses can be increased by simply increasing

the voltage difference between the two buses, which will be presented hereafter.

6.2.1 Active and Reactive Power Transmission between Two Generators

To illustrate active and reactive power transmission between two generators, see the one line diagram of a two bus system with a short transmission line in Figure 6.1. The generators at both ends in this case represent a system with possible voltage support at both ends [1].

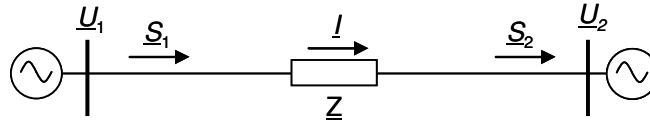

Figure 6.1. One line diagram to illustrate active and reactive power transfer between two generators with a short transmission line.

By defining

$$\begin{aligned}
 \underline{U}_1 &= U_1 e^{j\theta_1} \\
 \underline{U}_2 &= U_2 e^{j\theta_2} \\
 \theta_{12} &= \theta_1 - \theta_2 \\
 \underline{Z} &= R + jX = Z e^{j\varepsilon}
 \end{aligned} \tag{6-1}$$

where θ_{12} and ε are power angle and impedance angle respectively. The sending-end complex power will be

$$\begin{aligned}
 \underline{S}_1 &= \underline{U}_1 \underline{I}^* = \underline{U}_1 \left(\frac{\underline{U}_1 - \underline{U}_2}{\underline{Z}} \right)^* = \frac{U_1^2}{\underline{Z}^*} - \frac{\underline{U}_1 \underline{U}_2^*}{\underline{Z}^*} \\
 &= \frac{U_1^2}{Z} e^{j\varepsilon} - \frac{U_1 U_2}{Z} e^{j\varepsilon} e^{j\theta_{12}}
 \end{aligned} \tag{6-2}$$

Analogously, the receiving-end complex power will be

$$\underline{S}_2 = \underline{U}_2 \underline{I}^* = \underline{U}_2 \left(\frac{\underline{U}_1 - \underline{U}_2}{\underline{Z}} \right)^* = -\frac{U_2^2}{Z} e^{j\epsilon} + \frac{U_1 U_2}{Z} e^{j\epsilon} e^{-j\theta_{12}} \quad (6-3)$$

Hence, for a given line (Z fixed), the complex power at the sending-end and at the receiving-end depends on U_1 , U_2 and θ_{12} . By keeping U_1 , U_2 and Z constant, the following equations will be obtained

$$\underline{S}_1 = C_1 - B e^{j\theta_{12}} \quad (6-4)$$

$$\underline{S}_2 = C_2 + B e^{-j\theta_{12}} \quad (6-5)$$

where

$$C_1 = \frac{U_1^2}{Z} e^{j\epsilon}$$

$$C_2 = -\frac{U_2^2}{Z} e^{j\epsilon}$$

$$B = \frac{U_1 U_2}{Z} e^{j\epsilon}$$

By varying θ_{12} , \underline{S}_1 and \underline{S}_2 will be circles in the complex plane, which are called as the *sending-end power circle* and the *receiving-end power circle* [1]. The centers of the sending-end and receiving-end power circles are C_1 and C_2 , respectively. Both circles have the same radius B .

For example, assume that the line impedance for the system in Figure 6.1 is $Z = 0.2$ pu with $X/R = 5$, and the sending-end voltage is kept at 1.00 pu. The power circles with the receiving-end voltage 0.95 and 0.90 pu are shown in Figure 6.2 and Figure 6.3, respectively. The figures indicate that:

1. Increasing θ_{12} will increase the active power sent and received. There is a limit for the active power received, e.g, for $\theta_{12} = \epsilon$.
2. Increasing θ_{12} further will increase active power transfer further. However, at very high active power transfer, the reactive power required at both sending-end and receiving-end is very high. It is shown that, at high power angles, the curves become steep, which means that more than one megavar is required for each additional megawatt transmitted.

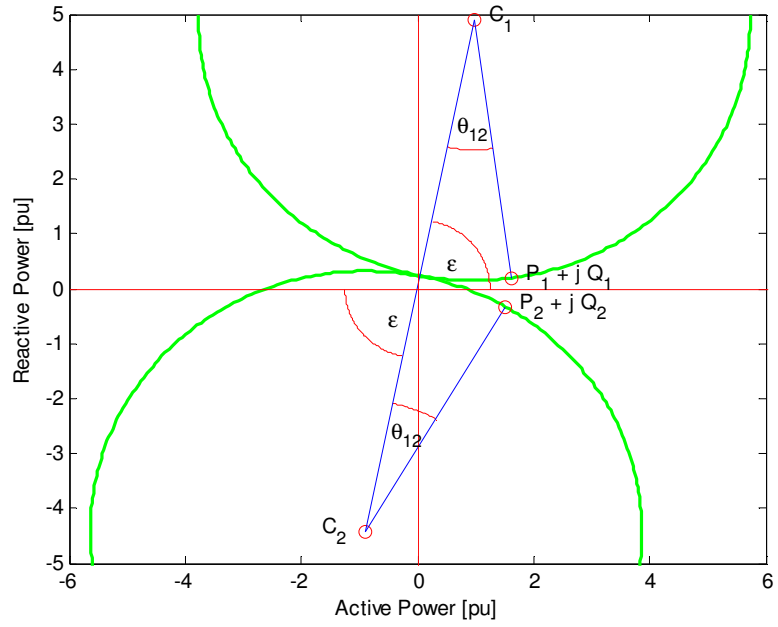

Figure 6.2. Power circle diagram with receiving-end voltage 0.95 pu.

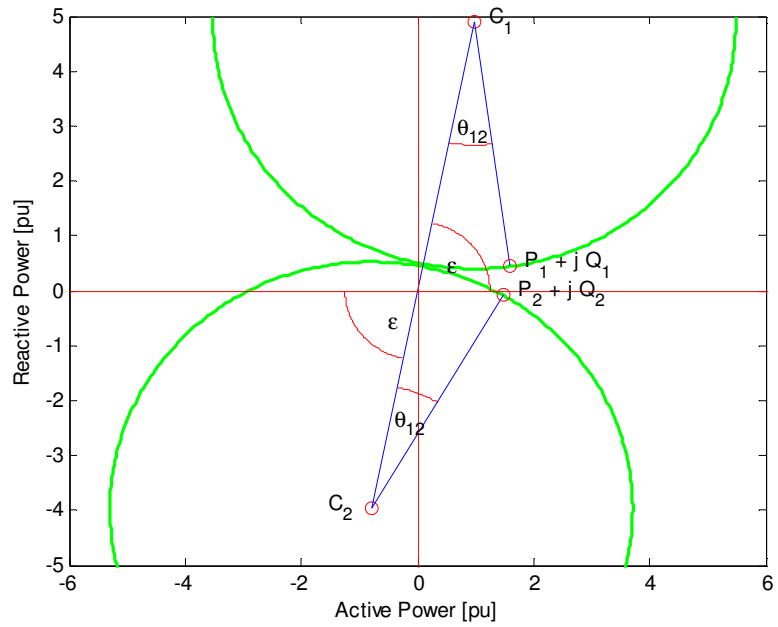

Figure 6.3. Power circle diagram with receiving-end voltage 0.90 pu.

Hence, it can be concluded that contrasted with active power transfer, the reactive power simply cannot be transmitted over long distances, even with substantial voltage magnitude gradients [29]. Reactive power has to be provided locally rather than attempted to be supplied over a long distance.

Now consider that the line is modelled as a long transmission line, as the one shown in Figure 6.4.

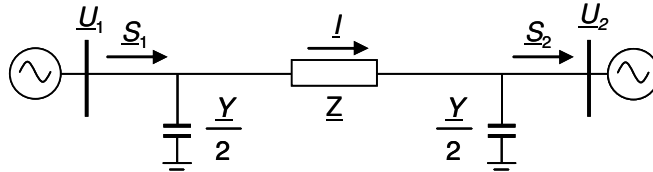

Figure 6.4. One line diagram to illustrate active and reactive power transfer between two generators with a long transmission line.

The sending-end and receiving-end complex power can then be obtained by adding the complex power contribution from the shunt capacitors to equation (6-4) and (6-5), respectively, which can be written as

$$\underline{S}_1 = C_1 - B e^{j\theta_2} \quad (6-6)$$

$$\underline{S}_2 = C_2 + B e^{-j\theta_2} \quad (6-7)$$

where

$$C_1 = \frac{Y}{2} e^{-j\pi/2} U_1^2 + \frac{U_1^2}{Z} e^{j\epsilon}$$

$$C_2 = -\frac{Y}{2} e^{-j\pi/2} U_2^2 - \frac{U_2^2}{Z} e^{j\epsilon}$$

$$B = \frac{U_1 U_2}{Z} e^{j\epsilon}$$

with $\underline{Y} \approx Y e^{j\pi/2}$ the line shunt admittance.

Based on the similarity of the sending-end and the receiving-end power transmission in a short line and in a long line shown above, only the short line model will be presented for an overview of the active and reactive power transmission from generator to load in the subsection hereafter.

6.2.2 Active and Reactive Power Transmission from Generator to Load

To illustrate active and reactive power transmission from generator to load, see the one line diagram of a two bus system in Figure 6.5.

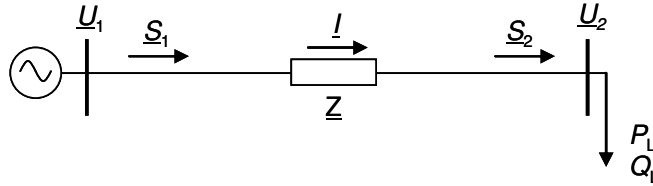

Figure 6.5. One line diagram to illustrate active and reactive power transfer from generator to load.

The current through the line and the line impedance can be written as

$$I = \frac{S_1}{U_1} = \frac{S_2}{U_2} \quad (6-8)$$

$$\underline{Z} = R + jX \quad (6-9)$$

The sending-end power is the summation of the receiving-end power and the losses in the line, which can be written

$$\underline{S}_1 = P_1 + jQ_1 = (P_2 + I^2 R) + j(Q_2 + I^2 X) \quad (6-10)$$

Where the receiving-end power is the load power, or

$$\underline{S}_2 = P_2 + jQ_2 = P_L + jQ_L \quad (6-11)$$

From Equations (6-8) and (6-10), the square of the sending-end power can be written as

$$S_1^2 = \left(P_2 + R \cdot \left(\frac{S_2}{U_2} \right)^2 \right)^2 + \left(Q_2 + X \cdot \left(\frac{S_2}{U_2} \right)^2 \right)^2 \quad (6-12)$$

From Equations (6-8) and (6-12), the following fourth-order equation can be derived

$$A \left(\left(\frac{|S_2|}{|U_2|} \right)^2 \right)^2 + B \left(\frac{|S_2|}{|U_2|} \right)^2 + C = 0 \quad (6-13)$$

where

$$A = R^2 + X^2$$

$$B = 2RP_2 + 2XQ_2 - U_1^2$$

$$C = P_2^2 + Q_2^2$$

For a given sending-end voltage U_1 and line impedance Z , the receiving-end voltage as a function of the receiving-end (load) power can then be obtained by using equation (6-13).

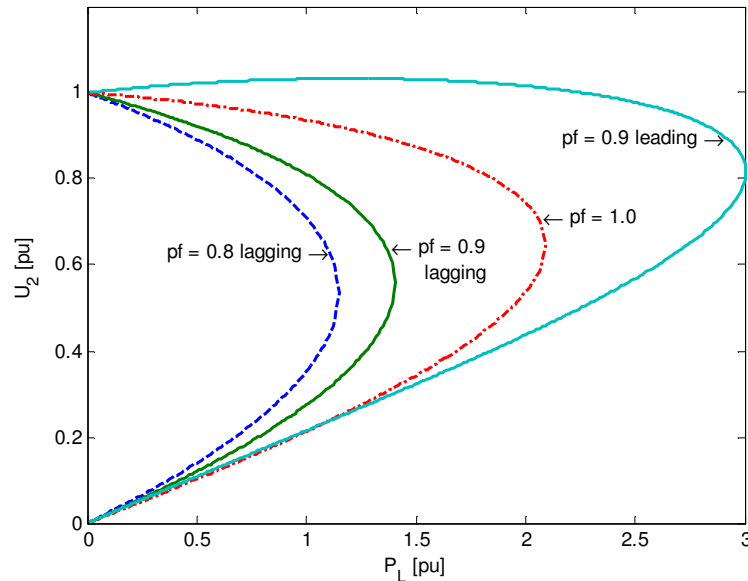

Figure 6.6. Load bus voltage as a function of load power (*PV curve*^{*}).

For example, assume that the line impedance for the system in Figure 6.5 is $Z = 0.2$ pu with $X/R = 5$, and the sending-end voltage is kept at 1.00 pu.

^{*} Though the voltage is notated as U in this thesis, *PV curve* is used instead of *PU curve*, as *PV curve* has been widely known and used in many references.

These quantities are the same as the ones used for example in Section 6.2.1. The load bus voltage as a function of load power (which is normally called the *PV curve* [29]) for this system is shown in Figure 6.6. The figure indicates that the power transfer (from the generator to the load) can be increased by improving the power factor of the load. Again, as in the case of power transfer between two generators in Section 6.2.1, this emphasizes the importance of providing reactive power locally rather than attempting to supply it from a long distance.

6.3 Voltage Stability

Sometimes the distinction between voltage instability and rotor angle instability is not clear, as aspects of both phenomena may exist. They can go hand in hand and it can be questioned whether voltage collapse (voltage instability) causes loss of synchronism (rotor angle instability), or loss of synchronism causes voltage collapse.

Nevertheless, voltage stability has been receiving special attention in many power systems, especially in weak power systems with long lines and heavy loads. Voltage stability is considered as the cause of recent blackouts such as the one in North America on August 14, 2003, and the one in southern Sweden on September 23, 2003 [58].

6.3.1 Definitions

Below some terms and definitions related to voltage stability according to CIGRE [59] are listed:

“A power system at a given operating stage and subject to a given disturbance is *voltage stable* if voltages near loads approach post-disturbance equilibrium values. The disturbed state is within the region of attraction of the stable post-disturbance equilibrium”.

“A power system at a given operating state and subject to a given disturbance undergoes *voltage collapse* if post-disturbance equilibrium voltages are below acceptable limits. Voltage collapse may be total (blackout) or partial”.

“Voltage instability is the absence of voltage stability, and results in progressive voltage decrease (or increase)”.

6.3.2 Time Frames and Mechanisms of Voltage Stability

The dynamics of voltage instability and collapse can range from a fraction of a second to tens of minutes. This is exemplified from voltage stability phenomena and time responses for various power system components shown in Figure 6.7. Among those phenomena, there are some typical voltage stability mechanisms [29],[57], which will be explained below.

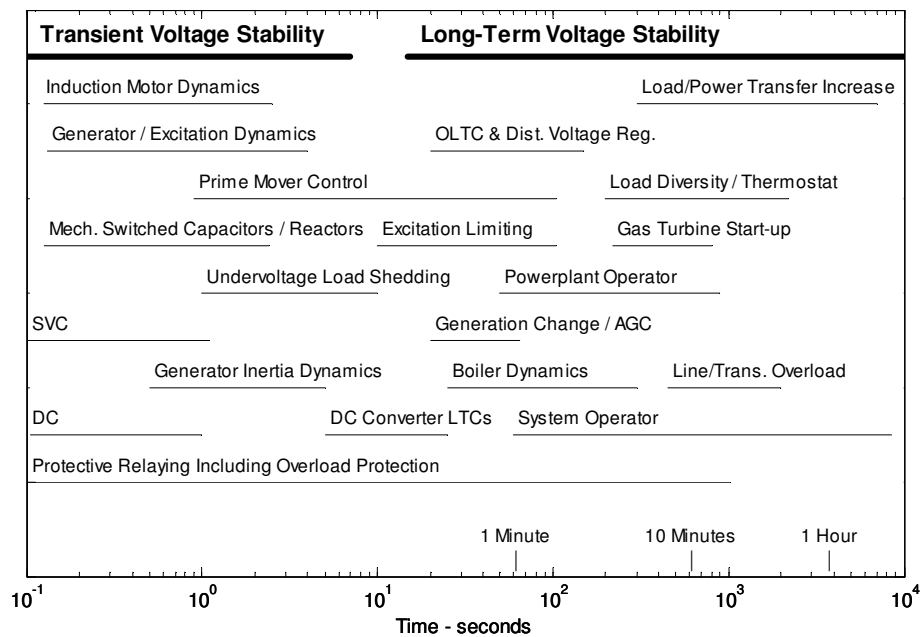

Figure 6.7. Voltage stability phenomena and time responses, rewritten from [29].

Transient Voltage Stability

Transient voltage stability involves fast acting load components like induction motors, with the time frame from fractions of a second to a few seconds as shown in Figure 6.7. This time frame is similar as for transient rotor angle stability.

To analyze the stability of an induction motor consider the torque speed plot of an induction motor shown in Figure 6.8. Assume a three-phase fault at the motor terminal, which brings the motor terminal voltage to zero. Before the fault, the electrical torque τ_E and the mechanical torque τ_M are equal. With the electrical transient during a fault neglected, immediately after the fault occurs, the electrical torque goes to zero. So, the motor will decelerate, according to the following equation of motion [57]

$$2H \frac{d\omega}{dt} = \tau_E - \tau_M \quad (6-14)$$

where H and ω are the inertia in MWs/MVA and speed in rad/s, respectively, and τ_E and τ_M are in pu.

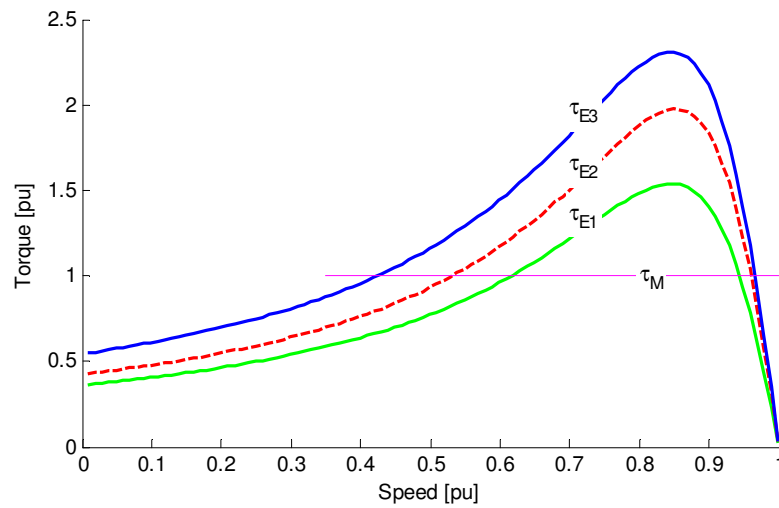

Figure 6.8. Torque slip (speed) plot of an induction motor.

For simplicity, assume that τ_M is constant during the fault. The motor will be able to reaccelerate back to its equilibrium operating speed as long as τ_E is higher than τ_M or when ω is higher than the critical speed ω_{CR} when the fault is cleared. Hence, the stability can be increased by increasing the electrical torque of the motor.

To get an overview on how to increase the electrical torque of the motor, see the equivalent diagram of an induction machine in Figure 6.9, where subscript S , R and M indicate stator, rotor and magnetization, respectively, and notation s indicates slip [57]. The torque slip equation can be derived from the figure as

$$\tau_E = \frac{r_R}{s} i_R^2 = \frac{r_R}{s} \frac{U_E^2}{\left(r_E + \frac{r_R}{s}\right)^2 + (x_E + x_R)^2} \quad (6-15)$$

and the reactive power absorbed by the motor

$$Q_E = i_R^2 (x_E + x_R) = \frac{U_E^2 (x_E + x_R)}{\left(r_E + \frac{r_R}{s}\right)^2 + (x_E + x_R)^2} \quad (6-16)$$

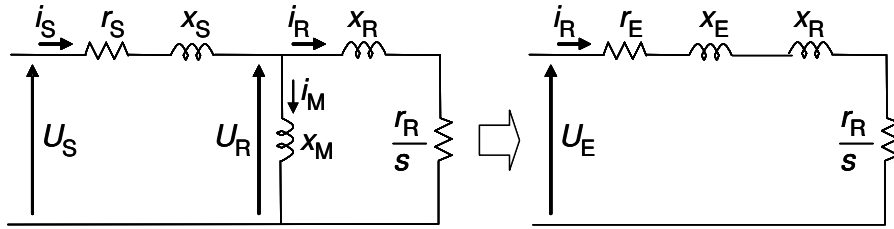

Figure 6.9. Equivalent diagram of an induction machine. Left: stator rotor equivalent, right: equivalent suitable for torque slip analysis.

Equation (6-15) indicates that the motor electrical torque can be increased by increasing the motor terminal voltage and equation (6-16) indicates that the motor reactive power demand increases with the increase of the slip (decrease of the speed). The increase of reactive power demand will decrease the motor terminal voltage, which, by assuming the active power constant, can be derived as

$$\frac{\Delta U_S}{U_S} \approx -\frac{\Delta Q_E}{S_{SC}} \quad (6-17)$$

where S_{SC} is the short circuit capacity of the grid.

The decrease of the motor terminal voltage will further decrease the motor electrical torque (see equation (6-15) and the motor equivalent diagram in Figure 6.9).

If the electrical torque of the motor is lower than the mechanical torque when the fault is cleared, the motor will continuously decelerate and stall. This will increase the motor reactive power consumption. A large amount of reactive power consumed by the motor will not only decrease the motor terminal voltage, but will also depress the voltages nearby the motor. This

causes other motors to stall and may lead to a voltage collapse in the power system.

Long-Term Large-Disturbance Voltage Stability

This kind of voltage stability involves high loads, high power imports from remote generation and a sudden large disturbance [29].

For an overview of long-term large-disturbance voltage stability, consider a one line diagram of a load (which is a simplification of a distribution system) fed from a long transmission corridor with three lines and a HV/MV transformer with an OLTC, as shown in Figure 6.10. The OLTC keeps U_2 within a certain range with a certain time delay, as explained in Chapter 3.

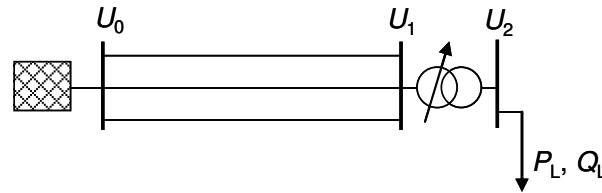

Figure 6.10. One line diagram of a transmission system for long-term large-disturbance voltage stability analysis.

Now assume that faults occur at the transmission corridor and two of the lines permanently open due to the faults. The system is still stable at the instance after the fault clearance. The disconnection of the lines cause the voltages U_1 and U_2 to decrease due to the significant increase of the impedance and the significant decrease of the line capacitive charging in the transmission system. The power of the voltage dependent load will basically also decrease with the decrease of U_2 , which causes U_2 to slightly increase, but this voltage increase is much less compared to the previously mentioned voltage decrease.

The decrease of U_2 will be responded by the OLTC by changing its tap position in order to increase U_2 back to within the OLTC deadband. The power of the voltage dependent load will increase with the increase of U_2 , which will decrease U_1 further. The more the OLTC operates, the more the load increases and the more U_1 decreases. Further, the increase of load, the increase of line impedance and the decrease of line capacitive charging increase reactive power losses. The large reactive power losses must be supplied from the remote grid. As has been shown in Section 6.2, this is ineffective. The remote grid can no longer support the load and the reactive

power losses and the voltage will decay rapidly. Partial or complete voltage collapse will then follow.

The final stages may involve induction motor stalling and distance relay operation, especially distance relay zone-3. The motor stalling mechanism has previously been explained. The distance relay operation is triggered by the drop of voltage and the increase of current. This causes the impedance seen by the relay, which is the voltage divided by the current, to decrease. Thus the relay may enter the relay zone-3 operation.

Long-Term Small-Disturbance Voltage Stability

The basic processes contributing to small-disturbance voltage instability are essentially of a steady state nature, such as very large load buildup or large rapid power transfer increase. Static analysis, using the PV curve that has been explained in Section 6.2.2, can be effectively used to determine stability margins [29],[57].

Since the instability builds up during a considerably long period, operator actions, such as timely support of reactive power equipment or load shedding, may be necessary to prevent the instability. A small-disturbance will be the trigger of the instability. The final stages of instability involve actions of faster equipment such as described in the transient and long-term large-disturbance voltage stability [29].

6.4 Voltage and Reactive Power Control in Distribution Systems with Voltage Stability Consideration

The system for the case study in Chapter 3 is designed to investigate a steady state voltage and reactive power control, with loss minimization as the objective function. In that system, the available capacitors are economically designed to compensate the steady state reactive power demand, as can be seen in Figure 3.9 and Figure 3.10 where all shunt capacitors in the substation are energized on maximum load.

With all shunt capacitors energized, the only way to restore the substation secondary voltage due to the tripping of the upstream transmission line is by operation of the OLTC. On the other hand, as has been explained in Section 6.3.2, this may lead to voltage instability. This problem can be

mitigated for example by installing additional mechanically switched shunt capacitors in the substation and coordinate the operation of these capacitors with the operation of the OLTC. By this coordination, instead of operating the OLTC, the capacitors will be switched on when the disturbance causes the voltage at both sides of the transformer to decrease to a certain value. Correspondingly, the capacitors will be switched off when the disturbance makes the voltage at both sides of the transformer to increase to a certain value.

The coordination between mechanically switched shunt capacitors and OLTC will help in increasing the long-term voltage stability margin. However, the operation of the mechanically switched shunt capacitors is too slow to mitigate transient voltage instability, such as induction motor stalling. In this case, voltage and reactive power devices with dynamic response, such as static var compensator (SVC) or static synchronous compensator (STATCOM) are needed [60].

SVC and STATCOM have inherent capability to provide both dynamic reactive power compensation for transient voltage stability improvement and steady state voltage regulation [61]-[62]. An SVC consists of a combination of a fixed capacitor, thyristor-switched capacitors and a thyristor-controlled reactor, which are normally connected through a transformer to the grid. The SVC power circuit is principally shown in Figure 6.11. A STATCOM is a voltage source converter connected through an inductance to the grid, which is principally depicted in Figure 6.12(a), where the STATCOM consist of a DC capacitor, a converter and a step up transformer [63].

The analysis in this chapter will focus on STATCOM. However, the analysis is also valid for an SVC by taking into account that the reactive power generated by a STATCOM is linearly proportional to the voltage ($Q_{\text{STATCOM}} \sim U_{\text{STATCOM}}$), meanwhile the reactive power generated by an SVC is linearly proportional to the square of the voltage ($Q_{\text{SVC}} \sim U_{\text{SVC}}^2$).

6.4.1 The Principle of STATCOM Operation

The principle of STATCOM operation is illustrated in Figure 6.12.(b) and Figure 6.12.(c). The STATCOM exchange reactive power with the grid. The exchange of reactive power between the converter and the grid can be varied by the amplitude of the three-phase STATCOM voltage (U_{STATCOM}). If U_{STATCOM} is increased higher than the grid voltage, U_{Grid} , the converter generates capacitive-reactive power for the grid. If U_{STATCOM} is decreased lower than U_{Grid} , the converter absorbs inductive-reactive power from the grid.

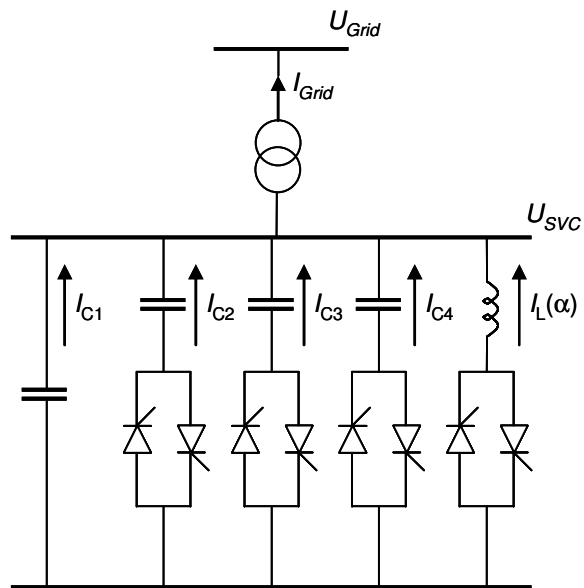

Figure 6.11. The SVC principle power diagram.

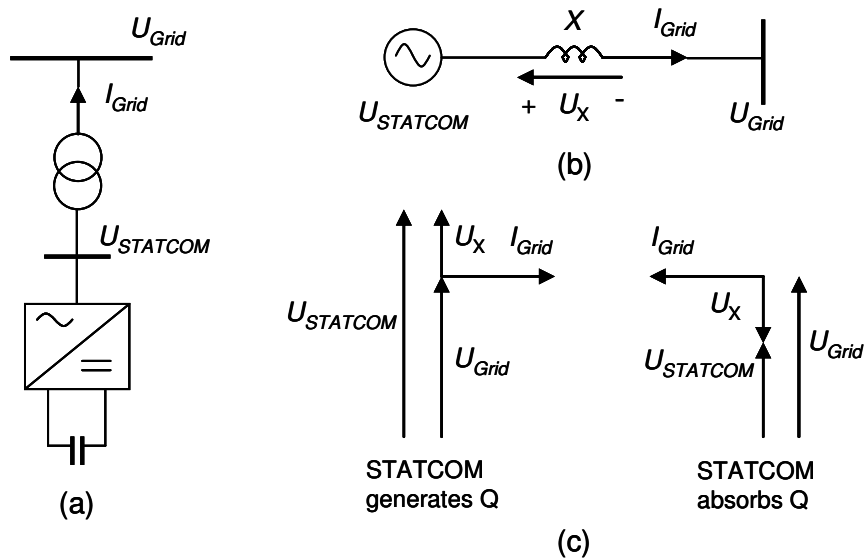

Figure 6.12. The STATCOM principle diagram: (a) power circuit; (b) equivalent diagram; (c) power exchange operation.

6.4.2 Coordination between STATCOM/SVC and OLTC

The installation of a STATCOM at a substation has to be coordinated with the available substation voltage and reactive power control equipment, e.g., OLTC and mechanically switched capacitors, especially for the steady state voltage and reactive power control, in order to get the maximum benefit from the STATCOM installation. This is because a STATCOM provides continuous control with a rapid response. On the other hand, the OLTC and the capacitor control the bus voltage and the reactive power in a stepwise manner with much longer time delays. If the STATCOM is not coordinated with the OLTC and the capacitor, the OLTC and the capacitor will be unable to participate in controlling the voltage and the reactive power, except when the STATCOM has reached its limit. When the STATCOM reaches its limit, it will lose its capability to dynamically control the voltage or reactive power flow during an emergency.

Different methods have been presented to coordinate the SVC/STATCOM with the OLTC and the shunt capacitors in a substation. The basic concept of the coordination between STATCOM, OLTC and capacitor devices is presented in [40] as shown in Figure 6.13. The capacitor is switched to regulate the substation primary voltage and reactive power flow through the transformer, meanwhile the OLTC regulates the substation secondary voltage. The OLTC operation is restricted by the state of the STATCOM. It is shown in [40] that adding a STATCOM to the substation voltage and reactive power control will decrease the number of OLTC operations and the voltage fluctuation.

In [64], line drop compensation is implemented in the SVC and OLTC coordination. The SVC controls the load centre voltage, according to the line drop compensation principle, while the OLTC controls the substation secondary bus voltage. Similar to the one in [40], the information from the SVC is sent to the OLTC. This information is then used by the OLTC to adaptively change its time delay operation.

In [65], the SVC deadband is set larger than the OLTC deadband. By using this coordination, neither the OLTC nor the SVC will operate for a voltage variation within the OLTC deadband. If the voltage exceeds the OLTC deadband (but is still within the SVC deadband) for a time longer than the OLTC time delay, the OLTC will firstly operate to bring the voltage back within the OLTC deadband, and then the SVC will dynamically make an adjustment. If the voltage goes outside the SVC deadband, the SVC will dynamically operate to bring the voltage back to the OLTC deadband. The drawback of this method is that the number of OLTC operations and the

voltage fluctuation will increase, compared to the results that can be achieved by the method in [40]. Meanwhile, the benefit is that the SVC reactive power reserve can be maximized for emergency.

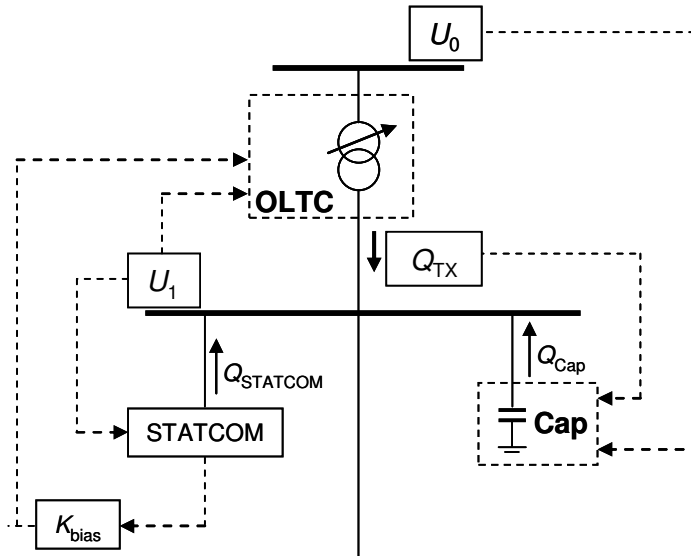

Figure 6.13. Conceptual diagram of coordination between STATCOM, OLTC and capacitors in [40].

The STATCOM utilization in this chapter, as well as in the next chapter, will be focused on dynamic voltage and reactive power control, where the OLTC and the mechanically switched capacitor are not fast enough to respond to a disturbance. It is assumed that in steady state the STATCOM has been properly coordinated with the OLTC and the capacitor in such a way that the usage of reactive power from the mechanically switched capacitor is maximized. Thereby the STATCOM got enough margins to dynamically respond to a disturbance.

6.4.3 Modelling of STATCOM for Dynamic Simulation

The dynamic simulations in this chapter, as well as in the next chapter, are performed on DIgSILENT PowerFactory® [66]. A one line diagram of the STATCOM is shown in Figure 6.14. The STATCOM consists of a DC capacitor that keeps the DC voltage constant, a PWM converter that generates

the AC voltage and a step-up transformer. The STATCOM can be set to operate at a constant voltage or at a constant reactive power. The DC bus voltage will always be kept constant.

The STATCOM control for dynamic simulation is shown in Figure 6.15. The converter gets the current reference from the VDC/VAC-Controller and the phase reference from a phase measurement device PLL (phase-locked loop). In order to keep the DC voltage, the AC voltage and the reactive power output constant, the controller gets its input from the DC, AC and reactive power measurement, respectively. The controller basically consists of a PI controller and current limiters.

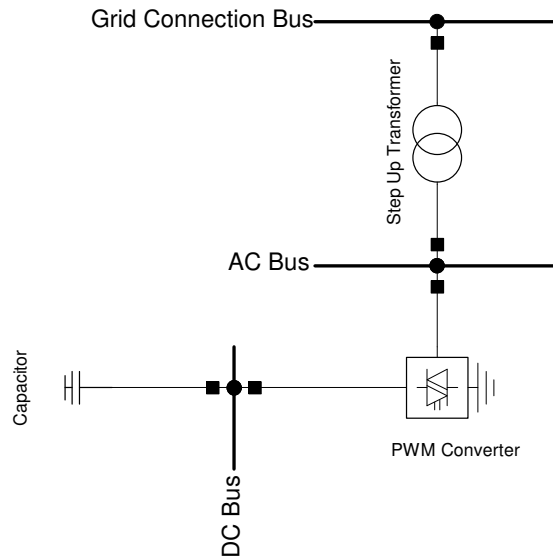

Figure 6.14. One line diagram of STATCOM in DIgSILENT.

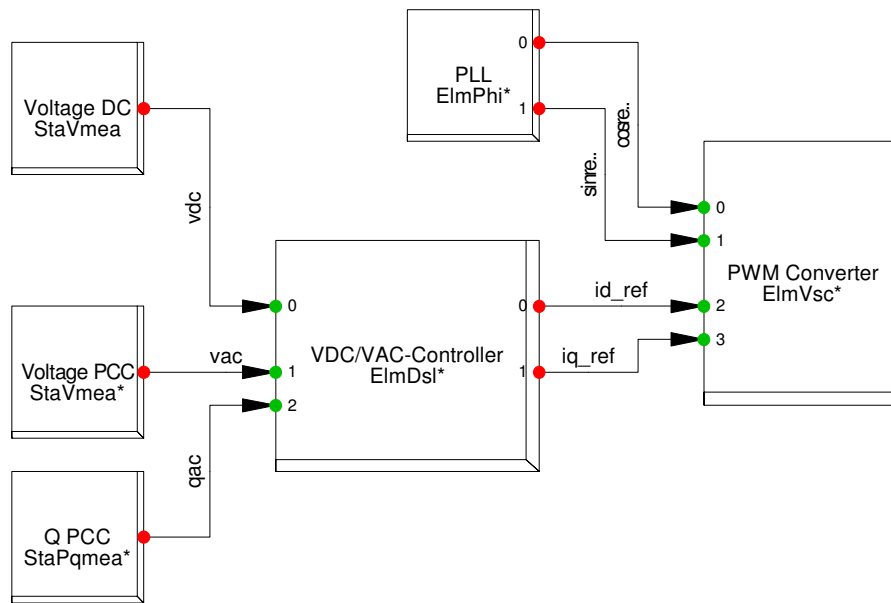

Figure 6.15. Block diagram of the STATCOM control.

6.5 Case Study

The system for the case study is shown in Figure 6.16. There are two substations with their 11 kV distribution systems fed from a 66 kV grid. “*System-1*” is a substation and a distribution system fed from bus-101, where the distribution system consists of three feeders, with one of the feeders dedicated to supply two induction motors. The capacitors at the feeder-ends are mainly aimed to provide voltage support to the feeders, the capacitors at the motor terminals are meant to compensate the motor reactive power demand and the aim of the capacitor at the substation is mainly for loss reduction. “*System-2*” is a substation and a distribution system fed from bus-102, where the distribution system is simplified into one bus.

Depending on the type of stability investigated, STATCOM or additional shunt capacitors will be installed at the substation secondary bus to improve the voltage stability of the system. The detailed specification of the system under study is presented in Table 6.1. The available capacitors are already optimum to minimize losses in such a way that, on nominal load, all capacitors are energized, similar to the case studies presented in Chapter 3.

Nominal loads are chosen in all simulations, as it will result in the worst case condition.

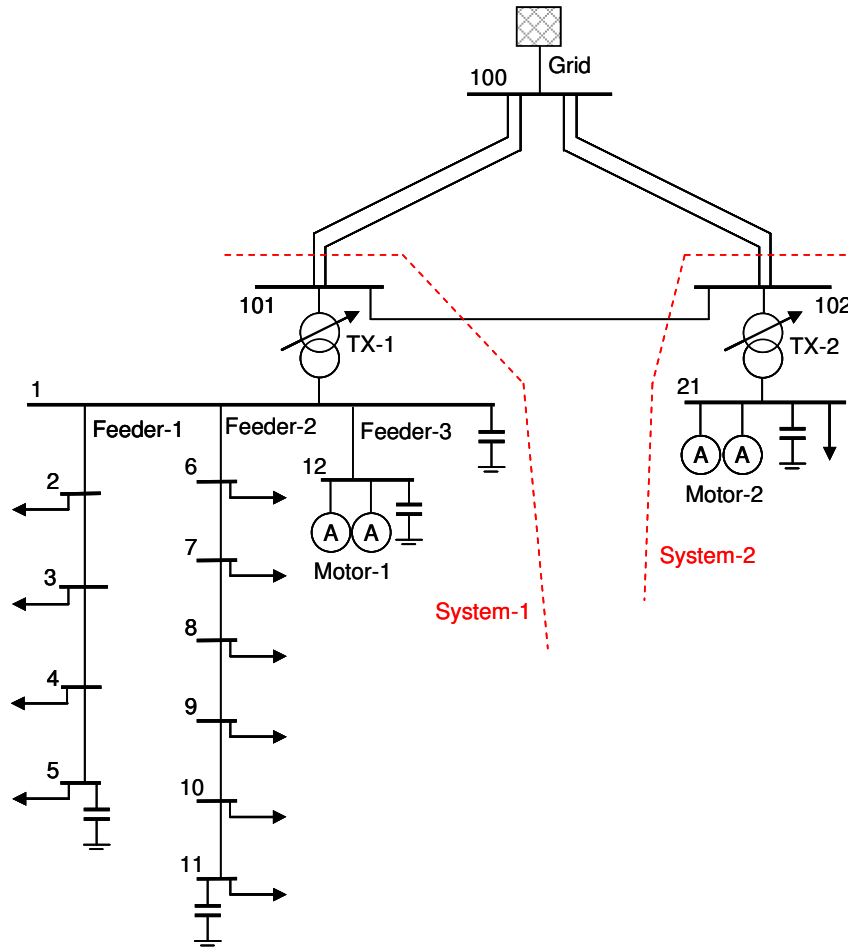

Figure 6.16. One line diagram of the system under study.

TABLE 6.1
SPECIFICATIONS OF THE TEST SYSTEM

Grid	$S_{SC} = 2500$ MVA, $x/r = 10$, operating voltage $U_{Grid} = 1.02$ pu.
Transmission lines	$r = 0.15$ Ω /km, $x = 0.4$ Ω /km, $b = 2$ μ mho/km, with the following lengths: Line 100-101 : 80 km Line 101-102 : 30 km Line 100-102 : 80 km
Distribution lines	$r = 0.12$ Ω /km, $x = 0.35$ Ω /km, where the distances between two buses are 1.5, 1.2 and 1 km for feeder-1, feeder-2 and feeder-3, respectively.
Loads	At bus-102: 20 MW and 5 Mvar. Under Feeder-1: 2.2 MW at each bus, with 0.85 pf. Under Feeder-2: 1.4 MW at each bus, with 0.85 pf. Voltage dependence factor of the loads is $\alpha = \beta = 1.6$, except otherwise specified (see Equations (3-20) and (3-21) for the definition of α and β).
Transformers	66/11 kV, 30 MVA, $x = 10\%$, $x/r = 10$, OLTC at HV side, -10% to +10% regulation with 10 steps. The OLTC is set to keep the substation secondary voltage within 1.01 ± 0.01 pu with constant time delay 40s.
Capacitors	1.5 Mvar at each feeder-end, 8 Mvar at each substation secondary bus and 2 Mvar at bus 12.
Induction motors	3300 kW, 11 kV, 0.88 pf, $x_R = 0.178$ pu, $x_R/r_R = 10$.

6.5.1 Transient Voltage Stability

The investigation of transient voltage stability is intended to observe how the system becomes transiently unstable and how to mitigate the problem by the installation of a STATCOM. For example, a bolted three-phase fault is applied in the middle of line 101-102 and cleared at 0.35s.

The motors in System-1 (Motor-1) are becoming unstable, meanwhile Motor-2 (at bus-21) is remaining stable. A 5 MVA STATCOM is then installed at bus-1 (the substation secondary voltage of System-1), with the specifications given in Table 6.2. With the STATCOM installation, all motors become stable. This can be concluded from the substation voltages, motor terminal voltages, motor reactive power demand and motor torque-speed curves shown in Figure 6.17 - Figure 6.18.

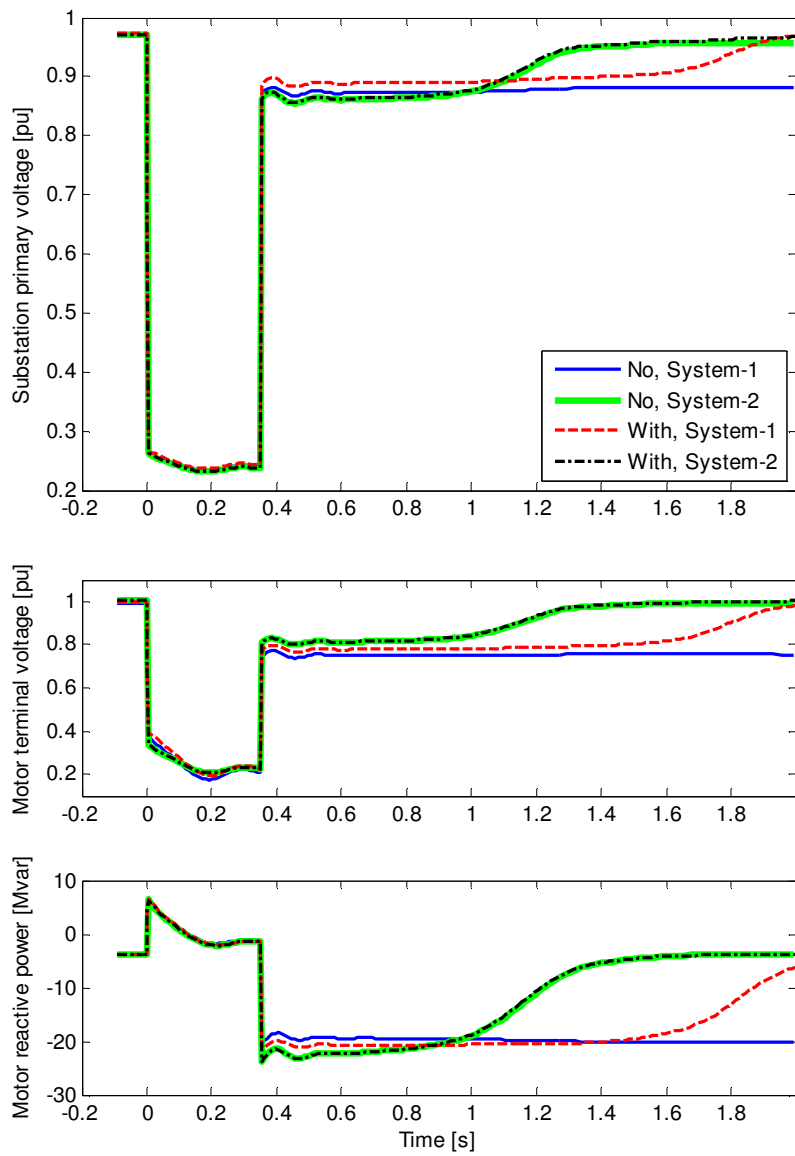

Figure 6.17. Transient voltage stability for a 0.35s fault in the middle of line 102-103. “No” and “With” mean without and with STATCOM installed at bus-1, respectively.

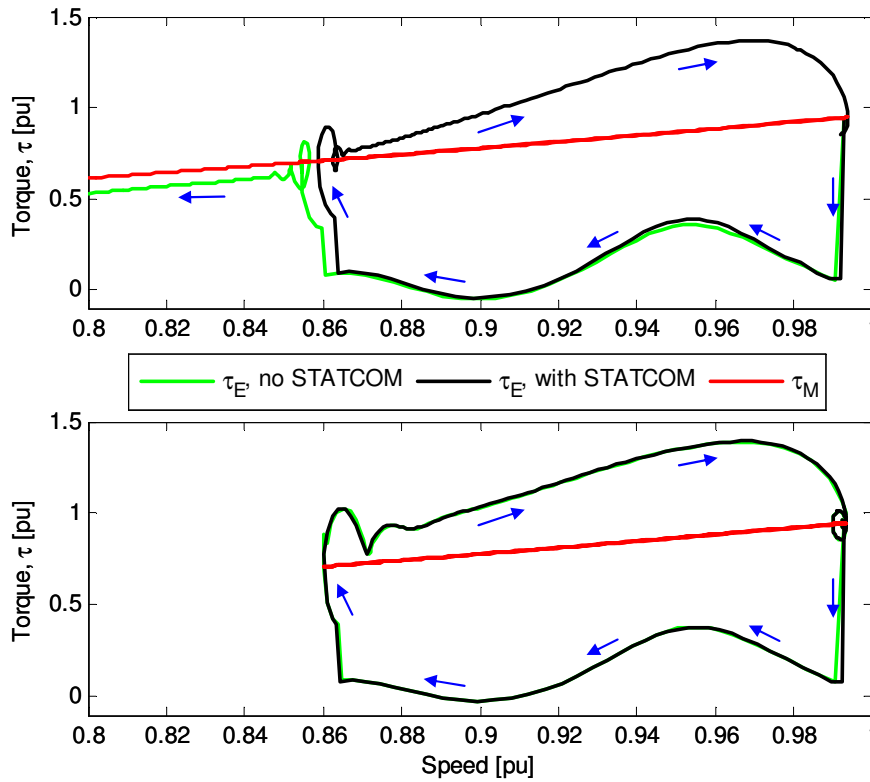

Figure 6.18. Torque speed curves of Motor-1 (upper plot) and Motor-2 (lower plot) for a 0.35s fault in the middle of line 102-103.

TABLE 6.2
SPECIFICATIONS OF THE STATCOM

Transformer	11/0.4 kV, 6 MVA, $x = 10\%$, $x/r = 25$.
Converter	0.4 kV AC / 0.6 kV DC, 5 MVA, with maximum current 1.1 pu. Voltage control mode with set point voltage 1.01 pu and bus-1 as the controlled bus.
Capacitor	0.6 kV DC, 5 Mvar.

The installation of STATCOM is shown in the upper and middle plot of Figure 6.17 to slightly decrease the voltage drop at System-1 after the fault clearing. This is because the STATCOM will try to keep the controlled bus voltage constant by injecting reactive power to the grid, while keeping the

current within the limits and keeping the DC bus voltage constant, as shown by the converter reactive power output, converter current, voltage at controlled bus and STATCOM DC bus voltage in Figure 6.19.

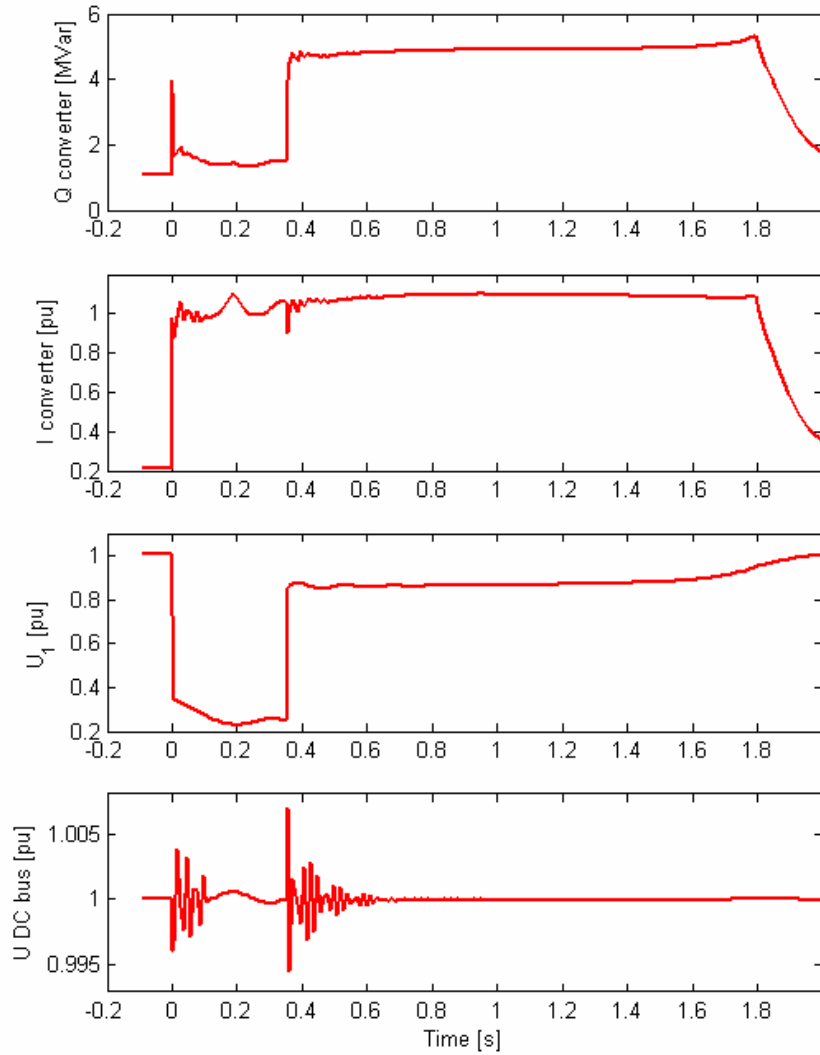

Figure 6.19. STATCOM outputs for a 0.35s fault in the middle of line 102-103.

As has been explained in Section 6.3.2, the decrease of the voltage after the fault clearing is due to the motor increased reactive power consumption. This is shown in the lower plot of Figure 6.17. With the motor terminal

voltage slightly increasing with the STATCOM installation, the motor electrical torque increases (see Equation (6-15)) and the electrical torque becomes sufficiently higher than the mechanical torque after the fault clearing. Therefore, the motor will reaccelerate to its equilibrium operation point, as shown by the motor torque-speed curve in the upper plot of Figure 6.18.

Without STATCOM, Motor-2 is more stable than Motor-1 (see Figure 6.17 - Figure 6.18), which can be explained from the impedance between the motors and the substation secondary bus. All other parameters of these two systems (the motor specifications, the substation transformers, the impedance between the substations and the grid and the impedance between the substation and the faulted point) are equal. The impedance between the motors and the substation secondary bus in System-1 is larger due to the presence of 1 km distribution line. This causes the terminal voltage of Motor-1 to decrease more than the terminal voltage of Motor-2 immediately after the fault clearing, i.e., in the time interval when the motor absorbs a large amount of reactive power (see the middle and lower plots in Figure 6.17).

6.5.2 Long-Term Large-Disturbance Voltage Stability

The long-term large-disturbance voltage stability is investigated by applying a single-phase to ground fault at both lines between bus-100 and bus-101 (will be simply called *lines 100-101*) simultaneously followed by the disconnection of the lines within 0.1s. The system is transiently stable for this fault. Assuming that the fault is permanent, the lines are then kept open and the simulation is continued until the steady state condition is reached. The stability margin is analyzed with respect to the voltage decay at transmission level.

Following the line disconnections, the voltages decay to lower levels than the minimum allowed voltages at steady state, 0.94 pu (see Section 3.5). The OLTC operations cause the transmission voltages to decrease further. Meanwhile, the substation secondary bus voltage will not come back to the OLTC regulated voltage range. In order to mitigate the problem, 8 Mvar shunt capacitors are then installed at each substation secondary bus. The simulation is then repeated with the additional shunt capacitors switched in 2s after the fault. The substation voltages and the OLTC position following the disconnection of the lines are presented in Figure 6.20 and Figure 6.21, respectively.

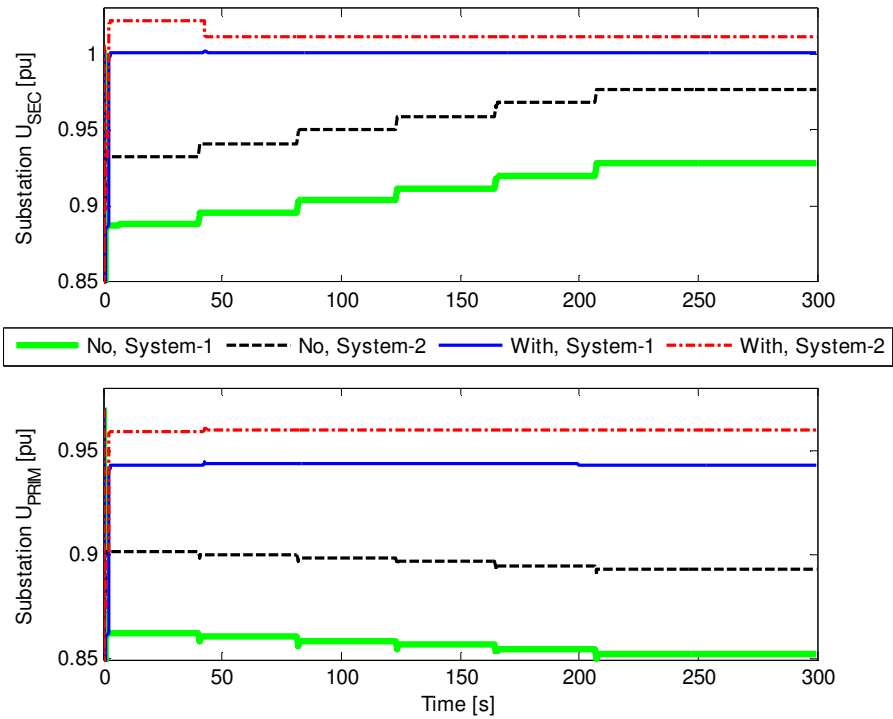

Figure 6.20. Voltage at secondary (upper plot) and primary sides of the substation following a fault and permanent tripping of two lines between bus-100 and bus-101. “No” and “With” mean without and with shunt capacitors installed at the substation secondary buses, respectively.

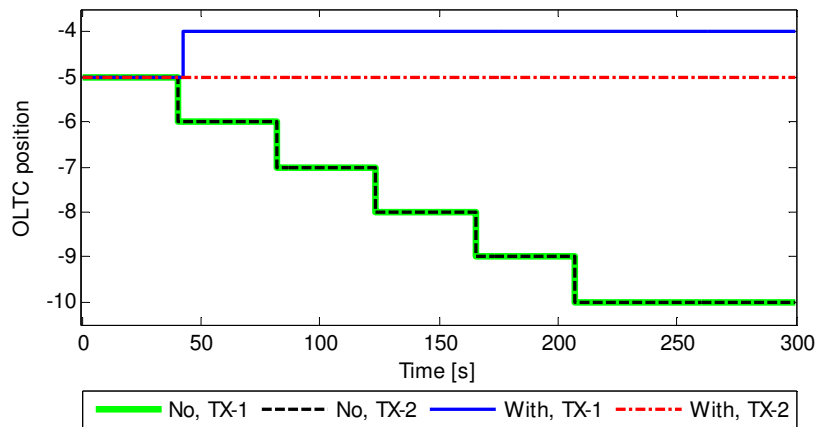

Figure 6.21. OLTC operation following a fault and permanent tripping of two lines between bus-100 and bus-101.

The decrease of the voltage at bus-101 following the disconnection of the lines can simply be understood from the increase of the electrical distance between the grid and bus-101. Meanwhile the decrease of the voltage at bus-102 is due to the increase of power flows on lines 100-102. This increase will not only cause higher losses, but will also increase the reactive power delivered from the grid (see the power circles in Figure 6.2 and Figure 6.3). The increase of the losses and the reactive power transfer will then significantly drop the voltage at bus-102.

As loads and capacitors are voltage dependent, the loads and the capacitor reactive power output increase with the increase of the voltage. However, as the total apparent load demand is significantly higher than the total capacitor reactive power, the total load increase due to the voltage increase is higher than the total capacitor reactive power increase. Therefore, the voltage increase in the distribution systems due to the OLTC operations is followed by a decrease of the voltage in the transmission system, as has been shown in Figure 6.20. For example, the recovery of the load and capacitor power at bus-21 and the decay of the voltage at bus-102 following the recovery of the voltage at bus-21 are shown in Figure 6.22.

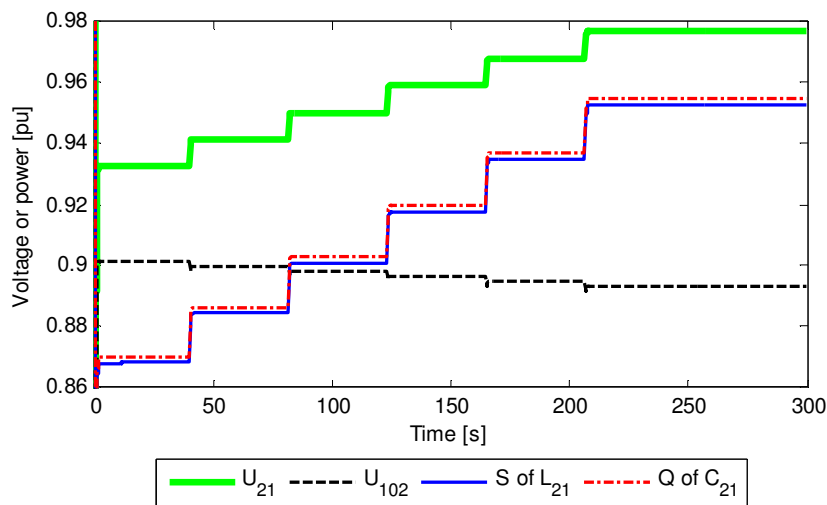

Figure 6.22. Load and capacitor power recovery, and substation primary voltage decay following substation secondary voltage recovery. “S”, “Q”, “L” and “C” mean apparent power, reactive power, load and capacitor, respectively.

6.5.3 Long-Term Small-Disturbance Voltage Stability

As has been explained in Section 6.3.2, the small disturbance voltage stability can be investigated by producing PV curves. The PV curve is obtained from a series of load flow solutions, where the load level is continuously increased, by keeping the load pf constant, until the critical load is reached. Beyond this point, the power flow solution fails to converge, which is an indication of instability. Most power system simulation software, including DIGSILENT, will only give the upper side of the PV curve.

For this particular voltage instability phenomenon, the loads are modeled as constant power loads. The reason is that many loads, such as space heating, water heating, industrial process heating and air conditioning, are controlled by thermostats, causing the loads to be constant energy. Over time, the aggregated load changes from resistive (constant impedance) to constant power [29]. Field measurements at two substations in Sweden also showed that, though the active power of the substation composite load will firstly react to the voltage reduction according to a constant impedance load, it will change close to the constant power characteristic after a few minutes [67]. Further, by modeling the loads as constant power, the system becomes unstable through the collapse of the load bus voltage, which is described in detail in [57].

The PV curves obtained by increasing the load at bus-21 are shown in Figure 6.23. Similarly as in Section 6.5.2, two conditions are presented, the first one is the original system shown in Figure 6.16 and the second one is after the installation of 8 Mvar shunt capacitors at each substation secondary bus. Obviously, the installation of the shunt capacitors will increase the stability margin, as shown in Figure 6.23.

Figure 6.23 also shows the behavior of the OLTC during the load buildup. Firstly, the OLTC operates to keep the voltage within the regulated voltage range. After the minimum position is reached, the voltage then continuously decays until the critical load is reached. Note that the critical load (the maximum load point at the PV curve) point does not necessarily mean the voltage instability limit. The voltage stability limit can appear at a lower active power transfer, when the generator current limiter, which is not considered here, is taken into account. Nevertheless, the PV curves presented in Figure 6.23 have shown the voltage instability phenomenon due to the load buildup, how the OLTC reacts to the load buildup and the role of reactive power compensation in increasing the voltage stability margin.

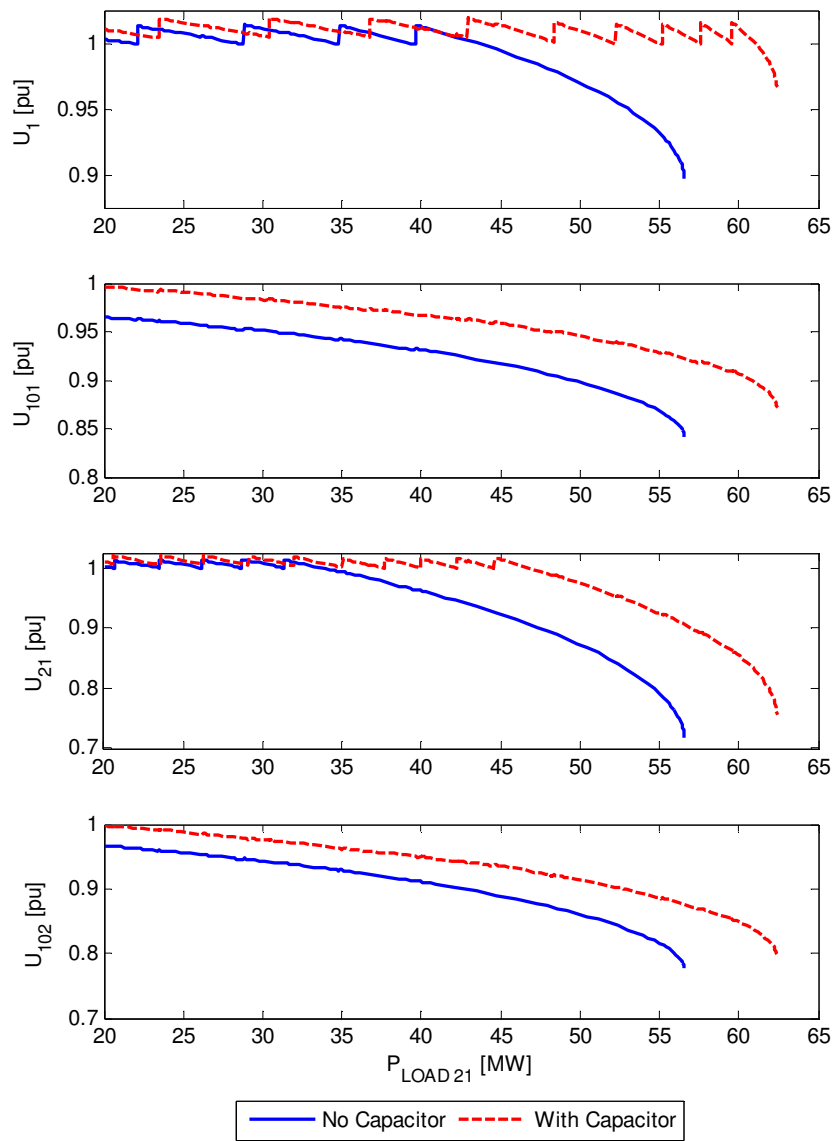

Figure 6.23. PV curves for load increase at bus-21.

6.6 Conclusions

In this chapter, voltage stability in conventional distribution systems (distribution systems without DG) has been presented. Three voltage instability mechanisms, transient voltage stability, long-term large-disturbance voltage stability and long-term small-disturbance voltage stability, have been evaluated.

The transient large-disturbance voltage stability is investigated from induction motor stalling. The long-term large-disturbance voltage stability is investigated based on the voltage decay following a transmission line outage. The small-disturbance voltage stability is investigated from the critical load in the PV curve. The importance of providing reactive power locally in distribution systems to improve voltage stability has been shown. Further, it has also been indicated that the improvement can be obtained when the distribution systems have enough reactive power reserves, in addition to the available reactive power for loss minimization, which has been explained in previous chapters.

The type of reactive power compensation needed to mitigate voltage instability or to increase the voltage stability margin is shown to depend on the type of voltage stability. Mechanically switched shunt capacitors will be able to mitigate long-term voltage instability with a time frame longer than a minute. However, the mechanically switched shunt capacitors are too slow to mitigate transient voltage instability with a time frame from a few hundreds of milliseconds. In this case, a voltage and reactive power device with dynamic response is needed.

Chapter 7

Voltage Stability in the Presence of Distributed Generation

This chapter presents voltage stability in distribution systems in the presence of distributed generation (DG). Both synchronous machine and induction machine DG are investigated. The impact of these DGs and their possible operation modes on different voltage instability mechanisms; transient voltage instability, long-term large-disturbance voltage instability and long-term small-disturbance voltage instability; are evaluated further detailed in a case study.

Results related to this chapter are published in Paper XI.

7.1 Introduction

It has been shown in Chapter 6 that the increase of transmission loading or the increase of power transmitted from a remote generator to a load center will bring the power system closer to voltage instability. Generating power locally from DG will obviously increase the maximum loadability of the distribution system. Further, as has been indicated by the PV curves in Chapter 6, reactive power support in the distribution system will increase the maximum power transfer capability from a transmission to a distribution system. Reactive power cannot be transmitted over long distances, but has to be provided locally.

Hence, it is expected that the presence of DG generating reactive power will increase the maximum power transfer capability from a transmission to a distribution system. Meanwhile, the presence of DG absorbing reactive power, induction machine DG for instance, has the potential to decrease this maximum power transfer capability. This expectation has been shown true in [47] and [68], where the maximum power transfer capability from the grid to

the load increases with the presence of synchronous machine DG and decreases with the presence of induction machine DG.

Further, it has also been analyzed in Chapter 6 that transient voltage instability can appear in different forms caused by different mechanisms. Hence, in order to obtain a comprehensive understanding of the impact of synchronous and induction machine DG on voltage instability, in addition to the impact on the long-term small-disturbance voltage stability (as shown in [47] and [68]), the impact on transient and long-term large-disturbance voltage stability needs to be investigated. The impact of different possible operations of synchronous machine DG and induction machine DG on various voltage instability mechanisms also needs to be evaluated.

This chapter will investigate voltage stability in the presence of synchronous machine DG and induction machine DG, which will be simply called *synchronous DG* and *induction DG*, respectively. Different possible synchronous DG and induction DG operations and their impact on different voltage instability mechanisms are evaluated. The synchronous DG considered here is a salient pole synchronous generator for combined heat and power (CHP) application, with dispatchable power output. The induction DG considered is a squirrel cage induction generator for wind power application. DG applications for both CHP and wind power have been widely available in Sweden.

The chapter starts with a brief overview of modelling and dynamic characteristics of synchronous and induction DG. An example of a single DG system supplying a local load connected to a remote grid is presented. The chapter is ended with a case study, which is based on the system presented in Chapter 6.

7.2 Dynamic Characteristics of DG

The dynamic characteristics of synchronous and induction DG in this section will be analyzed theoretically from a literature review and analytically based on the simple system in Figure 7.1, where a 4 MW DG locally supplies a 4 MW load. The analysis will focus on the dynamic performance of the DG during a grid fault.

DG is either synchronous DG or induction DG with its transformer and shunt capacitor compensation, which is shown in Figure 7.2. The impedance of the line in *ohm per km* is the same as the impedance of the transmission line in Table 6.1. The OLTC transformer keeps the substation secondary

voltage within the range 0.99 to 1.01 pu. The grid voltage is kept at 1.00 pu. The specifications of the DG system are presented in Table 7.1.

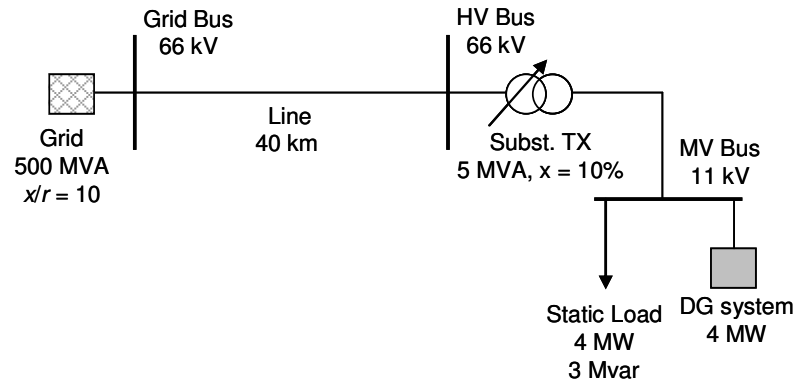

Figure 7.1. One line diagram to analyze dynamic performance of a DG system.

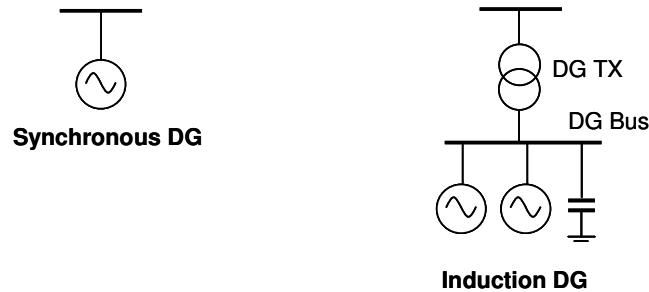

Figure 7.2. One line diagram of the “DG system” in Figure 7.1.

The composite model for the synchronous DG is shown in Figure 7.3, where notations U and P in the figure represent voltage and active power, respectively. The voltage controller represents an excitation system, where IEEE Modified Type AC1 Excitation System [69] that is available in DIgSILENT library is used. The primary controller represents a speed-governing system, where IEEE Type 1 Speed Governing Model that is available in DIgSILENT library is used. The parameters for the voltage controller mostly follow the parameters given in [57] for the IEEE Modified Type AC1 Excitation System. The parameters for the primary controller follow the ones available in DIgSILENT library.

A composite model for the induction DG is shown in Figure 7.4, where notation P indicates active power. Further explanation about modelling induction generator wind turbine using DIgSILENT can be found in [70]. The

models for the Turbine and Shaft follow the ones available in DIgSILENT library.

TABLE 7.1
SPECIFICATIONS OF THE DG SYSTEM

Synchronous Generator	$S = 5 \text{ MVA}$, $U = 11 \text{ kV}$, $\text{pf} = 0.84$, $x_d = 1.5 \text{ pu}$, $x_q = 0.75 \text{ pu}$, $x_d' = 0.256 \text{ pu}$, $T_d' = 0.53\text{s}$, $x_d'' = 0.168 \text{ pu}$, $x_q'' = 0.184 \text{ pu}$, $T_d'' = 0.03\text{s}$, $T_q'' = 0.03\text{s}$, $r_s = 0.0504 \text{ pu}$, $H = 2.1\text{s}$.
Induction Generator	<p><u>Transformer</u> 11/0.96 kV, 5 MVA, $x = 10\%$, $x/r = 10$</p> <p><u>Generator</u> $P = 2 \text{ MW}$, $S = 2.39 \text{ MVA}$, $U = 0.96 \text{ kV}$, $\text{pf} = 0.855$, $r_s = 0.01 \text{ pu}$, $x_M = 3 \text{ pu}$, $x_S = 0.15 \text{ pu}$, $r_R = 0.01 \text{ pu}$, $x_R = 0.1 \text{ pu}$, 1485 rpm.</p> <p><u>Shunt capacitor</u> $U = 0.96 \text{ kV}$, $Q = 1.2 \text{ Mvar}$.</p>

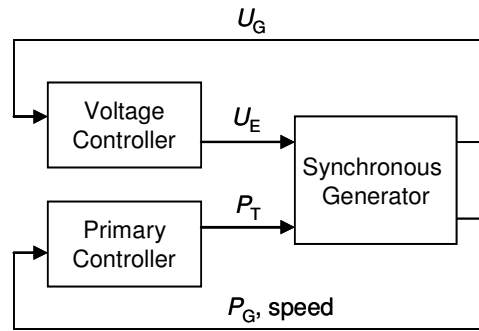

Figure 7.3. Composite model of the synchronous DG.

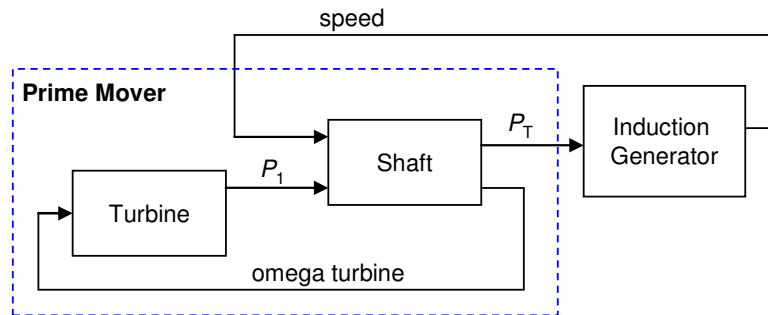

Figure 7.4. Composite model of the induction DG.

7.2.1 Synchronous Machine DG

The ability of a synchronous DG to remain stable during a grid fault is related to rotor angle stability, which can be determined by using *the equal area criterion* [57] (also called *the critical area method* [71]). The determination of rotor angle stability is beyond the scope of this thesis, and, thereby, will not be discussed here. However, a synchronous DG affects voltage stability, which is of interest for this chapter.

To get an overview of the dynamic performance of a synchronous DG, consider that a three-phase fault occurs at the HV bus in the system in Figure 7.1. The rotor angle of the DG for 0.4s and 0.7s fault durations is shown in Figure 7.5. The voltage, active power and reactive power of the synchronous DG for the 0.4s fault duration are shown in Figure 7.6. The phenomena can be explained as follows:

1. The voltage dip due to the grid fault will significantly reduce the generator terminal voltage.
2. The generator keeps supplying reactive power during the fault, which keeps the DG terminal voltage higher than the voltage at the faulted point during the fault.
3. Immediately at the time of the fault clearing, the voltages both at the fault point and at the DG terminal increase. The DG decreases the reactive power output significantly (in this particular case, the DG even absorbs a large amount of reactive power). The reduction of the reactive power output causes the DG terminal voltage after the fault to be lower than the pre-fault voltage. The exciter responds by bringing the DG voltage back to the set point voltage (when the DG is operated at a constant voltage) or back to the set point reactive power (when the DG is operated at a constant pf).
4. The reduction of the DG terminal voltage decreases the capability of the DG to deliver power.
5. If the rotor angle increases too much, passing the critical angle, the generator will not return to the pre-fault state.

It is indicated in point 2 above that, a synchronous DG gives voltage support to the distribution system during a fault by continuously supplying reactive power during the fault. In this sense, a synchronous DG (a synchronous generator close to the loads [74]) can be expected to reduce the transient voltage stability problem.

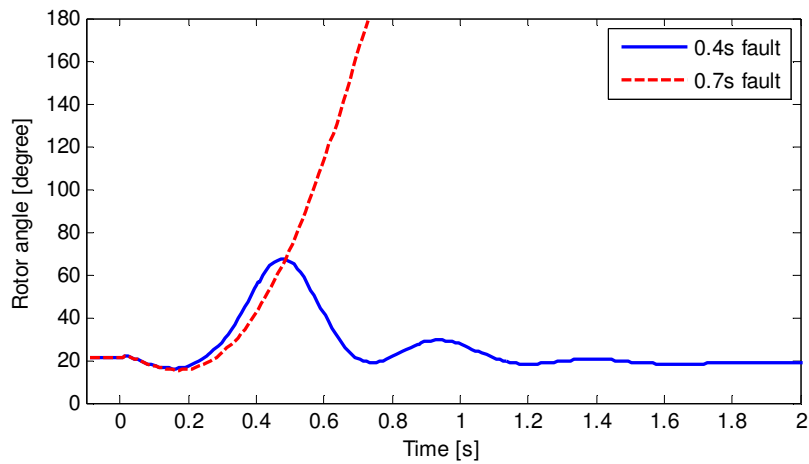

Figure 7.5. Rotor angle of the synchronous machine DG in Figure 7.1 on a 0.4s and 0.7s three-phase faults at the HV bus.

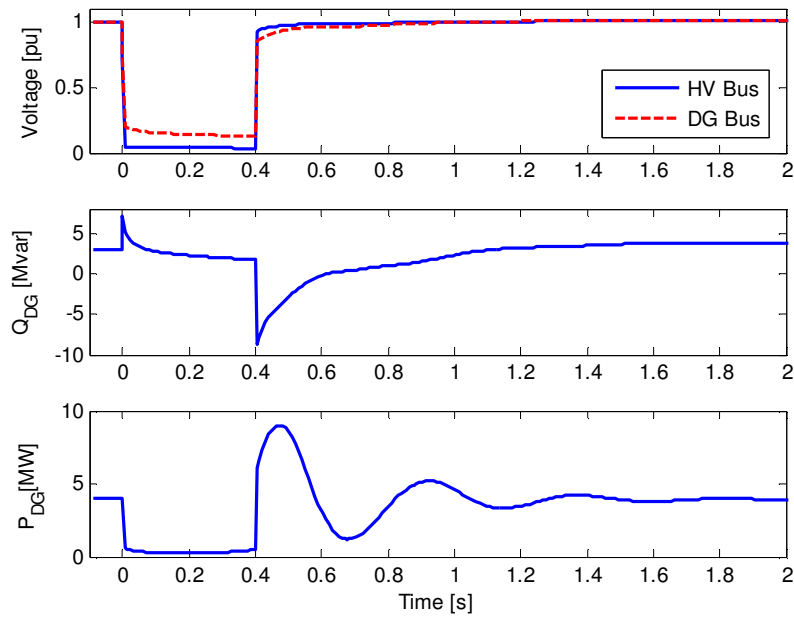

Figure 7.6. Dynamic performance of the synchronous machine DG on a 0.4s three-phase fault at the HV bus.

The response of the DG excitation, will also define how much the synchronous DG supports the voltage stability, as it affects the reactive power

reduction and the time needed to recover the voltage or reactive power supply. This is shown in Figure 7.7. The parameters for the exciter follow the ones in [57] for the result marked as *Normal Exciter*. *Faster Exciter* and *Slower Exciter* are obtained by modifying the time constants.

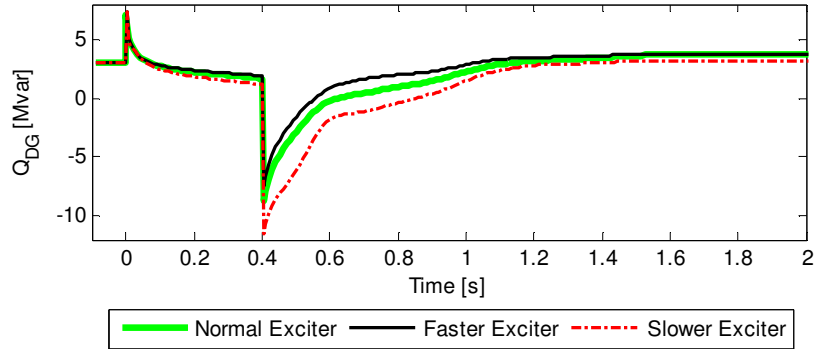

Figure 7.7. DG reactive power output for different exciter parameters.

7.2.2 Induction Machine DG

As has been explained in Chapter 6, the ability of an induction machine to remain stable during a grid fault is related to voltage stability. Obviously, the dynamic performance of an induction machine DG is analogue to the dynamic performance of the induction motor that has been explained in Section 6.3.2, by reversing the equation of motion in Equation (6-14) as

$$2H \frac{d\omega}{dt} = \tau_M - \tau_E \quad (7-1)$$

which indicates that the induction generator will accelerate during a fault. Analogue to the torque speed analysis for an induction motor, the generator will be able to decelerate back to its equilibrium operating speed as long as τ_E is higher than τ_M or when ω is lower than the critical speed ω_{CR} when the fault is cleared.

For example, consider that two independent three-phase faults occur at the HV Bus in the system in Figure 7.1. The first fault is lasting for 0.4s where the induction generator remains stable, and another fault is lasting for 0.65s where the induction generator becomes unstable. The dynamic performance of an induction generator during the grid fault is shown in Figure 7.8, which can be explained as follows:

1. The voltage dip due to the grid fault will significantly reduce the generator terminal voltage. The reduction of the generator terminal voltage decreases the capability of the generator to deliver power.
2. The reduction in active power delivered during the fault causes the generating unit to accelerate.
3. After the fault is cleared, the speed is still significantly higher than the pre-fault speed. This causes increased reactive power consumption of the induction generator.
4. This increased reactive power consumption decreases the generator terminal voltage.
5. If the speed increases too much, passing the critical speed, the generator may not return to the pre-fault state (hence the induction generator stability may be considered as speed instability [72]). This will be accompanied with the increased reactive power consumption and depressed voltages nearby the generator, which leads to a voltage collapse in the power system.

Further, analogue to the induction motor, the electrical torque of the induction generator can be increased by increasing the generator terminal voltage. The generator terminal voltage can be increased by increasing the distribution system operating voltage or by increasing the reactive power compensation. Increasing of the distribution system operating voltage has been investigated in Chapter 3 - Chapter 5, and hence, will not be discussed in this chapter.

An induction generator is normally compensated with mechanically switched shunt capacitors. The size of the shunt capacitors can be increased in order to improve the dynamic performance of the induction generator. However, DG has the potential to cause overvoltage on low load and the induction machine DG with shunt capacitors is not able to perform voltage control. Hence, the risk of overvoltage increases with the increase of the shunt capacitor compensation. Further, as has been explained in the previous chapters, reactive power output of a shunt capacitor is proportional to the square of the voltage, which means that the reactive power compensation by the capacitor is not effective when the fault causes a severe voltage dip.

As an alternative, a STATCOM that has reactive power output linearly proportional to the voltage can be used to increase the effectiveness of the compensation. Further, the STATCOM can be operated to keep the voltage constant. Hence, the STATCOM can be expected to mitigate the risk of overvoltage.

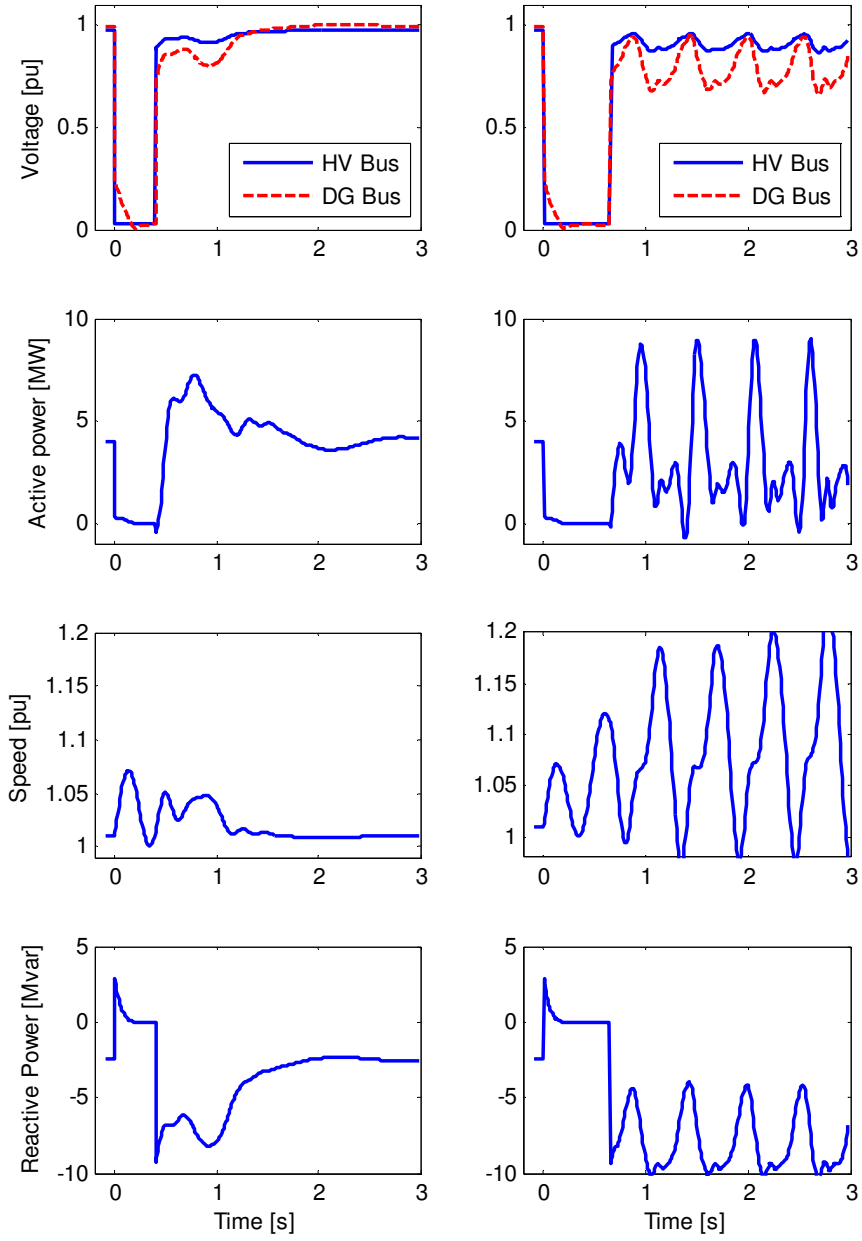

Figure 7.8. Dynamic performance of the induction generator for three-phase faults at the HV bus. The fault duration is 0.4s for the left plots and 0.65s for the right plots.

To give an overview of the impact of the reactive power compensation to the stability of the induction machine, the simulation for a 0.65s fault at the HV bus is repeated by connecting an additional 1.2 Mvar shunt capacitor and a 1.2 MVA STATCOM. The result is shown in Figure 7.9, where *Normal Cap* is with the original 1.2 Mvar capacitor, *Larger Cap* is 1.2 Mvar original capacitor plus 1.2 Mvar additional capacitor, and *Cap + STATCOM* is 1.2 Mvar original capacitor plus 1.2 MVA STATCOM. Figure 7.9 shows that increasing the capacitor compensation will improve the dynamic performance of the generator, but in this particular case, doubling the capacitor size is not enough to keep the generator stable. On the other hand, installing a STATCOM of the same size is enough to keep the generator stable.

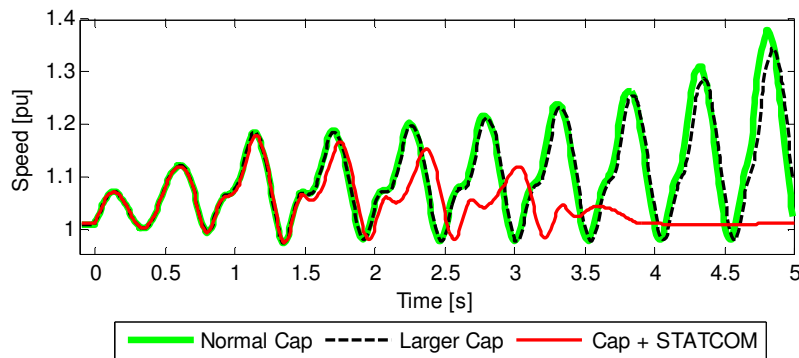

Figure 7.9. Stability of the induction generator with different reactive power compensation.

As has been explained in Chapter 6, the installation of a STATCOM has to be coordinated with the OLTC in the substation in order to enable the STATCOM to effectively respond to an emergency. Keeping the generator stable with a STATCOM installation that has been shown in Figure 7.9 is only possible when the STATCOM is properly coordinated with the OLTC.

As previously described, the OLTC transformer keeps the substation secondary voltage within the range 0.99 to 1.01 pu, which can be achieved by various combinations of STATCOM output and OLTC position. With the objective to improve the stability of the induction generator, the OLTC has to keep the transformer primary to secondary winding ratio (N_p / N_s) low (in order to keep the substation secondary bus voltage high) and the STATCOM can be set to absorb reactive power to bring the voltage back within the OLTC operating range. Two examples of steady state operating conditions are presented in Table 7.2. Case-1 is the case where the substation secondary bus voltage is boosted by the OLTC and the STATCOM absorbs reactive power.

Case-2 is the case where the STATCOM generates reactive power and thereby the OLTC does not need to boost the substation secondary voltage. The stability of the generator on these two operating conditions is shown in Figure 7.10. The induction DG is stable for Case-1, but not stable for Case-2.

The drawback of the STATCOM – OLTC coordination shown by Case-1 is the increase of losses. In practise, the steady state objective in minimizing losses, which has been explained in Chapter 3 to Chapter 5, and the dynamic objectives in increasing stability margins have to be compromised, which is not discussed here.

TABLE 7.2
STEADY STATE OPERATING CONDITIONS FOR DIFFERENT
STATCOM AND OLTC COORDINATION

	Case-1	Case-2
OLTC position	-7	-5
DG TX reactive power flow [Mvar]	2.2	0.5
STATCOM Output [Mvar]	-0.68	0.94
MV Bus voltage [pu]	1.009	1.009
Losses* [MW]	0.1	0.05

* Including the STATCOM losses.

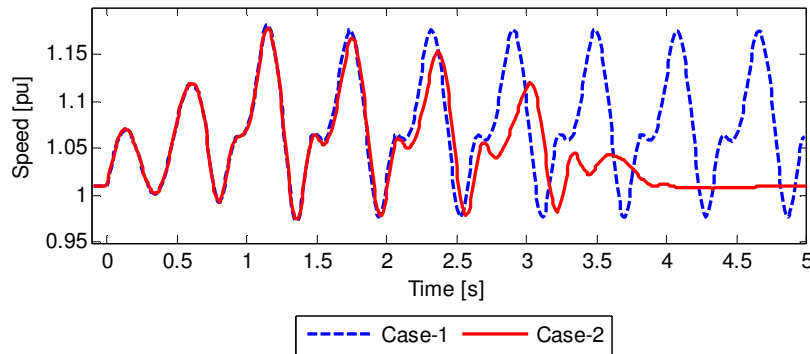

Figure 7.10. Stability of the induction generator with different coordination between the OLTC and the STATCOM.

7.3 Case Study

The voltage stability in the presence of DG is tested on the system shown in Figure 7.11. This system is the same as the test system for the case study in Section 3.6, except for DG-1 and DG-2 that are connected to bus-3 and bus-9, respectively. In this case, DG-1 and DG-2 consist of two DG systems each. A DG system means a synchronous generator; or two induction generators with a shunt capacitor and a transformer; which is shown in Figure 7.2. The specifications of the DG systems have been presented in Table 7.1.

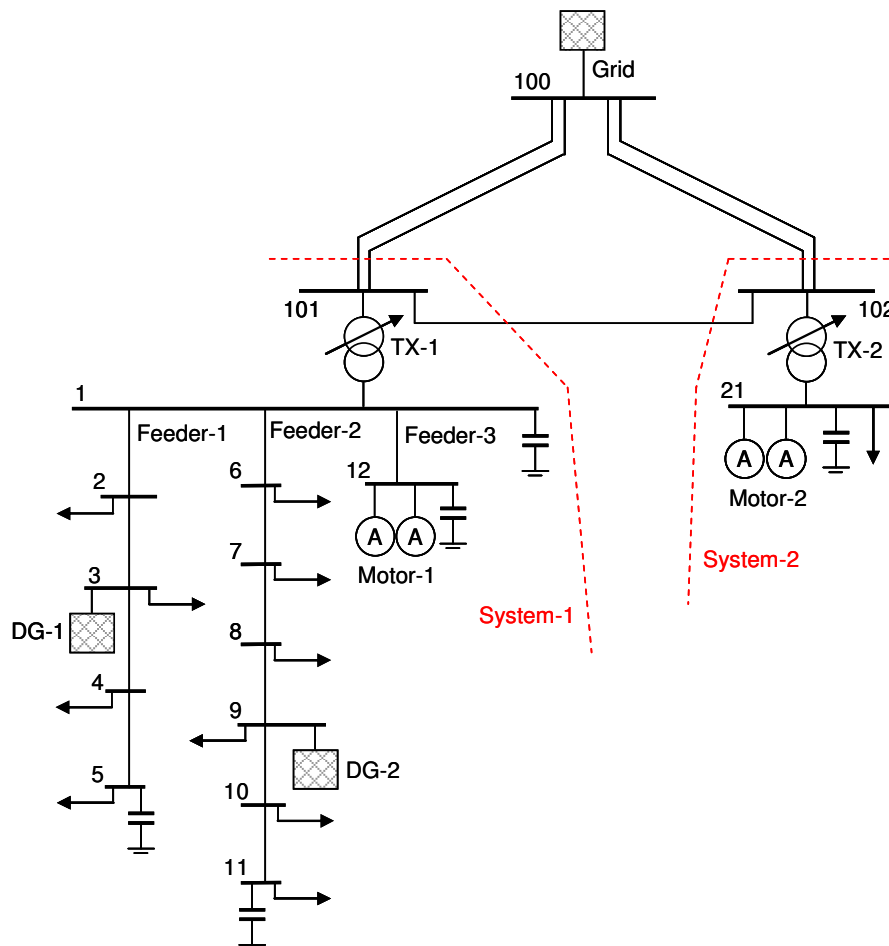

Figure 7.11. One line diagram of the system under study.

7.3.1 Cases with Synchronous Machine DG

A synchronous machine DG can operate at a constant pf or a constant voltage. The reactive power output of the synchronous DG operating at a constant pf will not be changed according to the change of the load demand in the distribution system or following the change of the generator terminal voltage. Overvoltage on minimum load will, therefore, limit the minimum lagging pf operation.

Reactive power should be supplied locally. Therefore, except when the distribution system has excessive reactive power from shunt capacitors, which is not the case here, it is not realistic to operate synchronous DG at a leading pf.

Based on the conditions above, three different synchronous machine DG operations are investigated; synchronous machine DG operated at a unity pf (*Unity pf case*), synchronous machine DG operated at a constant 0.95 lagging pf (*Lagging pf case*) and synchronous machine DG operated at a constant 1.02 pu voltage (*Constant Voltage case*). 0.95 lagging pf operation is the minimum DG lagging pf operation that will not cause overvoltage on minimum load maximum DG. The minimum load considered in the case study in this chapter is 30% of the nominal load.

In all cases, the synchronous DG is assumed to continuously operate at 4 MW power output.

7.3.2 Cases with Induction Machine DG

An induction machine DG is normally compensated with shunt capacitors. Shunt capacitors with a total size corresponding to 30% of the DG nominal power output is common [47]. The capacitors are usually switched on or off in several steps. Similarly as for a constant pf operation of the synchronous machine DG, switching on or off of the induction machine DG shunt capacitors will not be based on the distribution system loading. Overvoltage on minimum load will, therefore, limit the maximum size of the shunt capacitor compensation.

As has been explained in Chapter 5 an induction machine DG can cause both undervoltage and overvoltage. The undervoltage may occur on maximum load and maximum DG. In this case, with a DG capacitor compensation of 30% of the DG power, the voltages at feeder-ends may suffer undervoltage on maximum load and maximum DG, when the OLTC of TX-1 (OLTC-1) is set to keep bus-1 within 1.01 ± 0.01 pu, as in the case without DG or in the case with synchronous DG. The set point of the OLTC is therefore increased to be

1.02 pu in this case with induction DG, with the deadband remaining unchanged.

Based on the conditions above, three different DG operations are investigated; induction DG with normal capacitor compensation, which is 30% of the generator rated power (*Normal C* case), induction DG with larger capacitor, which is 60% of the generator rated power (*Larger C* case); and induction DG with larger capacitor and STATCOM, where the size of the STATCOM is 30% of the generator rated power (*Larger C + STATCOM* case). The STATCOM is connected to the DG Bus (see Figure 7.2).

The capacitor compensation of 60% of the induction DG rated power is the maximum capacitor size that will not cause overvoltage on minimum load. The STATCOM size of 30% of the induction DG rated power refers to a case in Rejsby Hede, Denmark, where an 8 MVA STATCOM is installed for a 24 MVA squirrel cage induction generator wind farm [73].

As has been explained in Chapter 6, a STATCOM can be operated at a constant reactive power or at a constant voltage. However, in this particular case, as the capacitor (with a size of 60% of the induction DG rated power) already almost causes overvoltage on minimum load, the STATCOM has to be operated at a constant voltage. Here, the STATCOM is operated to keep the voltage at the DG system connection point (bus-3 and bus-9) constant at 0.985 pu. With this voltage, the reactive power flow on the secondary side of the DG TX (see Figure 7.2) is almost zero on maximum load and maximum DG output.

7.4 Simulation Results and Discussions

With the aim to observe the impact of different generator technologies for DG on voltage stability, the procedures in the case study in Chapter 6 are repeated. In order to get a clearer observation of the phenomena, some adjustments are made. For the transient voltage stability study, the duration of the fault is varied, and for the long-term large-disturbance voltage stability study, the location of the load buildup is changed.

- The transient voltage stability is investigated by applying a bolted three-phase fault in the middle of line 101-102. The fault clearing time is set differently for different DG.
- The long-term large-disturbance voltage stability is analyzed applying a single-phase to ground fault at both lines 100-101 simultaneously followed by the disconnection of the lines within 0.1s.

-
- The long-term small-disturbance voltage stability is examined by increasing the load at bus-3. The load at the DG connection point (bus-3) is selected because it will clearer show the impact of the DG.

The simulations results presented are for the maximum load demand (the nominal load specified in Table 6.1), except otherwise noted. As explained in Chapter 6, the voltage stability will be more critical when the load is higher.

7.4.1 DG Impact on Transient Voltage Stability

Synchronous machine DG

The dynamic response of the motors to a 0.4s three-phase fault in the middle of line 101-102 in the presence of synchronous DG is presented in Figure 7.12. As expected, synchronous DG will improve the transient voltage stability in the distribution system. This is because the presence of synchronous DG increases the voltages in the distribution system during the fault (compare to the case without DG) and ensures the fast voltage recovery after the fault, as shown in the upper plot of Figure 7.12. As has been explained in Section 7.2.1, the voltage increase and the voltage recovery is due to the DG reactive power support during and immediately after the fault, which is shown in Figure 7.13.

The improvement is shown not only in the distribution system where the DG is connected, but also in the nearby distribution system. A voltage collapse and a voltage recovery in one distribution system will also affect the voltage collapse and the voltage recovery in nearby distribution systems.

It is shown in Figure 7.12 that the highest voltage stability improvement is obtained for the DG operating at a constant voltage. However, in this case, whether the DG is operated at a constant voltage or at a constant pf is not important. The important thing is the DG terminal voltage (or the DG reactive power output) before the fault. The higher the steady state DG terminal voltage (or the higher the DG reactive power output) before the fault, the better the stability of Motor-1 is. This is because the voltage recovery also implies the reactive power recovery and vice versa, as can be seen from the voltage and the reactive power of DG-1 in Figure 7.13 and Figure 7.16.

The impact of the steady state DG terminal voltage (or DG reactive power output) before the fault on the stability of Motor-1 can be concluded by comparing Motor-1 and DG reactive power at both maximum load and minimum load (compare Figure 7.12 with Figure 7.13 and Figure 7.14 with Figure 7.15).

On maximum load, DG-1 initial condition is

$$Q_{\text{Constant Voltage}} > Q_{\text{lagging}} > Q_{\text{unity}}$$

Therefore, the recovery time of Motor-1 is

$$t_{\text{Constant Voltage}} < t_{\text{lagging}} < t_{\text{unity}}$$

On the other hand, on minimum load, the initial condition is

$$Q_{\text{lagging}} > Q_{\text{Constant Voltage}} > Q_{\text{unity}}$$

Therefore, the recovery time of Motor-1 is

$$t_{\text{lagging}} < t_{\text{Constant Voltage}} < t_{\text{unity}}$$

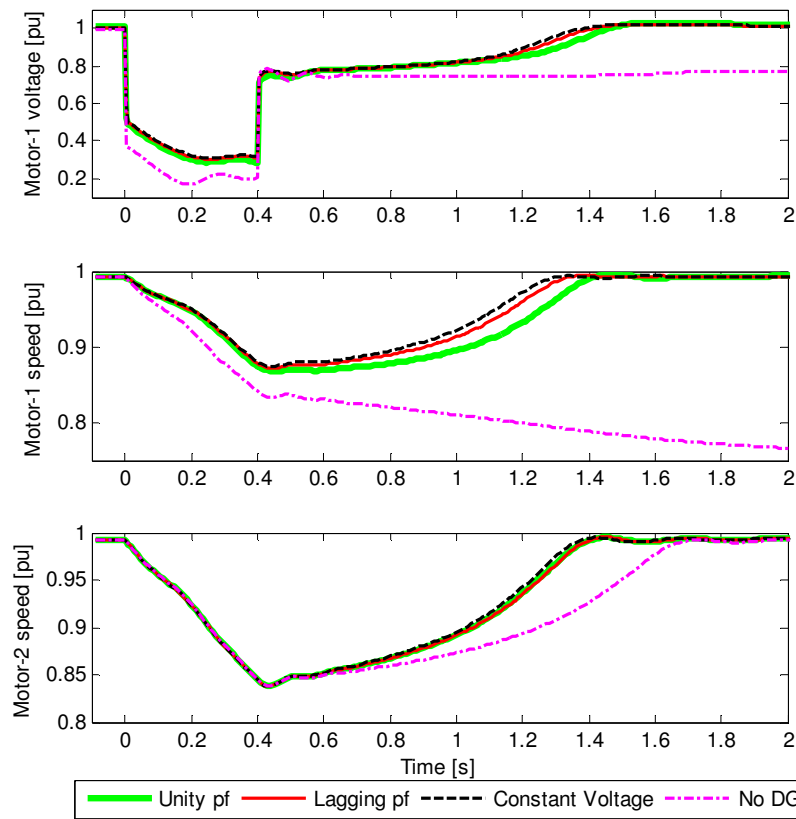

Figure 7.12. Dynamic response of the motors to the 0.4s three-phase fault in the middle of line 101-102 in Figure 7.11, for different cases with synchronous DG.

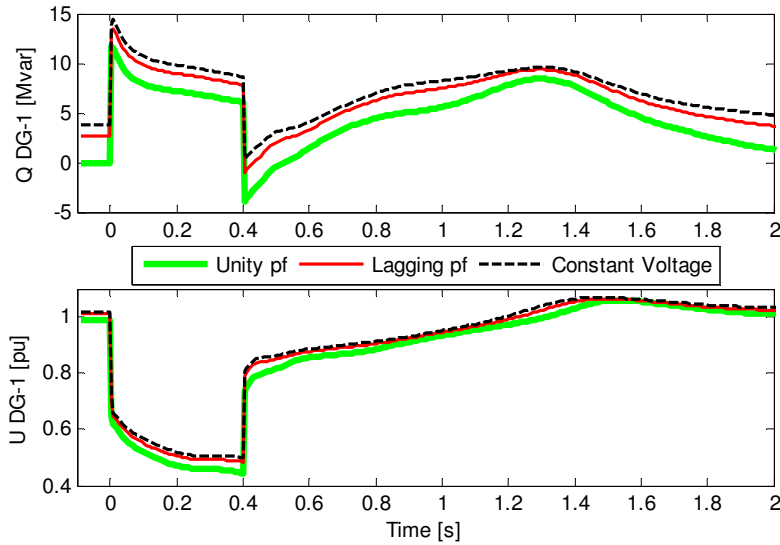

Figure 7.13. DG-1 reactive power and terminal voltage in response to the 0.4s three-phase fault in the middle of line 101-102 in Figure 7.11.

The case where the DG reactive power goes back to the pre-fault reactive power output, but the DG voltage does not, and vice versa, can be observed in the long-term large-disturbance voltage stability in the next section.

The role of the excitation response time on voltage stability improvement can be observed in Figure 7.16. The DG is operated at a unity pf for *Normal Exciter* and *Faster Exciter* (see Section 7.2.1 for the definitions of *Normal Exciter* and *Faster Exciter*). The figure indicates that, in this particular case, more immediate motor speed recovery (voltage stability improvement) can be obtained by shortening the response time of the exciter rather than by changing the DG operation mode.

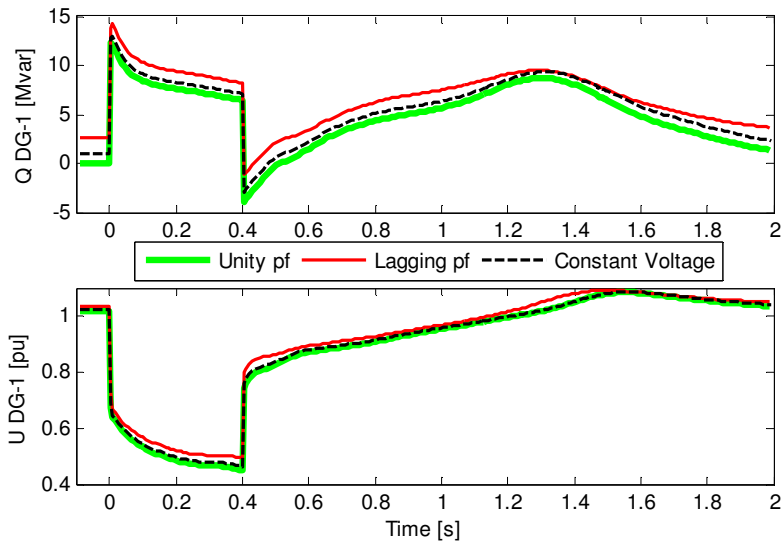

Figure 7.14. DG-1 reactive power and terminal voltage on minimum system load.

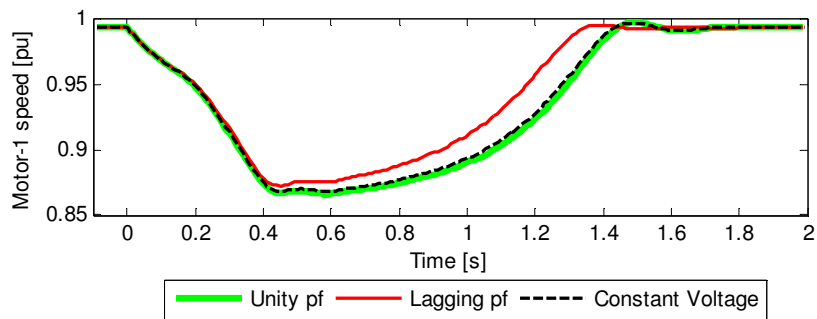

Figure 7.15. Speed of Motor-1 on minimum system load.

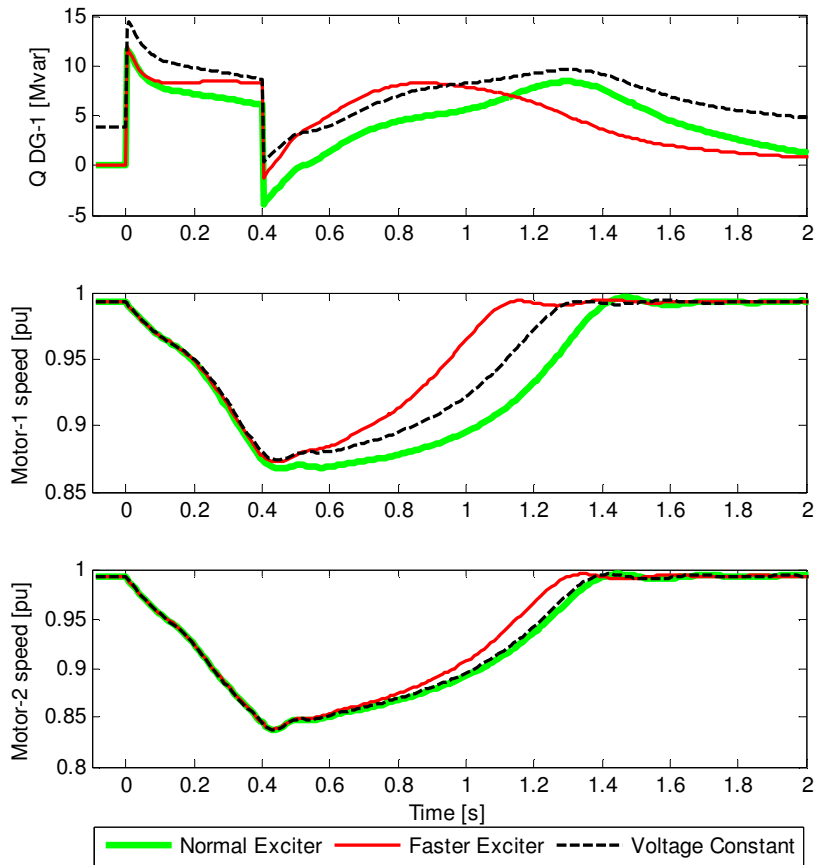

Figure 7.16. Dynamic response of the DG and the motors for different exciter excitation time constant and DG operation mode.

Induction Machine DG

As has been explained in Section 7.2.2, an induction DG will absorb a large amount of reactive power immediately after the fault is cleared. With the DG absorbing a large amount of reactive power, larger reactive power (compared to the case without DG) flows from the grid to the distribution system, which results in a larger voltage drop to the distribution system. Hence, except if there is a reactive power source in the distribution system that can meet the reactive power demand of the induction DG, the induction

DG is potential to degrade the transient voltage stability in the distribution systems.

For example, Figure 7.17 shows the dynamic response of the induction motors to a 0.18s bolted three-phase fault in the middle of line 101-102. The resulted figures are based on induction DG generating rated power. As expected, the transient voltage stability deteriorates with the presence of induction DG, except for the case *larger C + STATCOM*. The case *larger C + STATCOM* is shown to improve the voltage stability of Motor-1, but not Motor-2.

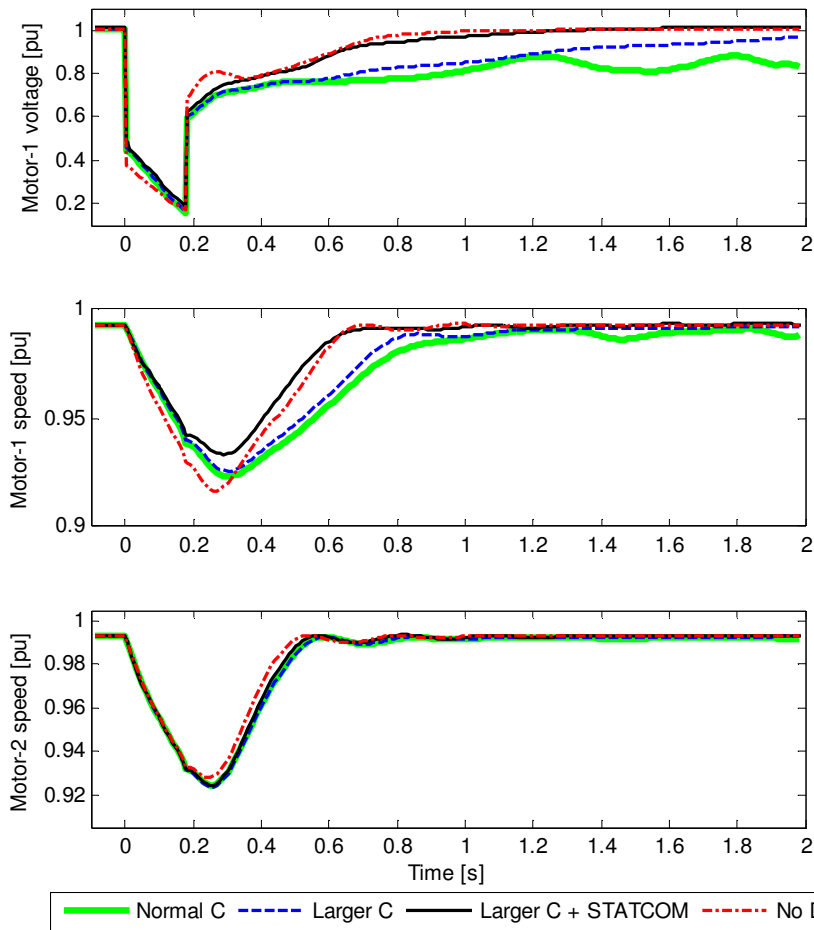

Figure 7.17. Dynamic response of the motors to the 0.18s three-phase fault in the middle of line 101-102 in Figure 7.11, for different cases with induction DG.

The dynamic performance of DG-1 due to the fault event is shown in Figure 7.18. Reactive power of DG-1 in Figure 7.18 means reactive power from the DG system (reactive power flow on the high voltage side of DG TX, see Figure 7.2). Figure 7.18 shows that DG-1 becomes unstable due to the fault, for the case *Normal C*. The instability is shown by the continuous increase of the generator speed, accompanied with the depressed generator terminal voltage and the increased reactive power consumption. In this case, the DG has to be disconnected before it causes a voltage collapse in the system.

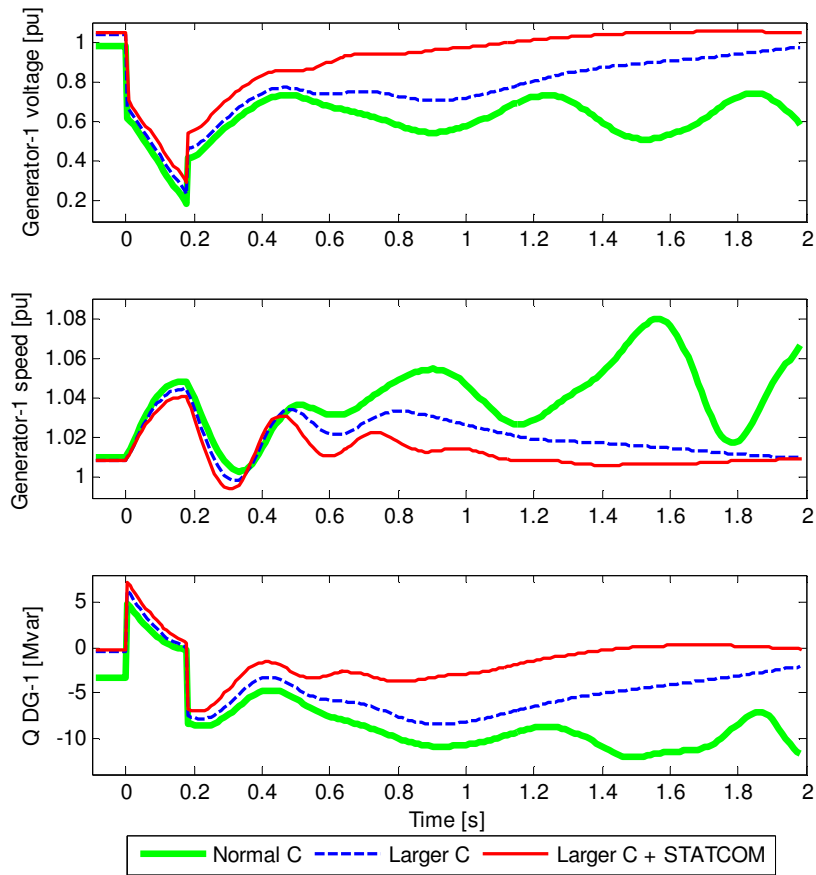

Figure 7.18. Dynamic response of DG-1 to the 0.18s three-phase fault in the middle of line 101-102 in Figure 7.11, for different reactive power compensation.

Furthermore, Figure 7.17 - Figure 7.18 indicate that the increase of the induction DG shunt capacitor compensation will improve the stability of the

induction DG. However, though the shunt compensation has been increased to the maximum size (see Section 7.3.2), the compensation is still not enough to prevent the deterioration of the transient voltage stability in the distribution system. Reactive power compensation with voltage control capability, like a STATCOM, is needed to mitigate the deterioration of the transient voltage stability in System-1 in Figure 7.11.

7.4.2 DG Impact on Long-Term Large-Disturbance Voltage Stability

Synchronous machine DG

The OLTC operations and the substation voltages following a fault and permanent trip of two lines between bus-100 and bus-101 (will be simply called *lines 100-101*), for the cases with synchronous DG, are presented in Figure 7.19 and Figure 7.20, respectively. Figure 7.19 indicates that the presence of synchronous DG decreases the number of OLTC operations due to this disturbance. Note that the number of operations of OLTC-1 for the case without DG is shown to be lower than for the unity pf case. However, this is just because the minimum OLTC position, in the case without DG, is reached.

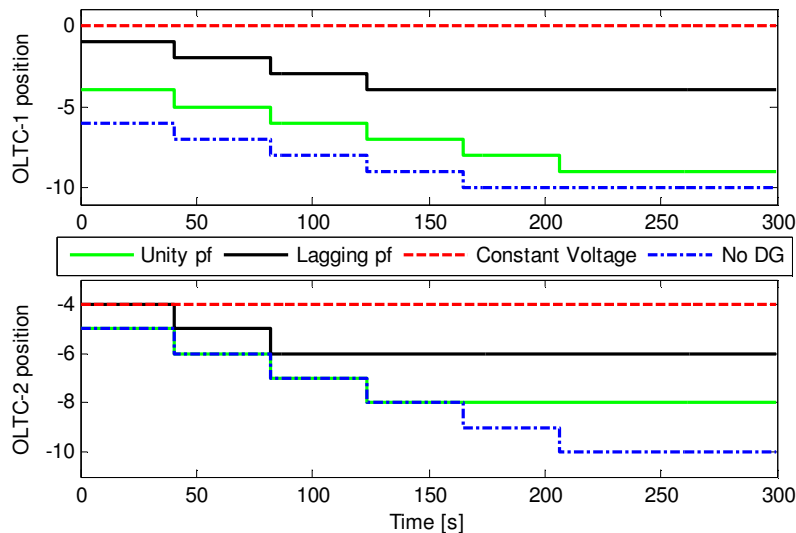

Figure 7.19. OLTC operations following a fault and permanent trip of two lines 100-101 in Figure 7.11, for the cases with synchronous machine DG.

Figure 7.20 indicates that the presence of synchronous DG on various operating modes has successfully restored the substation secondary bus voltages (back within the OLTC operating voltage range). This restoration can not be achieved when the DG is not present. Furthermore, the substation primary voltage has also been restored back within the allowed voltage range (between 0.94 pu minimum allowed voltage and 1.05 pu maximum allowed voltage, as specified in Section 3.5) with the presence of synchronous DG, except when the synchronous DG operates at a unity pf.

Based on the explanation above, it can be concluded that the presence of synchronous DG increases the long-term large-disturbance voltage stability margin. The maximum improvement will be obtained when the DG operates at a constant voltage.

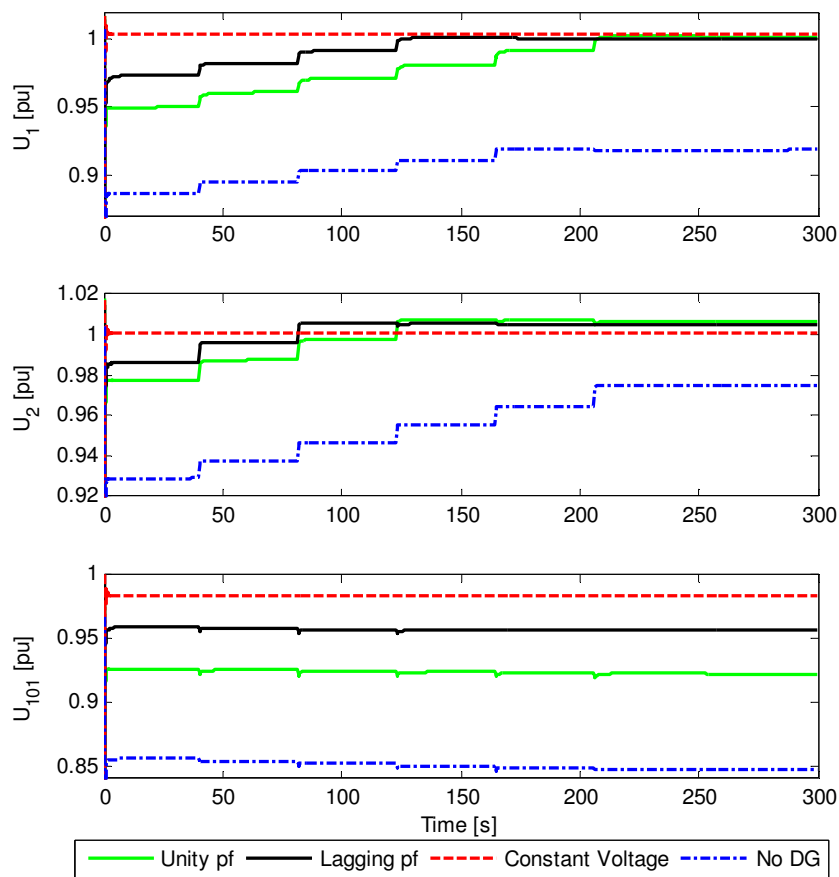

Figure 7.20. Substation bus voltages following a fault and permanent tripping of two 100-101 in Figure 7.11, for the cases with synchronous machine DG.

DG operation at a constant pf and at a constant voltage will have different impact on the improvement. This is because the electrical distance between the distribution system and the grid increases with the tripping of the line. It means that when the synchronous DG operates at a constant voltage, the synchronous DG will generate more reactive power (in the steady state after the disturbance) in order to bring its terminal voltage back to the pre-disturbance value. On the other hand, when the synchronous DG operates at a constant pf, the synchronous DG will generate reactive power as much as it generated before the disturbance. Therefore, a lower voltage will be resulted.

Induction Machine DG

The voltage at some buses and DG dynamic performance following a single-phase to ground fault and trip of two lines 100-101, in the presence of induction DG with normal size of shunt capacitor compensation, is shown in Figure 7.21. The figure shows that the disturbance causes a voltage collapse within less than 3s, if the induction DGs are not immediately disconnected. The scenario to the voltage collapse can be explained from Figure 7.21. The DG speed continuously increases after the fault because the induction DG does not have enough deceleration torque when the fault is cleared. This increases the reactive power consumption of the generator, which will not only depress the generator terminal voltage, but also the voltages in the whole system.

The OLTC operations and the substation voltages following the disturbance, for the cases *Larger C* and *Larger C + STATCOM* are presented in Figure 7.22 - Figure 7.23. Figure 7.23 indicates that, with these compensations, the presence of the induction DG increases the long-term large-disturbance voltage stability margin.

The results in Figure 7.22 - Figure 7.23 are obtained by keeping the DG to generate a constant power of 4 MW during the 300s observation period. A squirrel cage induction generator based wind power unit that generates constant power in 300s may be unrealistic. However, this approximation is enough to consider the impact of induction DG to long-term large-disturbance voltage stability.

Now consider the substation voltages for the case *Larger C + STATCOM* in Figure 7.23. The steady state voltage at bus-101 (U_{101}) and bus-1 (U_1) before the first operation of the OLTC is 0.954 and 0.996 pu, respectively. With $U_{102} > U_{101}$, and with the STATCOMs keeping the steady state voltage

at bus-3 and bus-9 constant at 0.985 pu, all voltages in the system will be higher than the minimum allowed voltage 0.94 pu.

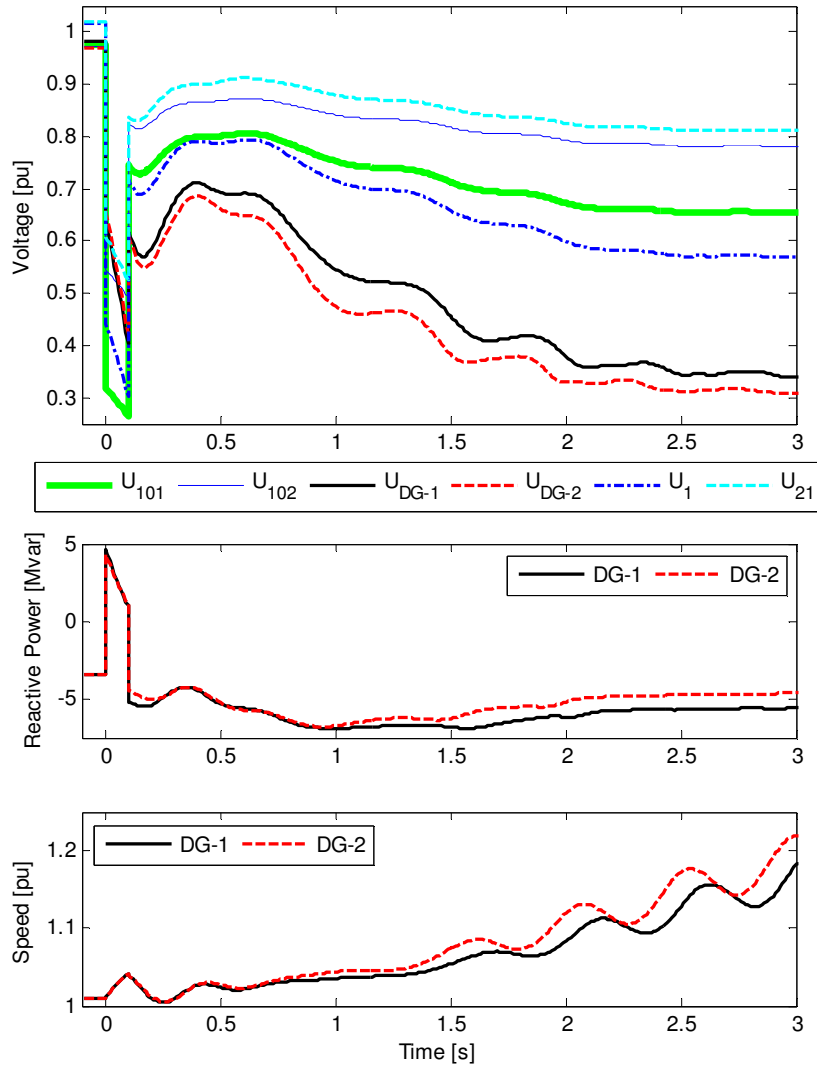

Figure 7.21. Voltage, DG reactive power and DG speed following a fault and trip of two lines 100 -101 in Figure 7.11, for the case of induction machine DG with normal compensation.

On the other hand, it is shown in Figure 7.23 that U_{101} after 300s (in the steady state after the completion of the OLTC operations) is 0.929 pu. When the objective of the voltage restoration is to keep the voltage at all buses within the allowed range (between 0.94 and 1.05 pu), as in this particular case, blocking the OLTC operation is better. In some references, blocking the OLTC operation for this kind of disturbances has been suggested to prevent voltage instability [29], [75].

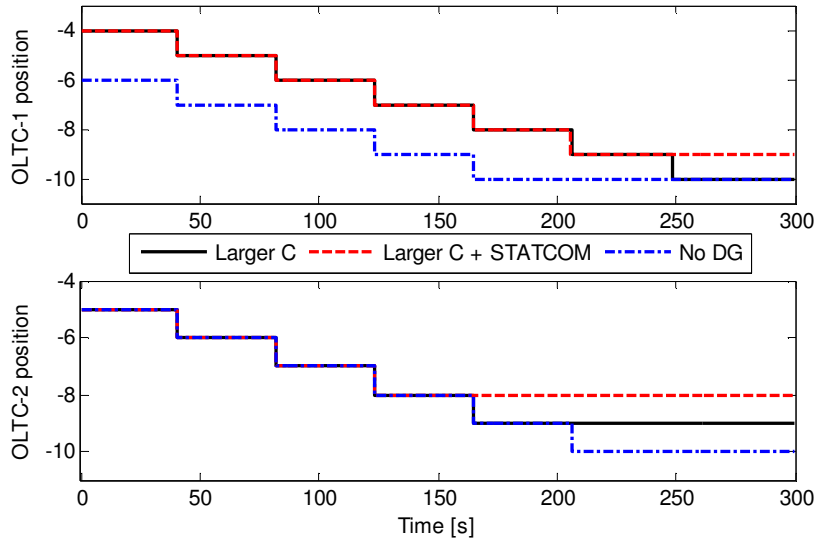

Figure 7.22. OLTC operations following a fault and permanent trip of two lines 100-101 in Figure 7.11 , for the cases with induction machine DG.

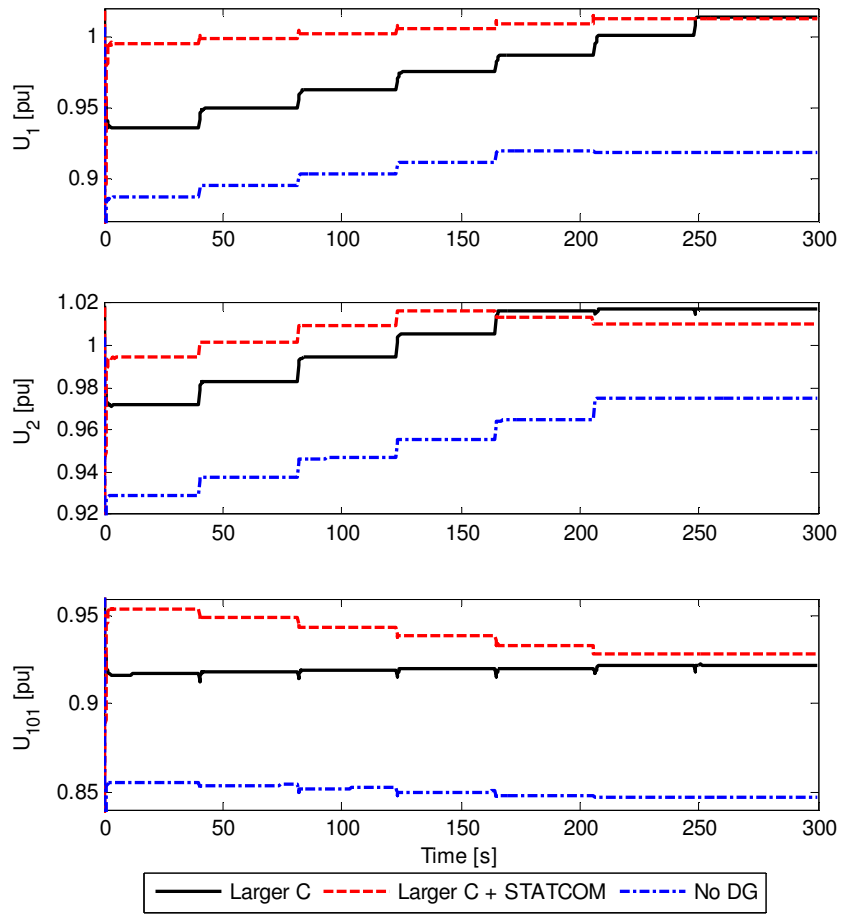

Figure 7.23. Substation bus voltages following a fault and permanent trip of two lines 100-101 in Figure 7.11, for the cases with induction machine DG.

7.4.3 DG Impact on Long-Term Small-Disturbance Voltage Stability

PV curves to investigate the impact of synchronous DG and induction DG on long-term small-disturbance voltage stability are shown in Figure 7.24. The curves indicate that the synchronous DG will always increase the stability margin, where the increase will be higher when the synchronous DG operates in voltage control mode. On the other hand, induction DG is shown to decrease the stability margin, except for the case *larger C + STATCOM*. These phenomena can be simply explained from the active and reactive power transmission and the importance of providing reactive power locally, which has been explained in Section 6.2.

For the cases with synchronous DG, the active and reactive power generated by the DG has decreased the active and reactive power transmission. Therefore, larger load can be served. As the synchronous DG generates the same amount of active power in all cases, the case where the DG generates (or is able to generate) higher reactive power will result in a larger maximum load (the load that causes voltage instability).

For the cases with induction DG, though the active power generated by the DG has decreased the active power transmission, but the DG absorbing reactive power has, however, increased the reactive power transmission. On the other hand, as has been explained in Section 6.2, transmitting a large amount of active power over a long distance is, to some extent, no problem, but transmitting a large amount of reactive power over a long distance is really a problem. Hence, the negative impact from the DG absorbed reactive power is more dominant than the positive impact from the DG generated reactive power.

The increase of the maximum load that can be gained by increasing the size of the capacitor compensation is less effective due to the characteristic of a shunt capacitor where its reactive power output is proportional to the square of the voltage. Hence, the capacitor reactive power output decreases significantly when the voltage decreases due to the load increase. A reactive power compensation device where the reactive power output is linearly proportional to the voltage, like a STATCOM, is shown to give a more significant increase.

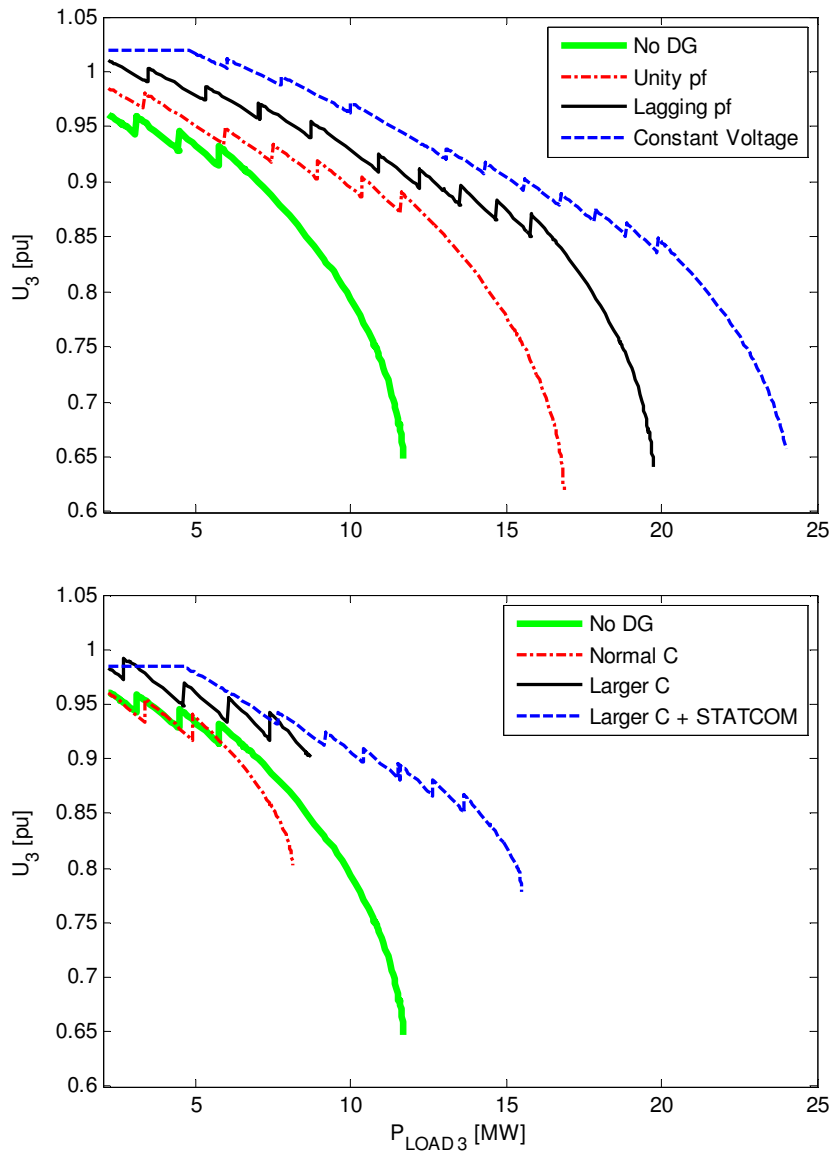

Figure 7.24. PV curves for load increase at bus-3 in the presence of synchronous DG (upper plot) and induction DG (lower plot).

7.5 Conclusions

In this chapter, voltage stability in the presence of synchronous machine DG and induction machine DG has been investigated. Different possible synchronous DG and induction DG operating conditions and their impact on different voltage instability mechanisms have been evaluated.

It is shown that synchronous DG has a potential benefit in increasing the voltage stability margin, for all kinds of voltage instability mechanisms. Different factors contribute significantly to different kinds of voltage stability. Fast response from a synchronous DG exciter will ensure fast voltage recovery. This will significantly improve the transient voltage stability. DG operation at a constant voltage keeps the distribution system voltages high when major transmission lines trip. This will enhance the long-term large-disturbance voltage stability. For the long-term small-disturbance voltage stability, the larger reactive power that the DG generates (or is able to generate) the larger the maximum load (the load that causes voltage instability) is.

It has also been indicated that voltage stability can be a major problem in a distribution system with a high penetration of induction DG. In most cases, the voltage stability margin decreases with the presence of induction DG. In a certain case, a long-term voltage instability problem may become a transient voltage instability problem with the presence of induction DG, where the voltage can collapse within a few seconds. This can happen if, for example, the induction DG does not have enough deceleration torque following the trip of major transmission lines. However, if the trip does not make the induction DG to be unstable, due to supports from the DG reactive power compensation device, the induction DG may even improve long-term large-disturbance voltage stability.

In all cases, the decrease of the voltage stability margin is due to the behavior of the induction DG. The induction DG absorbs reactive power in normal operating condition and absorbs a larger amount of reactive power immediately after the fault. Hence, reactive power compensation is the key factor in mitigating the voltage stability problems caused by induction DG. The larger the reactive power compensation, the more deterioration can be deferred (or the more improvement can be gained).

Nevertheless, excessive compensation will increase losses and may cause overvoltage. In this case, a reactive power device with a continuous control, rather than in a stepwise manner, will be better. Further, the voltage in the system will decrease significantly during and immediately after a fault. In this case, capacitor based reactive power devices need a larger size than converter based reactive power devices, in order to get the same level of compensation.

Chapter 8

Conclusions and Future Work

This chapter provides the conclusions of the work and some suggestions for further research related to the operation and control of power distribution systems in the presence of distributed generation.

8.1 Conclusions

Distributed Generation (DG – small-scale generation, connected to local distribution systems) is gaining more and more attention world wide as an alternative to centralized large generating stations. The increasing integration of DG in power distribution systems has raised many considerations and challenges on the operation and control of power distribution systems.

The aim of this thesis is to investigate voltage control and voltage stability in distribution systems in the presence of synchronous machine and induction machine based DG. The results show that DG can have a positive or negative impact on the steady state voltage and reactive power control as well as on the voltage stability margin in distribution systems. The type and the operation characteristics of the DG affect the controllability. However, if the DG is properly coordinated with the available voltage and reactive power equipment, a proper voltage regulation can still be maintained with the presence of DG. Further, the negative impact of DG on voltage stability can be mitigated with proper reactive power compensation devices.

A general overview of various DG technologies has been given in Chapter 2. The potentials, challenges, sizes and power output characteristics of each technology have been addressed. It has been shown that a number of DG technologies are in a position to compete with centralized large generating stations. Some DG has dispatchable power output, similar to centralized generating stations, and some DG technologies generate non dispatchable power output. Non-dispatchable units are normally the ones driven by renewable energy sources.

The steady state voltage and reactive power control in *conventional distribution systems* (distribution systems without DG) has been discussed in Chapter 3. It has been shown that, as the voltage profiles in conventional distribution systems decrease towards the ends of the feeders, the steady state voltage is mainly regulated to counteract the voltage drop. On-load tap-changers (OLTC), substation shunt capacitors and feeder shunt capacitors are widely used as the voltage and reactive power control equipment. Keeping the steady state voltage within the allowed range all the time as the constraints and minimizing energy losses in a considerably long period as the objective, the voltage and reactive power control equipment can be operated locally based on pre-determined local control set points (*local voltage and reactive power control*).

The local voltage and reactive power control in the presence of DG has been presented in Chapter 4. It has been indicated that the presence of DG needs to be coordinated with the available voltage and reactive power control equipment, in order to ensure that the steady state voltages can be maintained within the allowed range all the time, as well as to decrease losses. Further, it has also been shown that a synchronous machine DG operating either at unity pf, lagging pf, or constant voltage will reduce the voltage change due to the load change. The operation at a constant voltage will result in the highest reduction, which is beneficial.

The coordinated voltage and reactive power control based on forecasting, optimization and remote control (*coordinated control*), in the presence of DG, has been proposed in Chapter 5. It has been indicated that the presence of induction machine DG increases the risk of undervoltage/overvoltage, though the DG will not interfere with the effectiveness of the OLTC operation. The coordinated control has been shown to mitigate the risk of undervoltage/overvoltage and to minimize losses. Further, it has also been illustrated that, by involving the DG in the coordinated voltage control; the reactive power from the available capacitors can be maximally used for both economic operation and secure operation purposes.

The analysis of voltage stability in conventional distribution systems has been carried out in Chapter 6. Different voltage instability mechanisms have been evaluated. Minimizing reactive power flow to the distribution systems by using shunt capacitors is indicated not only beneficial in minimizing losses but also in increasing the maximum transfer capability to the distribution systems. The type of reactive power compensation needed to mitigate voltage instability or to increase the voltage stability margin is shown to depend on the type of voltage stability. Mechanically switched shunt capacitors are able to mitigate the long-term voltage instability but are too slow to mitigate the

transient voltage instability. In this case, dynamic reactive power devices are needed.

Finally, the voltage stability in the presence of DG has been investigated in Chapter 7. It has been indicated that voltage stability can be a major problem in distribution systems with a high penetration of induction machine DG. On the other hand, the synchronous machine DG generating reactive power or not exchanging reactive power will increase the voltage stability margin. Further, it has also been illustrated that the voltage stability problem in the presence of induction DG can be mitigated by providing the induction DG with dynamic voltage and reactive power devices.

8.2 Future Work

The local voltage and reactive power control and the coordinated voltage and reactive power control in the presence of DG has been investigated in Chapter 4 and Chapter 5, respectively. For, the local voltage and reactive power control in Chapter 4, the voltage and reactive power control practices in conventional distribution systems are adopted. On the other hand, the coordinated voltage and reactive power control in Chapter 5 adopts the voltage and reactive power control practices in transmission systems. An improvement is obtained by the adoption of the transmission system voltage and reactive power control practices.

A similar approach can be implemented to analyze the protection coordination in the presence of DG. Firstly, common protection practices in conventional distribution systems can be studied with DG present. Then, the implementation of the protection coordination practices in interconnected transmission systems to the distribution systems with DG present can be examined. Similarly, an improvement can be expected by the adoption of the transmission system protection practices.

Further, the voltage stability in the presence of DG has been presented in Chapter 7. For the completeness of the stability analysis, the work can be continued by investigating the rotor angle stability and the frequency stability in the presence of DG.

Furthermore, with the increase of the penetration and the importance of DG, it is also necessary to assess DG in islanding operation and DG with power frequency control. Again, the islanding operation and power frequency balance can adopt the islanding operation and power frequency balance practices in large centralized stations (transmission systems). Such work on the islanding operation and the power frequency balance can be the continuation of the frequency stability study.

References

- [1] A.R. Bergen and V. Vittal, *Power System Analysis*, Prentice Hall, 2000.
- [2] “Kyoto Protocol to the United Nations Framework Convention on Climate Change”. Available at <http://unfccc.int/resource/docs/convkp/kpeng.html>, last accessed 26 September 2007.
- [3] CIRED preliminary report of CIRED Working Group 04, “Dispersed Generation”. Issued at the CIRED Conference in Nice, June 1999.
- [4] A. Schweer, “Special Report Session 3”, in *Proc. of CIGRE Symposium on Impact of demand side management, integrated resource planning and distributed generation*, Neptun, Romania, 1997.
- [5] A.J. Petrella, “Issues, impacts and strategies for distributed generation challenged power systems”, in *Proc. of CIGRE Symposium on Impact of demand side management, integrated resource planning and distributed generation*, Neptun, Romania, 1997.
- [6] A. Borbely and J.F. Kreider, *Distributed Generation: A New Paradigm for the New Millenium*, CRC Press, 2001.
- [7] IEA, *Distributed Generation in Liberalised Electricity Markets*, International Energy Agency, France, 2002.
- [8] IEA, *Renewables for Power Generation: Status and Prospects*, International Energy Agency, France, 2003.
- [9] N. Jenkins, R. Allan, P. Crossley, D. Kirschen, G. Strbac, *Embedded Generation*, The Institution of Electrical Engineers, London, 2000.
- [10] T.A. Short, *Electric Power Distribution Handbook*, CRC Press LLC, 2004.
- [11] T. Gönen, *Electric Power Distribution System*, McGraw-Hill Book Company, 1986.
- [12] J.A. Oliver, “Generation Characteristics Task Force, CIGRE, Study Committees 11, 37, 38 and 39”, *Electra*, no. 185, pp. 15 – 33, August 1999.
- [13] N. Jenkins, “Embedded Generation Tutorial”, *Power Engineering Journal*, pp. 145 – 150, June 1995.
- [14] D.S. Henderson, “Synchronous or Induction Generators? – The Choice for Small Scale Generation”, in *Proc. of Opportunities and Advances in International Power Generation*, 1996.
- [15] M.W. Davis, “Microturbines – an economics and reliability evaluation for commercial, residential and remote load applications”, *IEEE Transaction on Power Systems*, vol. 14, no. 4, pp. 1556-1562, 1999.

- [16] M.R. Patel, *Wind and Solar Power Systems*, CRC Press LCC, 1999.
- [17] IEA, *Renewables for Power Generation: Status and Prospects*, International Energy Agency, France, 2003.
- [18] EWEA, “EWEA 2006 Annual Report”, The European Wind Energy Association, 2007. Available at http://www.ewea.org/fileadmin/ewea_documents/documents/publications/reports/ewea-report2006.pdf, last accessed on 22 September 2007.
- [19] EWEA, “Wind Power Technology”, The European Wind Energy Association, 2004. Available at http://www.ewea.org/fileadmin/ewea_documents/documents/publications/factsheets/factsheet_technology2.pdf, last accessed on 22 September 2007.
- [20] IEA, *Renewable Energy, Market and Policy Trends in IEA Countries*, International Energy Agency, France, 2004.
- [21] ESHA, “European Renewable Energy Review 2006”, European Small Hydropower Association, 2007. Available at http://www.esha.be/fileadmin/esha_files/documents/publications/articles/ERER2006-Final.pdf, last accessed on 22 September 2007.
- [22] S. Rahman, “Green Power: What is and Where We Can Find It?” *IEEE Power and Energy Magazine*, vol. 1, pp. 30-37, January - February 2003.
- [23] IEA, “Biomass for Power Generation and CHP”, International Energy Agency, 2007. Available at <http://www.iea.org/textbase/techno/essentials3.pdf>, last accessed on 22 September 2007.
- [24] S. Sheth and M. Shahidehpour, “Tidal Energy in Electric Power Systems”, in *Proc. of IEEE Power Engineering Society General Meeting*, 2005.
- [25] R. Dettmer, “Wave Energy Gets Seaworthy”, *IEE Review*, September 2002.
- [26] M. Leijon, H. Bernhoff, O. Ågren, J. Isberg, J. Sunberg, M. Berg, K.E. Karlsson and A. Wolfbrandt, “Multiphysics Simulation of Wave Energy to Electric Energy Conversion by Permanent Magnet Linear Generator”, *IEEE Transactions on Energy Conversions*, vol. 20, no.1, March 2005.
- [27] Uppsala Universitet, “Wave Power Project – Islandsberg”. Available at http://www.el.angstrom.uu.se/meny/eng/index_E.html, last accessed on 7 January 2008.
- [28] M. Thomson, “Automatic voltage control relays and embedded generation. Part I”, *Power Engineering Journal*, vol. 14, pp. 71 – 76, April 2000.
- [29] C.W. Taylor, *Power System Voltage Stability*, Mc Graw Hill, 1994.
- [30] T.S. Abdel Salam, A.Y. Chikhani and R. Hackam, “A New Technique for Loss Reduction Using Compensating Capacitors Applied to Distribution System

-
- Varying Load Condition”, *IEEE Transactions on Power Delivery*, vol. 9, no. 2, April 1994.
- [31] M.Y. Cho and Y.W. Chen, “Fixed/Switched Type Shunt Capacitor Planning of Distribution Systems by Considering Customer Load Patterns and Simplified Feeder Model”, *IEE Proc.-Gener, Transm, Distrib.*, vol. 144, no. 6, November 1997.
- [32] B. Milosevic and M. Begovic, “Capacitor Placement for Conservative Voltage Reduction on Distribution Feeders,” *IEEE Transactions on Power Delivery*, vol. 19, no. 3, July 2004.
- [33] I. Roytelman and V. Ganesan, “Coordinated Local and Centralized Control in Distribution Management Systems”, *IEEE Transactions on Power Delivery*, vol. 15, no. 2, April 2000.
- [34] V. Borozan, M.E. Baran and D. Novosel, “Integrated Volt/Var Control in Distribution Systems”, in *Proc. of IEEE Power Engineering Society Winter Meeting*, 2001.
- [35] A. Augugliaro, L. Dusonchet, S. Favuzza and E.R. Sanseverino, “Voltage Regulation and Power Losses Minimization in Automated Distribution Networks by an Evolutionary Multiobjective Approach”, *IEEE Transactions on Power Systems*, vol. 19, no.3, August 2004.
- [36] Z. Hu, X. Wang, H. Chen and G.A. Taylor, “Volt/VAr Control in Distribution Systems Using a Time-Interval Based Approach”, *IEE Proc.-Gener, Transm, Distrib.*, vol. 150, no. 5, September 2003.
- [37] R.H. Liang and C.K. Cheng, “Dispatch of Main Transformer ULTC and Capacitors in a Distribution System”, *IEEE Transaction on Power Delivery*, vol. 16, No. 4, October 2001.
- [38] S. Civanlar and J.J. Grainger, “Forecasting Distribution Feeder Loads: Modelling and Application to Volt/VAr Control”, *IEEE Transaction on Power Delivery*, vol. 3, no. 1, January 1988.
- [39] T. Senjyu, H. Takara, K. Uezato and T. Funabashi, “One-Hour-Ahead Load Forecasting Using Neural Network”, *IEEE Transaction on Power Systems*, vol. 17, no.1, February 2002.
- [40] J.J. Paserba, D.J. Leonard, N.W. Miller, M.G. Laurby, S.T. Naumann and F.P. Sener, “Coordination of a Distribution Level Continuously Controlled Compensation with Existing Substation Equipment for Long Term VAR Management”, *IEEE Transaction on Power Delivery*, vol. 9, no. 2, April 1994.
- [41] S. Repo, H. Laaksonen, et. al. “A Case Study of Voltage Rise Problem due to a Large Amount of Distributed Generation on a Weak Distribution Network,” in *Proc. of IEEE PowerTech Conference*, 2003.

- [42] P. Brady, C. Dai and Y. Baghzouz, "Need to Revise Switched Capacitor Controls on Feeders with Distributed Generation," in *Proc. of IEEE Transmission and Distribution Conference and Exposition*, 2003.
- [43] L.A. Kojovic, "The Impact of Dispersed Generation and Voltage Regulator Operations on Power Quality", in *Proc. of CIGRE Symposium on Power Systems with Dispersed Generation*, 2005.
- [44] C.L. Masters, "Voltage Rise, the Big Issue When Connecting Embedded Generation to Long 11 kV Overhead Lines", *Power Engineering Journal*, vol.16, pp. 5-12, Feb. 2002.
- [45] C.M. Hird, H. Leite, N. Jenkins and H. Li, "Network Voltage Controller for Distributed Generation", *IEE Proc.-Gener, Transm, Distrib.*, vol. 151, no. 2, March 2004.
- [46] J.H. Choi and J.C. Kim, "Advanced Voltage Regulation Method of Power Distribution Systems Interconnected with Dispersed Storage and Generation Systems", *IEEE Transactions on Power Delivery*, vol. 16, no. 2, pp. 329-334, April 2001.
- [47] W. Freitas, J.C.M. Vieira, A. Morelato, L.C.P. da Silva, V.F. da Costa and F.A.B. Lemos, "Comparative Analysis Between Synchronous and Induction Machines for Distributed Generation Applications", *IEEE Transaction on Power Systems*, vol. 21, no. 1, February 2006.
- [48] C.W. Taylor, "Line drop compensation, high side voltage control, secondary voltage control – why not control a generator like a static var compensator?", in *Proc. of IEEE Power Engineering Society Summer Meeting*, 2000.
- [49] S. Corsi, P. Marannino, N. Losignore, G. Moreschini and G. Piccini, "Coordination Between the Reactive Power Scheduling Function and the Hierarchical Voltage Control of the EHV Enel System", *IEEE Transactions on Power Systems*, vol. 10, no. 2, May 1995.
- [50] H. Vu, P. Pruvot, C. Launay and Y. Harmand, "An Improved Voltage Control on Large-Scale Power System", *IEEE Transactions on Power Systems*, vol. 11, no. 3, August 1996.
- [51] B. Cova, N. Losignore, P. Marannino and M. Montagna, "Contingency Constrained Optimal Reactive Power Flow Procedures for Voltage Control in Planning and Operation", *IEEE Transactions on Power Systems*, vol. 10, no. 2, May 1995.
- [52] C.M. Affonso, L.C.P. da Silva, F.G.M Lima and S. Soares, "MW and MVar Management on Supply and Demand Side for Meeting Voltage Stability Margin Criteria", *IEEE Transactions on Power Systems*, vol. 19, no. 3, August 2004.

-
- [53] J. Park, S. Nam and J. Park, "Control of a ULTC Considering the Dispatch Schedule of Capacitors in a Distribution System", *IEEE Transactions on Power Systems*, vol. 22, no. 2, May 2007.
- [54] R. Doherty and M. O'Malley, "A New Approach to Quantify Reserve Demand in Systems With Significant Installed Wind Capacity", *IEEE Transaction on Power Systems*, vol. 20, no. 2, May 2005.
- [55] G.N. Kariniotakis, G.S. Stavrakakis and E.F. Nogaret, "Wind Power Forecasting Using Advanced Neural Networks Models", *IEEE Transaction on Energy Conversion*, vol. 11, no. 4, December 1996.
- [56] IEEE/CIGRE Joint Task Force on Stability Terms and Definitions, "Definition and Classification of Power System Stability", *IEEE Transactions on Power Systems*, vol. 19, no. 2, May 2004.
- [57] P. Kundur, *Power System Stability and Control*, McGraw-Hill, Inc., New York, 1993.
- [58] G. Andersson, et. al., "Causes of the 2003 Major Grid Blackouts in North America and Europe, and Recommended Means to Improve System Dynamic Performance", *IEEE Transactions on Power Systems*, vol. 20, no. 4, November 2005.
- [59] CIGRE Task Force 38-02-10, *Modelling of Voltage Collapse Including Dynamic Phenomena*, 1993.
- [60] A.E. Hammad and M.Z. El Sadek, "Prevention of Transient Voltage Instabilities due to Induction Motor Loads by Static VAR Compensators", *IEEE Transactions on Power Systems*, vol. 4, no. 3, August 1989.
- [61] R. M. Mathur and R.K. Varma, *Thyristor-Based FACTS Controllers for Electrical Transmission Systems*, A John Wiley & Sons, Inc. Publication, 2002.
- [62] N.G. Hingorani and L. Gyugyi, *Understanding FACTS. Concept and technology of Flexible AC Transmission System*. New York: IEEE Press, 2000.
- [63] CIGRE Publication No. 144, STATIC Synchronous Compensator (STATCOM), Working Group 14.19, edited by I.A: Erimez and A.M. Foss, August 2000.
- [64] K.M. Son, K.S. Moon, S. K. Lee and J.K. Park, "Coordination of an SVC with a ULTC Reserving Compensation Margin for Emergency Control", *IEEE Transactions on Power Delivery*, vol. 15, no. 4, October 2000.
- [65] M.H. Abdel-Rahman, F.M.H. Youssef and A.A. Saber, "New Static Var Compensator Control Strategy and Coordination with Under-Load Tap Changer", *IEEE Transactions on Power Delivery*, vol. 21, no. 3, July 2006.
- [66] DIgSILENT PowerFactory, www.digsilent.de.

- [67] D. Karlsson, *Voltage Stability Simulations Using Detailed Models Based on Field Measurements*, PhD Thesis, Technical Report No 230, Chalmers University of Technology, Sweden, 1992.
- [68] W. Freitas, J.C.M. Vieira, A. Morelato, and W. Xu, "Influence of Excitation System Control Modes on the Allowable Penetration Level of Distributed Synchronous Generators", *IEEE Transactions on Energy Conversion*, vol. 20, no. 2, June 2005.
- [69] *IEEE Recommended Practice for Excitation System Models for Power System Stability Studies*, IEEE Standard 421.5-1992.
- [70] A.D. Hansen, C. Jauch, P. Sørensen, F. Iov and F. Blaabjerg, "Dynamic wind turbine models in power system simulation tool DIGSILENT", Riso National Laboratory, Roskilde, Denmark, 2003. Available on-line at http://www.digsilent.de/Software/Application_Examples/ris-r-1400.pdf, last accessed December 24, 2007.
- [71] C.A. Gross, *Power System Analysis*, John Willey & Sons, New York, 1979.
- [72] O. Samuelsson and S. Lindahl, "On Speed Stability", *IEEE Transactions on Power Systems*, vol. 20, no. 2, May 2005.
- [73] F. Blaabjerg, Zhe Chen and S.B. Kjaer, "Power Electronics as Efficient Interface in Dispersed Power Generation Systems", *IEEE Transactions on Power Electronics*, vol. 19, no. 5, September 2004.
- [74] J.A.D. de Leon II and C.W. Taylor, "Understanding and Solving Short-Term Voltage Stability Problems", in *Proc. of IEEE Power Engineering Summer Meeting*, 2002.
- [75] M. Larsson, *Coordinated Voltage Control in Electric Power Systems*, PhD Thesis, Lund University, Sweden, 2000.

Biography

Ferry Viawan was born on August 12, 1974, in Banyuwangi, Indonesia. He obtained his B.Sc. degree in Electrical Engineering from Bandung Institute of Technology, Indonesia with honor (*cum laude*) in October 1996 and M.Sc. degree in Electric Power Engineering from Chalmers University of Technology, Sweden with honor (*distinction*) in December 2003. In January 2004, he started his PhD study at the Division of Electric Power Engineering, Department of Energy and Environment, Chalmers University of Technology, Sweden.

From December 1996 until October 2003, he worked as a power system engineer at Chevron, in Riau, Indonesia, where he worked on operation, planning and protection of a transmission and distribution system. Since February 2007, he has been working for Power System and Apparatus Group, Power Technologies Department, ABB Corporate Research, Västerås, Sweden.

Ferry is married with Ida Rose and at the moment they have a daughter, Kayyisah Amada.