

THESIS FOR THE DEGREE OF LICENTIATE OF ENGINEERING

# High Frequency Conducted Disturbances

Anna Tjäder



Department of Electric Power Engineering  
CHALMERS UNIVERSITY OF TECHNOLOGY  
Göteborg, Sweden, 2004

High Frequency Conducted Disturbances  
ANNA TJÄDER

© ANNA TJÄDER, 2004

**Technical Report no. 493L**

**School of Electrical Engineering**

**Chalmers University of Technology**

**ISSN 1651-4998**

Telephone: +46 (0)31 772 1630

Fax: +46 (0)31 772 1633

Email: [anna.tjader@elteknik.chalmers.se](mailto:anna.tjader@elteknik.chalmers.se)

Web: <http://www.elteknik.chalmers.se>

Chalmers Bibliotek, Reproservice  
Göteborg, Sweden, 2004

## **Abstract**

This thesis investigates power system transients. Voltage and current transients occur in the power system at all voltage levels and they can be caused by lightning somewhere in the system, by switching actions or by faults. Transient overvoltages and currents are quite unexplored areas, and the understanding of them is also rather limited. The thesis deals with low voltage conducted transient phenomena.

Measurements and simulations are performed with computers as load, and emphasis is laid on the initial transient behaviour of the energizing action. Measurements are also performed in different environments, such as households and office environments by investigating the apparatus normally used here.

A questionnaire was sent out to approximately 100 Swedish industrial companies inquiring about power quality issues, especially transient disturbances. The questionnaire included questions about estimated rate of occurrence for the transients and what kind of malfunctions can appear due to them.

The main contributions from this project were the measurements and simulation results obtained and the information collected by the survey. The measurements were taken both in a laboratory network with practically no other load present and an office network with mainly computer and lighting load. Transients were registered for the switching of one and two computers. The transient characteristics for the different cases were analysed to find out what affects the characteristics of the transient. The measurement results show that the energizing transient is may be severe for both networks.

However the presence of a second computer very close to the one being switched sometimes significantly reduces the severity of the energizing transient.

The results from the survey showed that quite a number of companies have problems with transients in their networks. These problems ranged from computer disturbances to processing interruptions. Most of the companies with problems seem to more or less accept them and get around them by regularly resetting a computer or replacing some electronics. Only a few of the companies perform measurements and try to solve the problems. This can be explained by the fact that the real costs due to the loss of production are not well known. In some cases a short transient disturbance of about half a second can cause a production outage for about eight hours. If those costs were better known more efforts would be used in finding a solution.

**Keywords:** power system transients, high frequency disturbances, power quality, electromagnetic compatibility, power system monitoring



## **Acknowledgements**

First, I would like to thank my supervisors Professor Jaap Daalder, who has supported me in the final part of the project and for making me believe in future research towards a Ph.D, and docent Math Bollen, who initiated the project and encouraged me during difficult parts of the work.

Many thanks to the members in my reference group, consisting of Evert Agneholm, ÅF Industri AB, Per Lindeberg, Göteborgs Hamn AB, and Sven-Erik Törnquist, Teknikföretagen AB, for valuable discussions and new ideas.

The project was funded by the Swedish Energy Agency, ABB AB, Alstom T&D, the Swedish Railway Company, the ÅF Research Foundation, and the Electric Power Utilities through the ELEKTRA program, and is gratefully acknowledged.

I would also like to thank Mikael Fröling for helping me with the English language and my contacts in the industry who generously helped me when I needed new inputs for the project.

I am grateful to my colleagues at the Department of Electric Power Engineering for creating a friendly working environment and for helping me out with all kinds of problems.

Finally, I would like to thank Mikael and Otto for their love and support and for always being there for me.



<b>Abstract</b> .....	<b>iii</b>
<b>Acknowledgments</b> .....	<b>v</b>
<b>Contents</b> .....	<b>vii</b>
<b>1 Introduction</b> .....	<b>1</b>
<b>1.1 Background</b> .....	<b>1</b>
<b>1.2 Origin of transients</b> .....	<b>2</b>
1.2.1 Current chopping .....	7
<b>1.3 Propagation of transients</b> .....	<b>9</b>
<b>1.4 Theory coupling transients</b> .....	<b>10</b>
1.4.1 Conductive coupling.....	10
1.4.2 Capacitive coupling – through the electric field.....	10
1.4.3 Inductive coupling – through the magnetic field.....	10
<b>1.5 Classification of transients</b> .....	<b>11</b>
1.5.1 Magnitude, duration and energy of transients .....	12
<b>1.6 Effects on equipment</b> .....	<b>13</b>
1.6.1 Capacitor switching problems .....	13
1.6.2 Other transients.....	13
1.6.3 Investigations and economical consequences.....	14
<b>1.7 Aim of the project</b> .....	<b>15</b>
<b>1.8 Contents of the thesis</b> .....	<b>16</b>
<b>2 Measurements and simulations</b> .....	<b>17</b>
<b>2.1 Background</b> .....	<b>17</b>
2.1.1 Measurements.....	17
2.1.2 Simulations.....	17
<b>2.2 Voltage measurements and simulations with one computer</b> .....	<b>17</b>
2.2.1 The laboratory supply network (strong system) .....	17
2.2.1.1 Measurements .....	18
2.2.1.2 Simulations.....	20
2.2.1.3 Comparison between measurements and simulations.....	24
2.2.2 Weak system, office supply network.....	26
2.2.2.1 Measurements .....	26
2.2.2.2 Simulations.....	27
2.2.2.3 Comparisons between measurements and simulations .....	29
<b>2.3 Voltage measurements and simulations of two computers</b> .....	<b>30</b>
2.3.1 Office supply network .....	30
2.3.1.1 Measurements .....	30
2.3.1.2 Simulations.....	31
2.3.1.3 Comparison between measurements and simulations.....	33
<b>2.4 Current measurements and simulations of one computer</b> .....	<b>33</b>
2.4.1 Laboratory supply network.....	33
2.4.1.1 Measurements .....	34
2.4.1.2 Simulations.....	35
2.4.1.3 Comparison between measurements and simulations.....	37
<b>2.5 Current measurements and simulations two computers</b> .....	<b>37</b>
<b>2.6 Conclusions</b> .....	<b>38</b>

<b>3</b>	<b>Field measurements.....</b>	<b>39</b>
3.1	<b>Background.....</b>	<b>39</b>
3.1.1	Measurements.....	39
3.2	<b>Measurements in domestic environment .....</b>	<b>39</b>
3.2.1	Kitchen measurements.....	39
3.2.2	Living room measurements .....	42
3.2.3	Basement measurements.....	42
3.2.4	Three phase measurement.....	44
3.2.5	Voltage transients in domestic environment, conclusions .....	44
3.3	<b>Measurements in official environment.....</b>	<b>45</b>
3.3.1	Office measurement.....	45
3.4	<b>Conclusions.....</b>	<b>46</b>
<b>4</b>	<b>Evaluation of questionnaire.....</b>	<b>47</b>
4.1	<b>Background.....</b>	<b>47</b>
4.2	<b>Introduction.....</b>	<b>47</b>
4.3	<b>Industrial power systems.....</b>	<b>47</b>
4.3.1	Lines of business .....	47
4.3.2	Contracted voltage levels.....	48
4.3.3	Load characteristics .....	49
4.3.4	Conductor systems.....	49
4.3.5	Redundancy and reserve power .....	50
4.4	<b>Power quality concerns.....</b>	<b>51</b>
4.4.1	Disturbances and interruptions .....	51
4.4.2	Lightning related problems.....	51
4.5	<b>Conclusions.....</b>	<b>53</b>
<b>5</b>	<b>Conclusions and future work .....</b>	<b>55</b>
5.1	<b>Conclusions.....</b>	<b>55</b>
5.2	<b>Future work.....</b>	<b>55</b>
	<b>References.....</b>	<b>57</b>
	<b>Appendix A.....</b>	<b>61</b>
	<b>Dranetz 658 Power Quality Monitor .....</b>	<b>61</b>
	Technical specifications.....	61
	<b>Instrument configuration for measurement.....</b>	<b>62</b>
	<b>Appendix B.....</b>	<b>63</b>
	<b>PSpice simulation program .....</b>	<b>63</b>
	<b>Parameters for the different networks .....</b>	<b>63</b>
	Laboratory network.....	63
	Office network.....	64
	<b>Appendix C.....</b>	<b>65</b>
	<b>The questionnaire in Swedish (Enkäten på Svenska).....</b>	<b>65</b>
	Elnätet.....	65
	Störningar/Avbrott.....	65



## Contents

---

Lasten.....	65
Förebyggande åtgärder mot störningar.....	66
<b>The questionnaire in English.....</b>	<b>66</b>
Electric power distribution .....	66
Disturbances/outages .....	67
Load situation .....	67
Preventive actions against disturbances.....	67
<b>Appendix D .....</b>	<b>69</b>
<b>PSpice A/D, Datasheet.....</b>	<b>69</b>

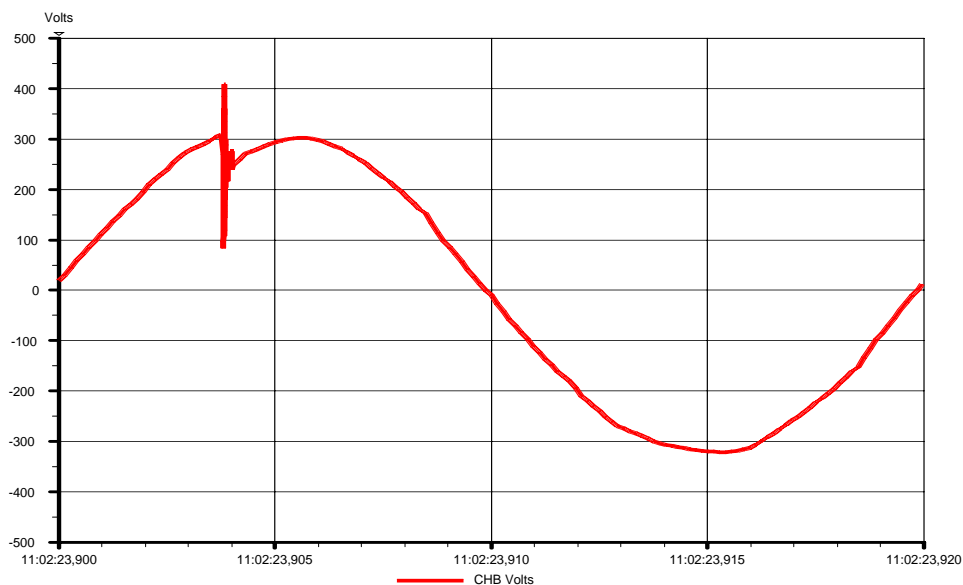


## 1 Introduction

### 1.1 Background

Many phenomena in the area of power quality are well investigated and much research has been performed on voltage dips, voltage unbalance and harmonics [25]. Transient overvoltages and currents are however quite unexplored areas, and the understanding of these phenomena is rather limited. One of the reasons for the lack of interest in transient phenomena is that there is often no clear connection between a specific transient and a resulting equipment mal-operation or damage. However, switching transients, lightning overvoltages, and capacitor energizing transients are known for their adverse effect on equipment [4]. High frequency disturbances are seen as a common source for unexplained spurious equipment trips. The lack of systematic prevention against transient disturbances is also a reason for research. There is enough circumstantial evidence to justify a further investigation into high-frequency disturbances.

Figure 1.1 shows a voltage transient due to computer switching in an office network. This is an ordinary type of switching transient in a low voltage network. The amplitude from a single switching action is rarely damaging, but sometimes several computers are switched on simultaneously and this may lead to very high amplitudes.



**Figure 1.1 Voltage transient due to computer switching**

The understanding of high frequency (HF) disturbances needs to be increased and the existing analysis tools need to be further developed. The EMC standards governing interaction between equipment and power system need also to be improved. A better understanding of HF disturbances is important when power lines are going to be used to transmit high-baud rate data. High

frequency disturbances are likely to increase in the future due to the installation of more power electronic equipment using faster switching devices, both in the power system and for end-user equipment. End-user equipment have become more sensitive to voltage disturbances, and investigations show that surface mounted components are more sensitive than traditional components, because of their simple construction with small inductance in the connecting wires that reduces their ability to absorb the energy.

Connections between power lines and communication lines is more and more common. In many homes there are no grounded power points where the personal computer is located. If the PC is connected to the telephone system by a modem this can lead to potential differences. When a short circuit occurs it can be hazardous for persons working with such a system. In an apartment block the fault can occur in one apartment; using the telephone line in another apartment can then be hazardous.

The load behaviour of common loads as computers has become more important the last years due to the fact that telephone lines and power lines are linked together with the use of fax machines and modems. The immunity and emission levels affect both the power system and the communication system.

Customers have become more intolerant to equipment mal-operation and disturbances in the power supply. This leads to high demands on equipment and supply. In the IEEE standard 1159:1995, discussed later on in this chapter the oscillatory transients are divided into low-, medium- and high-frequency transients - depending on the frequency range.

In this thesis 'high frequency' transients are defined as all transients with a frequency above 50/60 Hz. The measured transients have frequencies in the range of about 100 kHz.

## 1.2 Origin of transients

Transients in an electrical system can be generated by lightning, switching actions, or by faults. When lightning strikes a point, the voltage developed does the wave impedance as seen by the lightning current multiply the lightning discharge current. A lightning current rises to its peak in a time that varies from less than a microsecond to 10-20 microseconds and then decays to a small value close to zero within a few hundred microseconds. The small value of the current can remain in the system for some seconds [3]. The lightning induced transients can be caused by:

- Lightning strikes in the vicinity of the overhead lines, which do not hit the conductors.
- Direct lightning strikes to the line conductors injecting an electromagnetic wave into the line.
- Lightning strikes to the towers or to the shielding wires.

The switching transients are here divided into four groups:

- Capacitor energizing.
- Capacitor de-energizing.
- Inductor energizing.
- Inductor de-energizing.

The most severe situation from a power quality point of view, is capacitor energizing, while the other phenomena are not generating any severe transients.

The energizing of a capacitor bank leads to an initial change in the voltage waveform towards zero followed by an oscillation between  $L$  and  $C$  with a frequency of a few hundred Hertz. See figure 1.2. The step towards zero is due to the fact that  $u(t)$  is zero before the switch is closed.

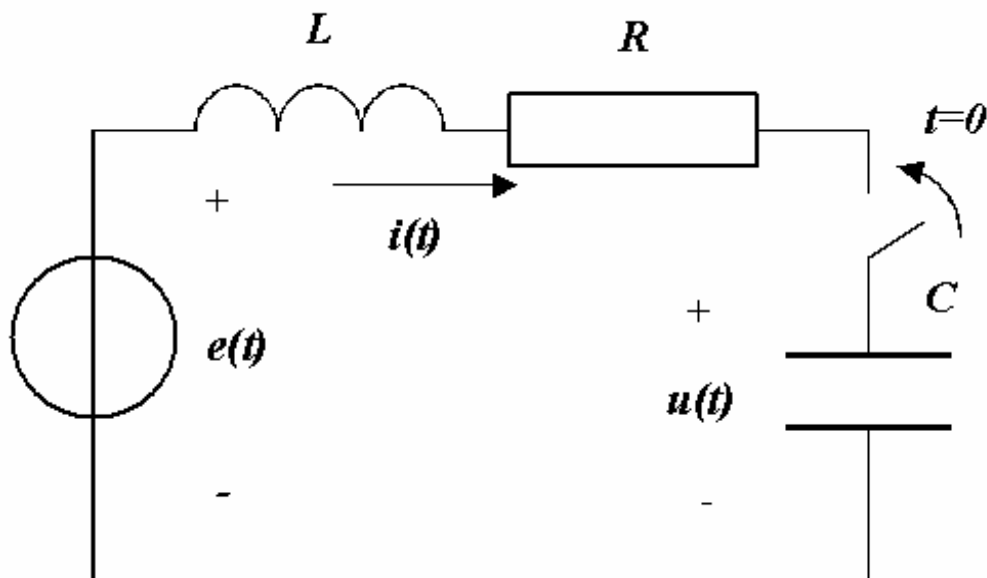
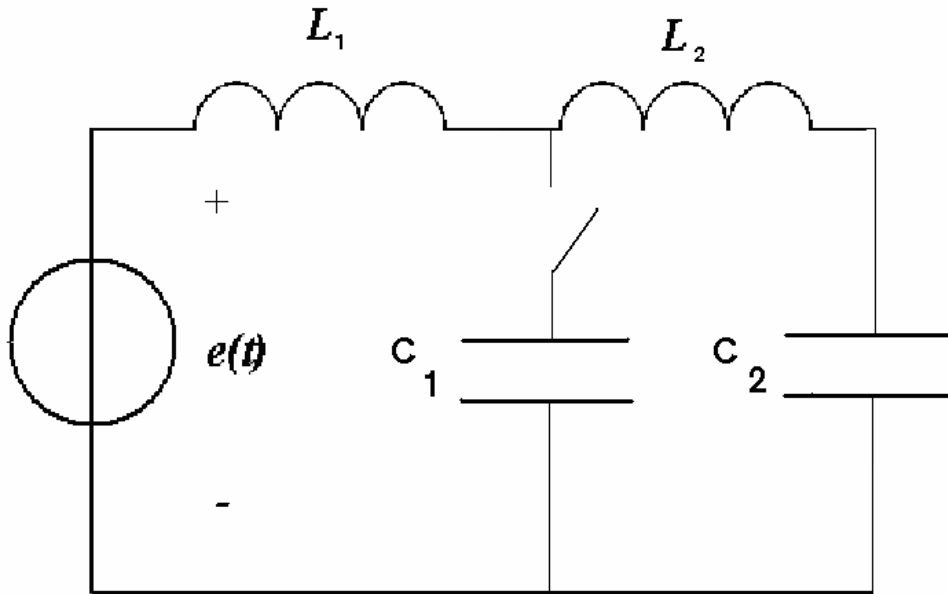


Figure 1.2 Capacitor energizing circuit

The presence of multiple capacitor banks may lead to more severe transients elsewhere in the system than at the terminals of the capacitor bank. This phenomenon is called voltage magnification and can lead to serious problems with the operation of equipment and even physical damage to equipment. The phenomenon can be explained by figure 1.3. The figure is simplified as the resistive load is not present.

$C_1$  is the capacitor being energized and  $C_2$  is a capacitor elsewhere in the system, typically at a lower voltage level. The impedance  $L_1$  represents the source impedance at the switching location and  $L_2$  represent the impedance between the switching location and the other capacitor, typically a

transformer. We assume that  $L_2$  and  $C_2$  do not affect the switching transient at the switching location.



**Figure 1.3 Voltage magnification circuit**

The result of the capacitor switching action will be a (damped) oscillation with an angular frequency equal to:

$$\omega_1 = \frac{1}{\sqrt{L_1 C_1}}$$

**Equation 1.1**

The voltage magnitude  $V_1$  is depending on the point-on-wave value when the switch is closed. The voltage over the capacitor  $C_2$ , i.e. the voltage at the other location, is found from the voltage divider equation:

$$V_2 = \frac{\frac{1}{j\omega_1 C_2}}{j\omega_1 L_2 + \frac{1}{j\omega_1 C_2}} V_1$$

**Equation 1.2**

The amplification factor is equal to:

$$\left| \frac{V_2}{V_1} \right| = \frac{1}{1 - \omega_1^2 L_2 C_2}$$

**Equation 1.3**

Using equation 1.1 we obtain the following expression:

$$\left| \frac{V_2}{V_1} \right| = \frac{1}{1 - \frac{L_2 C_2}{L_1 C_1}}$$

**Equation 1.4**

For a component ratio close to unity strong amplification occurs. The actual amplification is much less due to losses in the system and in the load connected to the system. There is also another reason why the transient cannot reach very high values. The impedance seen at any switching location is formed by the series connection of  $L_2$  and  $C_2$ . When the component ratio is close to unity, the impedance is close to zero, which will severely damp any oscillation at the switching location. In practice, voltages up to 4 p.u. have been measured [35].

The overvoltage can lead to incorrect tripping of adjustable speed drives [9]. Voltage transients can appear on a power line as a difference between the phase and neutral conductors, between the line and ground conductors, or between the neutral and ground conductors. An electromagnetic transient can be transmitted from the source to the system by conduction, induction and radiation. Measurements have shown that relatively small overvoltages lead to large overcurrents [16].

Figure 1.4 shows an example of voltage transients due to capacitor energizing. The main transient is in phase a (solid line), minor transients are visible in phase b (dashed line) and c (dotted line). The transient in phase a is due to the energizing of the phase-to-ground connected capacitor in that phase. The transients in the other two phases are due to mutual coupling between the phases.

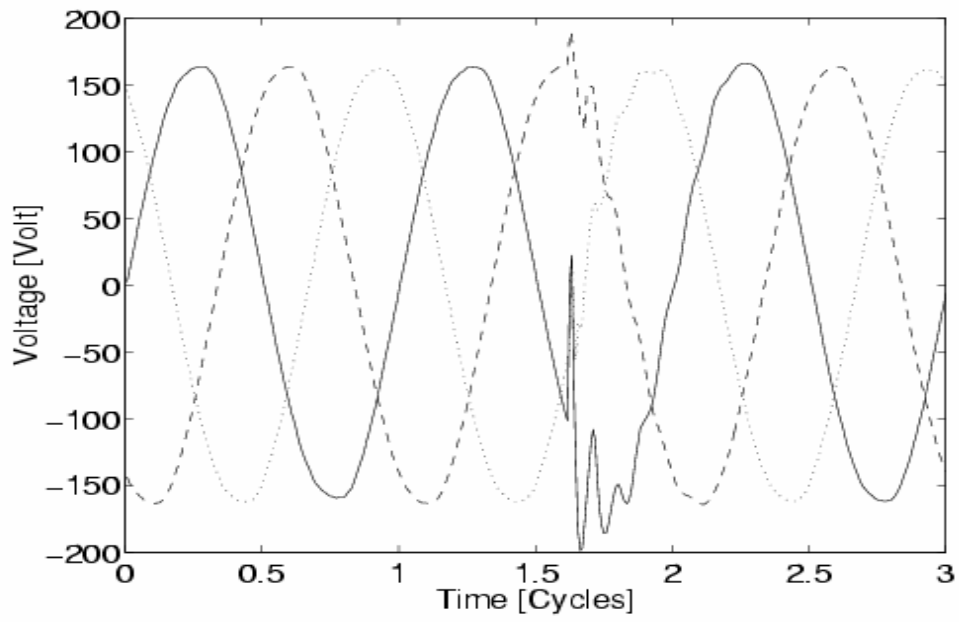


Figure 1.4 Voltage transient due to capacitor energizing



### 1.2.1 Current chopping

In an ac system the interruption of the current in a circuit breaker or switch occurs near or at the natural current zero. When contacts are separated an arc is formed between the contacts and provides for a medium in which the current is conducted.

The plasma generated by ionisation of the gas is a moderately good conductor at high currents. When the current approaches its zero value, the ionisation process diminishes as less energy is transferred to the arc and the conductance of the plasma becomes less. Generally the capability of an arc to conduct current ceases at a few amps and the arc extinguishes. The sudden decrease in current is called current chopping. In the common case of short circuit interruption this effect of current chopping is hardly of significance, see figure 1.5. As the current is high, the source inductance  $L$  has a low value. The time gradient of the current going to zero will then also be high and when the arc extinguishes it is very close to current zero, see figure 1.6. Once the arc is extinguished a voltage oscillation occurs due to the presence of  $L$  and  $C$ . This voltage is called the recovery voltage and its maximum value is twice the source voltage, see figure 1.7.

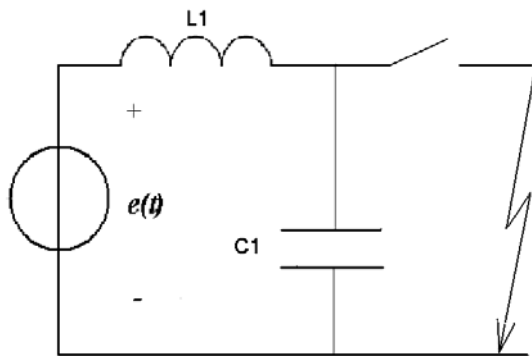


Figure 1.5 Current chopping circuit

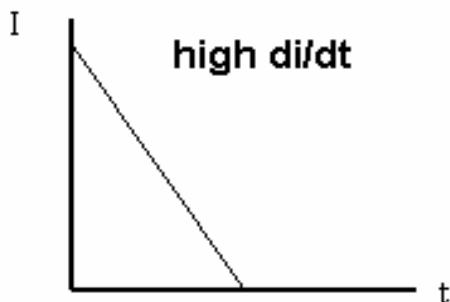


Figure 1.6 Current chopping

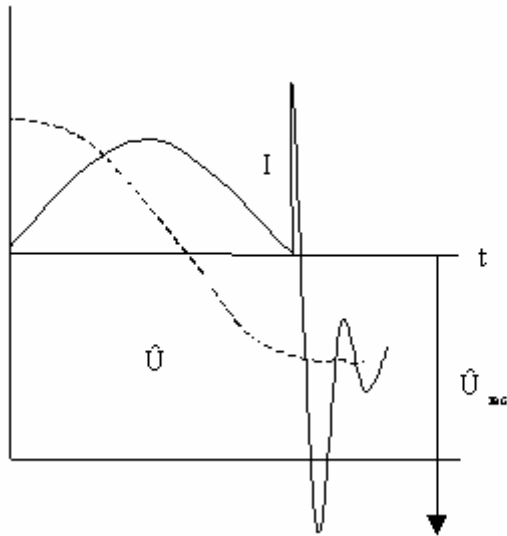


Figure 1.7 Current chopping, common case

However current chopping may lead to severe switching voltage transients in case the current is interrupted in a circuit where the inductive load is significant, see figure 1.8.

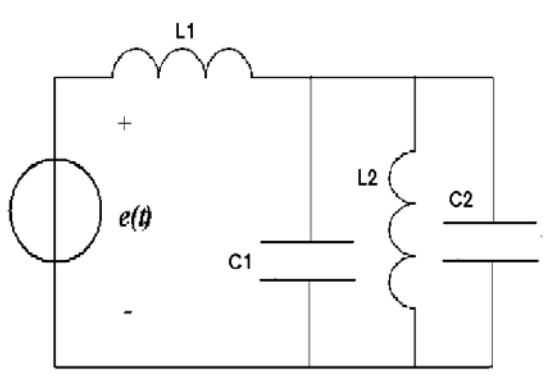


Figure 1.8 Current chopping with inductive load

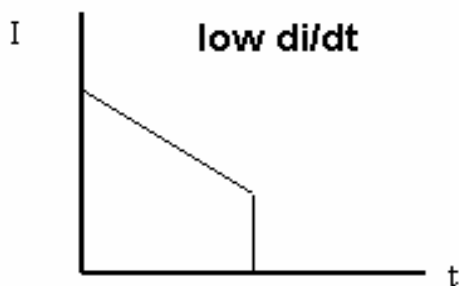
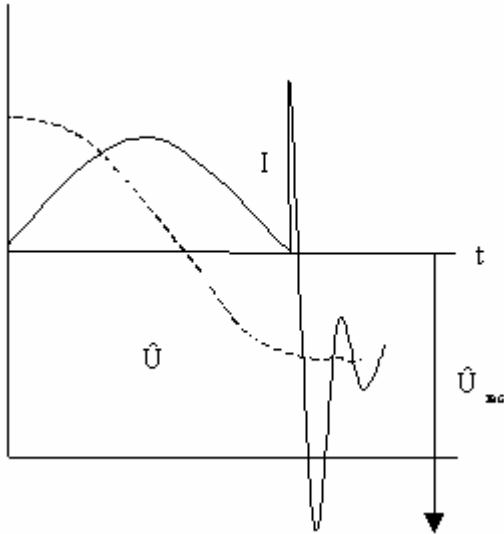


Figure 1.9 Current chopping



**Figure 1.10** Current chopping, severe case

In that case the currents to be interrupted will be low to moderate and the source inductance will have a high value. As the current now approaches current zero much slower, current chopping will occur before current zero, see figure 1.9. This in combination with the high value of the inductance  $L_1$  will generate a *higher* overvoltage as compared with the normal recovery voltage. Its max value is decided by:

$$U_{rec} = 2 \hat{U} + \sqrt{\frac{L}{C}} i_0$$

**Equation 1.5**

where  $i_0$  is the value of the chopped current. Also the load side may contribute in generating over voltages.

Current chopping may lead to damage of load and transformers or failure of circuit breakers.

### 1.3 Propagation of transients

If direct lightning strokes hit overhead power lines a transient voltage wave propagate along the line. The transient is transferred through the transformers and to the low-voltage system. The characteristics of the transformer and the impedance condition in the networks determine how the transients are propagated and how much the transient is damped along the way. The transients on power supply lines are also attenuated as the transients get divided into multiple parts at junctions. Measurements show less attenuation of slow-front transients than for fast-front surges as they propagate along a power line [7].

The characteristic impedance of a transmission line is  $Z_0 = \sqrt{L/C}$ , where L and C are the inductance and the capacitance of the transmission line per unit length respectively. In most practical examples the characteristic impedance of a transmission line is not the most important in the calculation of the damping of a transient. The frequency spectrum of the impulse, the line impedance at this frequency, the timing of the transient with respect to the phase angle of the fundamental voltage, all play an important role.

A transient impinging on a power line, even if it is unidirectional, excites the natural resonance frequencies of the system. As a result the transients are typically oscillatory, with different amplitudes and waveforms at different locations along the power distribution line. Most transients propagating in indoor low-voltage power supply lines show an oscillatory waveform [3].

Switching transient wave shapes and magnitudes depend upon the type of electrical circuit connected to it. Switching transients caused by semiconductor devices generate very fast transient voltages [2].

## 1.4 Theory coupling transients

### 1.4.1 Conductive coupling

Shared paths for signals, especially in the case of with high current, high current switching, or fast current transient signals, cause conductive coupling. There are ways to minimize this effect:

- Minimize sharing of return paths.
- Use lowest resistance for high currents and lowest inductance for high di/dt as practical for return paths.
- Increase rise and fall times.

### 1.4.2 Capacitive coupling – through the electric field

Capacitive coupling is the transfer of energy from one circuit to another by means of the mutual capacitance between the circuits. Fast voltage transients with high dv/dt cause capacitive coupling. Capacitive coupling is most common in high source impedance, high load impedance circuits. Capacitive coupling favours transfer of the higher frequency components of a signal. There are some methods to minimize capacitive coupling:

- Minimize line length and move lines farther apart.
- Use of electric field shields.
- Use shielded cable instead of twisted pairs.
- Increase rise and fall times.

### 1.4.3 Inductive coupling – through the magnetic field

Inductive coupling is the transfer of energy from one circuit to another by virtue of the mutual inductance between the circuits. It may be deliberate and desired (as in an antenna coupler) or may be undesired (as in power line inductive coupling into telephone lines). Inductive coupling can be an important reason for interference due to transients. HF voltage or currents in

the high voltage side, >230V, which couple into electronic circuits where the voltage is 5-25V can easily cause malfunction or damage the circuit. One percent coupling can easily change a binary zero into a one, and ten percent coupling can destroy the integrated circuit. Fast current transients with high di/dt cause inductive coupling. There are some methods to minimize inductive coupling:

- Minimize loop areas of signal and return paths.
- Move different loops farther apart from each other.
- Increase rise and fall times.

### 1.5 Classification of transients

Transients occurring in a power system can be divided into two main categories:

1. Non-oscillatory transients.
2. Short-time oscillating transients.

The transients can either be positive or negative, with a rise time of microseconds to milliseconds and with a time limit up to a maximum at 10 ms. Damped oscillation transients, of both positive and negative polarity, can have longer durations [1]. Transients can also be classified in the terms of energy content although this is not the case in the existing standards. The IEEE standard 1159:1995 gives the following classification for oscillatory transients and impulsive transients:

Categories	Typical spectral content	Typical duration	Typical voltage magnitude
<i>Impulsive transients:</i>			
Nanosecond	5 ns rise	<50 ns	
Microsecond	1 $\mu$ s rise	50 ns- 1 ms	
Millisecond	0.1 ms rise	>1 ms	
<i>Oscillatory transients:</i>			
Low frequency	<5 kHz	0.3-50 ms	0-4 p.u.
Medium frequency	5-500 kHz	20 $\mu$ s	0-8 p.u.
High frequency	0.5-5 MHz	5 $\mu$ s	0-4 p.u.

**Table 1.1 Characteristics for power system voltage transients according to IEEE 1159:1995.**

Low voltage transients are generally below 6 kV according to the European standard EN 50160, and linked to the setting of the overvoltage protection in low voltage systems. The highest overvoltage which does not trip the

overvoltage protection should not cause any damage to end-user equipment, but of concern is also incorrect operation of the equipment. This is true only for newer systems; in many of the older systems this protection does not exist [24].

For transients in low voltage networks the following values are typical [1]:

Type and/or duration	Amplitude	Mode
Transient duration in ms range	$\leq 400$ V	DM
Transient duration in the $\mu$ s range	$\leq 6$ kV	DM
Oscillating transients 30 kHz-2 MHz	$\leq 6$ kV	DM
Very fast transients in the ns range	$\leq 4$ kV	CM

**Table 1.2 Typical values for low voltage networks where DM (differential mode) is the cross voltage between conductors and CM (common mode) are the voltages between all conductors and earth.**

The limits in the standards only mention the voltage transients. For current transients there are no such limits. The voltage limits for the transients are not guaranteed to be harmless but are values existing in normal operation. Some grid owners, for example Göteborg Energi, have their own recommendations for power quality phenomena and for transient events. Göteborg Energi states “the level of transients occurring regularly and disturbing the customers shall be held at the lowest amplitude and number possible”.

There are also some other parameters that can be used when classifying transients in power systems and they are:

- Transient harmonics.
- Decay time constant.
- Occurrence frequency.

In the EMC standard IEC 61000-2-5 conducted oscillatory and unidirectional voltage transients are treated.

### 1.5.1 Magnitude, duration and energy of transients

It is important to be aware of the different definitions for magnitude and duration for transients. The magnitude of a transient can be defined as either maximum voltage or maximum voltage deviation. The duration can be defined as the voltage recovered to within 10% of the magnitude of the transient overvoltage or the time constant of the average of the voltage decay, or the ratio of the Vt-integral and the magnitude of the transient overvoltage. The energy content in the transient is defined by the following, where T is the time when the amplitude of the transient has decreased to 10% of its maximum value:

$$\int_0^T V(t)^2 dt$$

**Equation 1.6 Energy content for voltage transient.**

The same definitions can be applied for current transients.

## 1.6 Effects on equipment

A literature survey has been performed to find out different cases of damage and mal-operation of equipment due to transient disturbances.

### 1.6.1 Capacitor switching problems

Examples of mal-operation due to capacitor bank switching are well documented in literature [9,10,11,12,13,14]. The main problems mentioned in the literature are:

- Adjustable-speed drives trip on overvoltage.
- Tripping of other loads with electronic power supplies.
- Damage of the transistors due to overvoltages, which are of relatively low magnitude but of long duration.
- Damage of overvoltage spark gaps and varistors due to long-duration overvoltage.

The transient due to capacitor bank switching has frequencies of several 100 Hz, with normal amplitudes up to 1.5 p.u. Due to voltage magnification, capacitors at lower voltage levels with similar resonance frequencies may show overvoltages which are much higher [10]. Measurements performed at different voltage levels [15] show overvoltages of 1.4 p.u. at 36 kV, 1.5 p.u. at 13.2 kV, 2.3 p.u. at 4.16 kV and 3.2 p.u. at 480 V.

Damage to the diode front-end of an adjustable speed-drive due to the large current through the diodes when the overvoltage appears at the equipment terminals, is mentioned in [16]. Insulation failures in harmonic filter banks are mentioned in reference [17].

Synchronized switching will alleviate problems, but not prevent all of them. As shown in reference [18], the requirements on the accuracy of the synchronized switch are higher than possible with existing techniques. Drives will trip when the instantaneous supply voltage exceeds 1.3 p.u. Due to voltage magnification this value will be significantly exceeded, even with synchronized switching.

### 1.6.2 Other transients

Voltage notches due to adjustable-speed drives with a thyristor front-end are treated in [19]. These notches can lead to a high incidence of thyristor fuse blowing and drive component failures. Other sensitive equipment can exhibit power quality problems. According to [19] problems not only occur near the drive causing the notches, but also elsewhere in the power system.

Reference [20] summarises problems due to voltage transients at a number of sites. The study involved a total of 23 sites in rural Canada. The following problems were reported at more than one site:

- Switch failure.
- Operational problems with electronic controllers.
- Damaged TV, VCR or satellite dish.
- Power equipment burn up.
- Computer monitor or printer damaged beyond repair.

In reference [21] is a case described where compact fluorescent lamps malfunctioned due to high-frequency harmonics in the supply voltage.

Problems due to harmonics and voltage level notching on electronic equipment are discussed in [22]. The notch, when propagated into the system, leads to high-frequency oscillation, which in turn can disrupt equipment.

The IEEE Emerald Book [23] gives the following list of effects of transient overvoltages on end-user equipment:

- Electrical insulation breakdown or sparkover.
- Surge protection device failure.
- Semiconductor device failure.
- Power conversion equipment nuisance trip.
- Data-processing equipment malfunction.
- Light bulbs fail prematurely.

For several of these effects, the rate of rise of the voltage, and the frequency in case of oscillation, is as much of a concern as the peak amplitude.

Fast transient overvoltages are generated by restrikes of a disconnecter in a gas-insulated switchgear. These transients may cause a high frequency oscillation in the transformer wiring and overstress the winding insulation [5].

Data communication systems that use electrical interconnections between remote nodes are sensitive to transients that can upset the operation of the system. This can result in a bit error rate or even permanent damage to the equipment [6].

### 1.6.3 Investigations and economical consequences

Most of the transients in a building are originating within the building. The customers are generating about 60% of the voltage transients [8]. A survey from the Swedish company FOA shows a large difference in number of transients for different industries in the same area [31].

The investigation of the Swedish industry performed in this project and evaluated in chapter 4, show that there are problems with transient disturbances in the industry.

During this project laboratory measurements with fast on/off switching of computers were performed, and during these tests one computer screen



suddenly ceased to work. This was probably due to the many switching actions performed in the tests. The rather modest voltages generated in switching actions generate very high transient overcurrents. Although these current transients are very short in duration, they may harm equipment in the long run. Switching operations and lightning discharges cause the overvoltage damages in figure 1.5. A study from Germany made in 1997 [4] shows that switching operations and lightning discharges is the cause of about 32% of the damage in the electronics sector. These damages include large industries as well as power supply lines and home buildings. The report is based on more than 9600 cases. The survey is made by a German electronic insurance company. The total cost of damage caused by transients in 1997 was estimated to one billion DM. Surge damages analysis show that lightning discharges are the dominant disturbances followed by those due to switching operations in power systems.

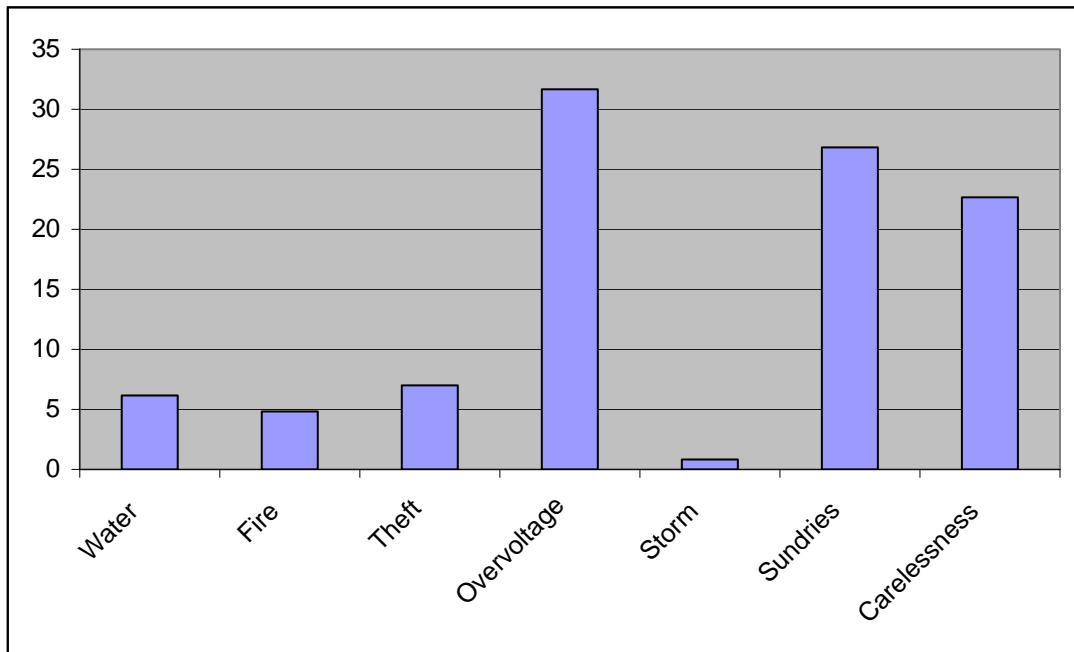


Figure 1.11 Electronics sector, damage in 1997, analysis of more than 9600 cases of damage [4].

### 1.7 Aim of the project

The aim of this project was to achieve a better understanding of transients and their behaviour by measuring and simulating switching transients in well-defined systems, both in a laboratory network and an office network. Measurements have been performed using Dranetz monitors and the simulations have been done in the PSpice simulation program.

Another task was to find out how Swedish industrial companies are affected by transient disturbances. A questionnaire concerning disturbances was sent out to approximately 100 Swedish industrial companies. Replies were obtained from 30 companies. Investigation of transient load behaviour was also included in the project.

Although many measurements in this area have been performed earlier, few projects have been focusing on simulating the measurements and thereby reaching a greater understanding of transient behaviour and the complexity of load behaviour.

Protective devices against transient disturbances are not discussed in this thesis.

## **1.8 Contents of the thesis**

### *Chapter 2*

In this chapter both the measurements and the simulations are presented. The measurements and the simulations are presented in the same chapter for easier comparison between them. Further details about the measurement and the simulation system are found in appendix A, B and D.

### *Chapter 3*

In this chapter some other measurements are presented. These measurements were taken both in laboratory environment and in live networks.

### *Chapter 4*

In this chapter the evaluation of the questionnaire is presented. The questionnaire was sent out to approximately 100 Swedish industrial companies to find out what the problems are with transients in industrial networks. The entire questionnaire is presented in Appendix C.

### *Chapter 5*

In this chapter conclusions and future work are discussed.

## 2 Measurements and simulations

### 2.1 Background

The objective of the measurements and the simulations was to analyse the switching transients in low voltage systems. The purpose of the measurements was also to determine the transient behaviour of low voltage loads. With correct modelling it is possible to characterize different types of transients and the origin of the transients.

#### 2.1.1 Measurements

The measurements have been performed using both a strong power system (laboratory network) and a weak system (office network). The loads were computers and computer monitors. The main measurement system was a Dranetz 658 Power Quality Monitor. The focus was on the transients caused by energizing the computers, as the de-energizing actions did not cause any transients. In the first measurement series one computer was energized. In the second measurement series one computer was energized and few seconds later a second computer. In the latter case the transient from the second computer was studied. One of the computers had a soft starting system and therefore the transients from this computer were only detectable in a few measurements. More details about the measurement system and its specifications are given in Appendix A.

#### 2.1.2 Simulations

The simulations were performed using the PSpice simulation program. The simulated circuit was a switched-mode power supply used in computers. The load behind the power supply is not represented in the simulation circuit, as the time range studied is only some tenths of milliseconds. The values of the system components were estimated from the specifications for the laboratory and the office system respectively. These calculations are given in Appendix B. After examining the power supply in the computer a simplified circuit was used in the simulations. Details about the simulation program can be found in Appendix D.

## 2.2 Voltage measurements and simulations with one computer

### 2.2.1 The laboratory supply network (strong system)

The strong system is the laboratory supply network where load is present during laboratory experiments; otherwise little load is present. As the propagation of switching transients is limited to short distance [33], the load absorbing energy has to be located very close to where the switching action is, if damping of the transient will occur. The measurements have shown that load has to be present on the same feeder in order to influence the transient behaviour. Load present in the network affects the oscillating frequency. In the measurements performed the energizing action generates detectable transients

while de-energizing actions are undetectable. De-energizing action is always taking place at zero current crossing and do not generate any noticeable transients in case of resistive loads.

### 2.2.1.1 Measurements

Figure 2.1 shows the scheme of the power network and the first part of the power supply for the computer. A simplified circuit is used in the simulations. Some of the small capacitors with values of some nanofarads are oscillating with the inductances in the circuit at a very high frequency and do not affect the frequency range of interest.

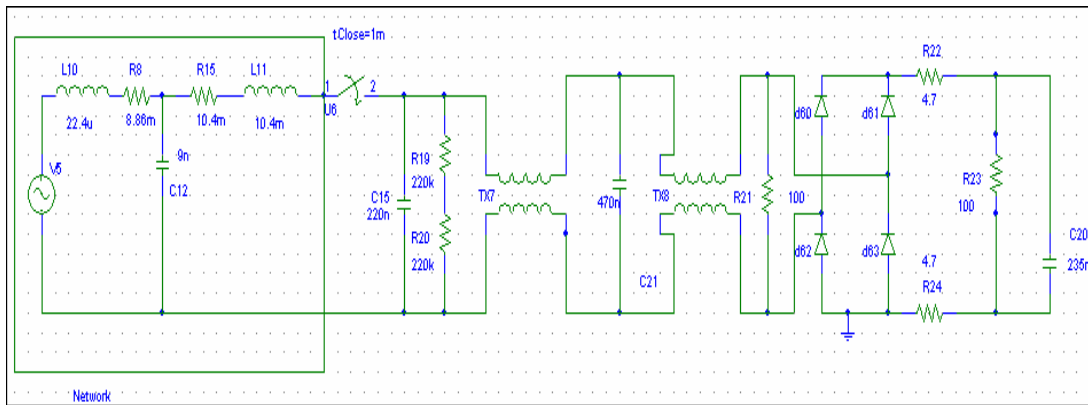
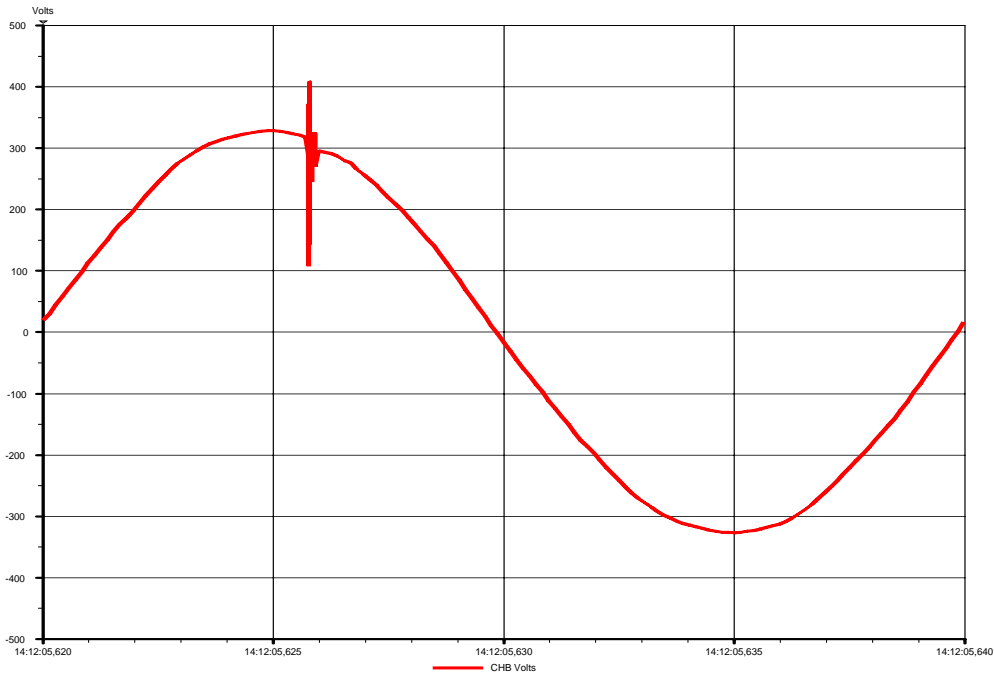
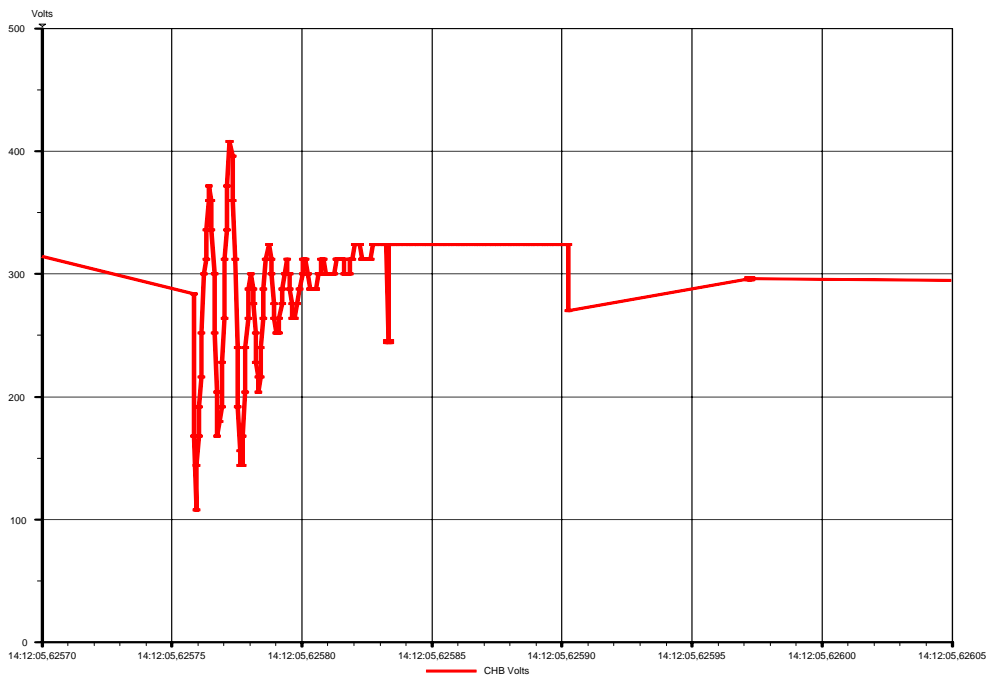


Figure 2.1 Computer power supply.

Figure 2.2 shows a voltage transient caused by a computer energizing action. Figure 2.3 shows the same transient enlarged. The voltage across the capacitor (C15) is zero before switching, and therefore the voltage immediately after the performed switching action is also zero. As a result the first part of the transient is directed towards voltage zero. The transients observed are typical for the tested equipment.



**Figure 2.2 Voltage transient due to computer switching, one computer, measurement.**



**Figure 2.3 Voltage transient due to computer switching, one computer, measurement, enlarged.**

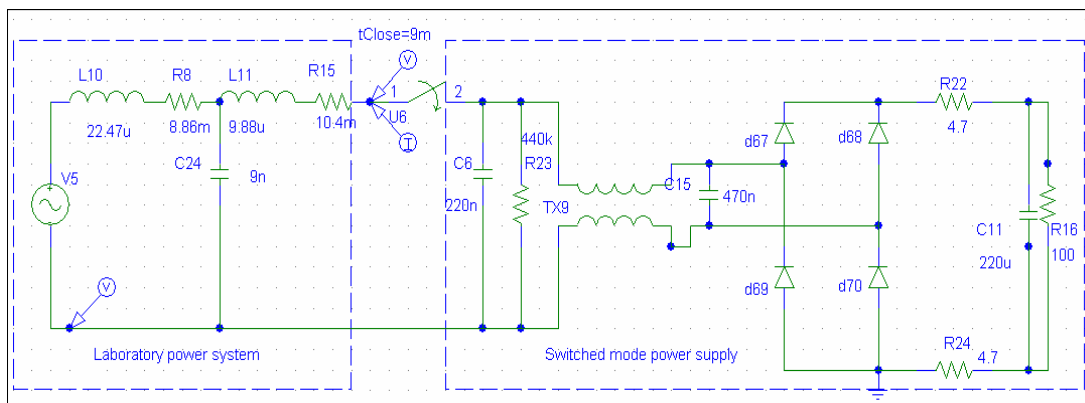
The minimum value in the oscillation is 110 V, and the maximum value is 410 V. The oscillation frequency in this case is approximately 110 kHz. The maximum oscillation amplitude (peak to peak) is 300 V. The increase in amplitude in the second and the fourth oscillation is probably due to the presence of oscillations with different frequencies. The results in the

simulations show the same behaviour. Due to the limited sampling frequency it is not possible to do a correct frequency analysis of the measurements.

The measurements show that computer switching in a system may result in transients with high amplitudes. The energizing of several computers simultaneously can result in very high amplitudes. At one occasion, when the power was returning after a black out at an office at Chalmers University of Technology, the low-voltage circuit breaker tripped due to the combined inrush currents of all computers. The reason for this was that almost all computers were in stand by mode before the black out. The computers had to be switched off and then turned on in batches to avoid a new tripping.

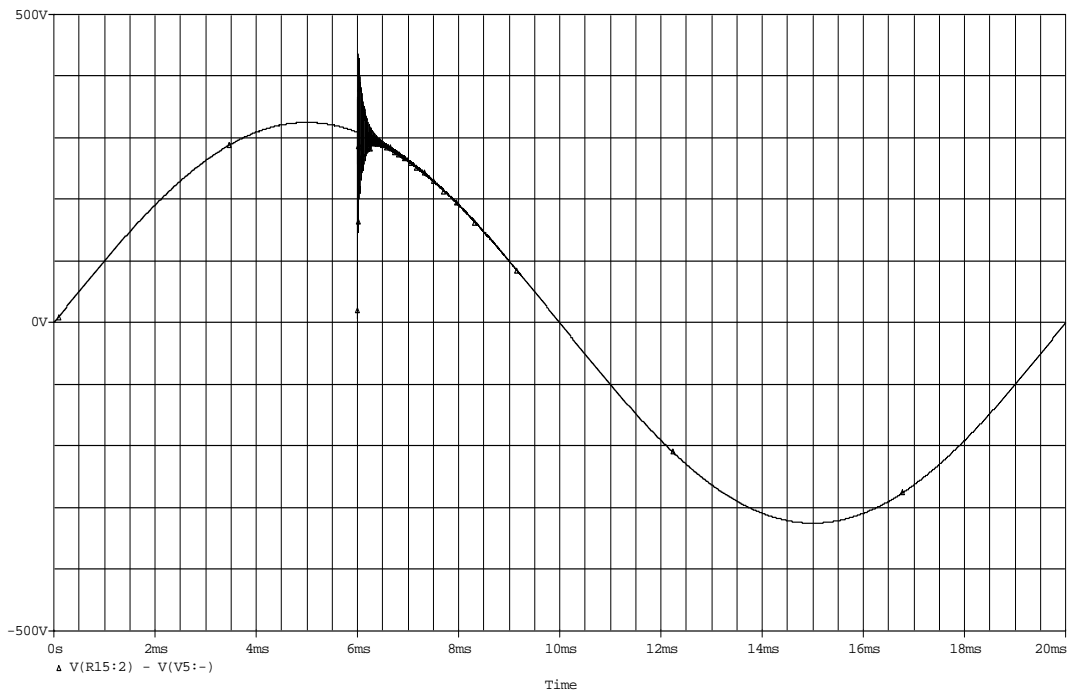
### 2.2.1.2 Simulations

The simulation circuit for one computer is shown in fig 2.4. The simulation circuit is the first part of a typical switched-mode power supply. The interest in the simulations was the initial transient behaviour. The first part of the circuit is the circuit representing the transformer and the cables of the network supply, (Laboratory power), (Laboratory power). The second part, Switched mode power, are the computer components.

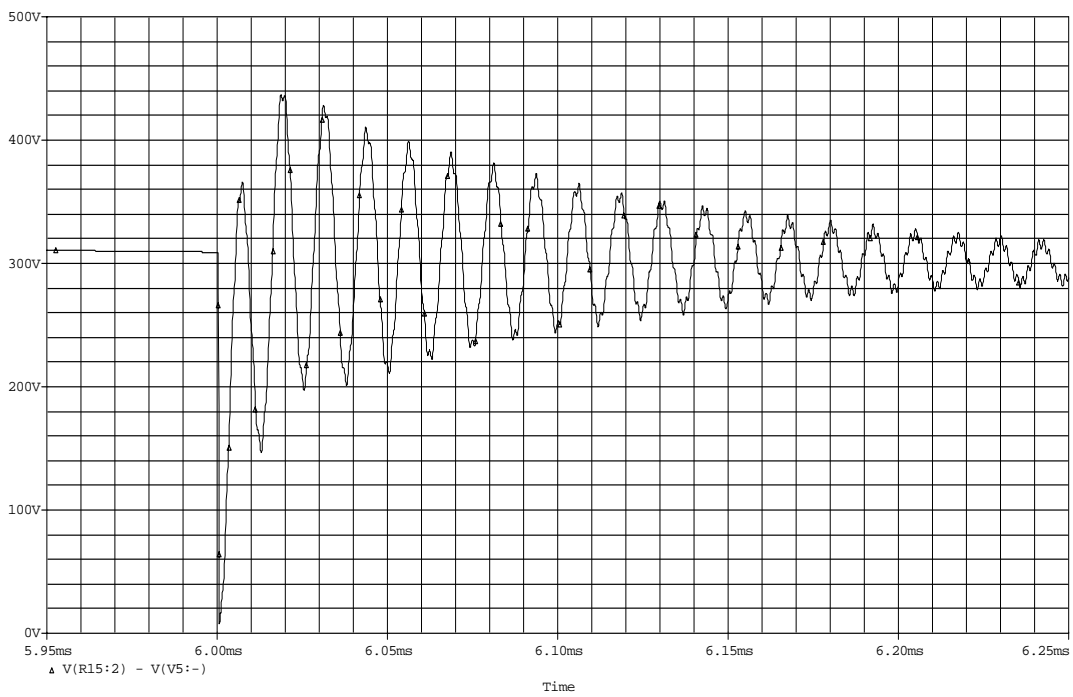


**Figure 2.4 Simulation circuit for one computer, laboratory supply network.**

Simulating the circuit gives the following results. The minimum value is 10 V and the maximum value is 430 V. The oscillation frequency is 80 kHz. See figure 2.5 and 2.6. The maximum oscillation amplitude (peak to peak) is 420 V. These values are derived from the plotted curve.



**Figure 2.5 Voltage transient due to computer switching, one computer, simulation.**



**Figure 2.6 Voltage transient due to computer switching, one computer, simulation, enlarged.**

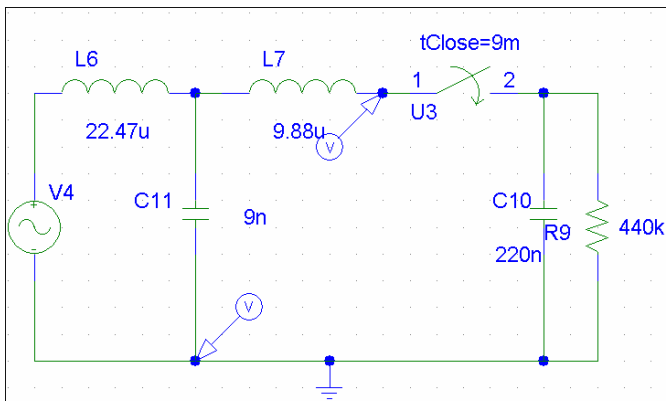
The oscillation frequency is mainly the frequency between the source impedance ( $L10+L11$ ) and the circuit capacitor plus the source capacitor ( $C6+C24$ ):

$$f = \frac{1}{2\pi\sqrt{LC}}$$

**Equation 2.1 Resonance frequency for the simulation circuit.**

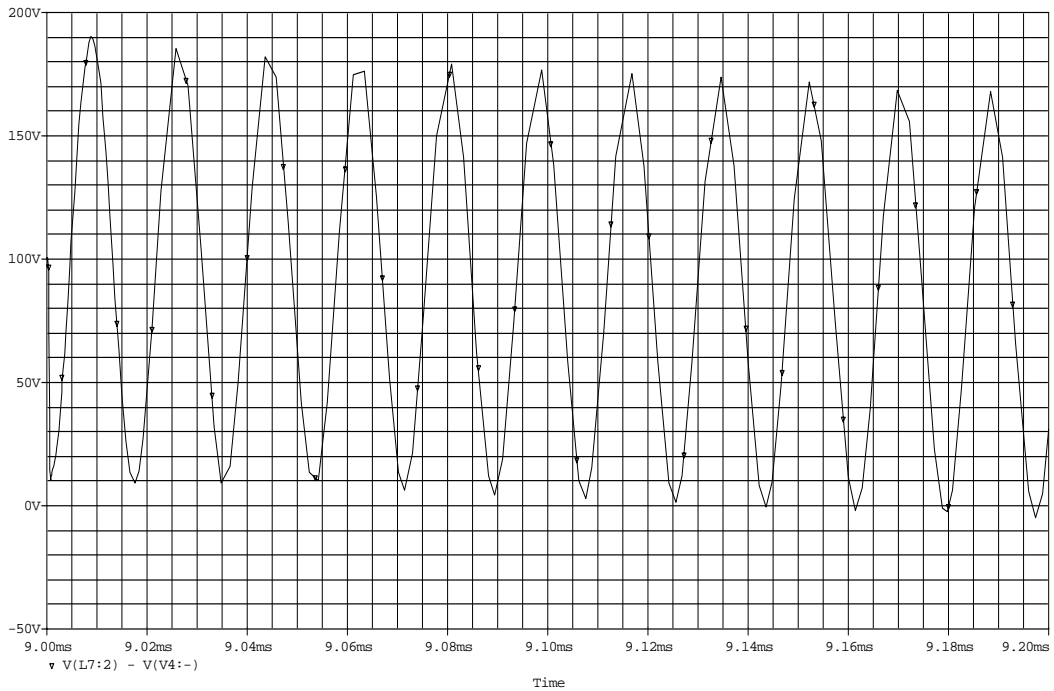
The calculated frequency from equation 2.1 for the laboratory supply network is 58.5 kHz compared to the simulated frequency derived from the plot which is 80 kHz. The difference in the frequency between the calculated value from equation 2.1 and the estimated value from figure 2.6 indicates influence from other components in the circuit. A simulation with a circuit shown in figure 2.7, where only the first capacitor in the switched mode power supply is present, results in a frequency derived from the resulting plot of 60 kHz. See figure 2.8. This is well corresponding to the calculated results from equation 2.1.

This indicates that equation 2.1 is not fully explaining the frequency behaviour of the circuit. The other components in the switched mode power supply are also affecting the frequency behaviour. The simulation indicates that the frequency is increasing when the whole circuit is present.



**Figure 2.7 Simulation test schematics.**





**Figure 2.8** Frequency plot from simulation test circuit.

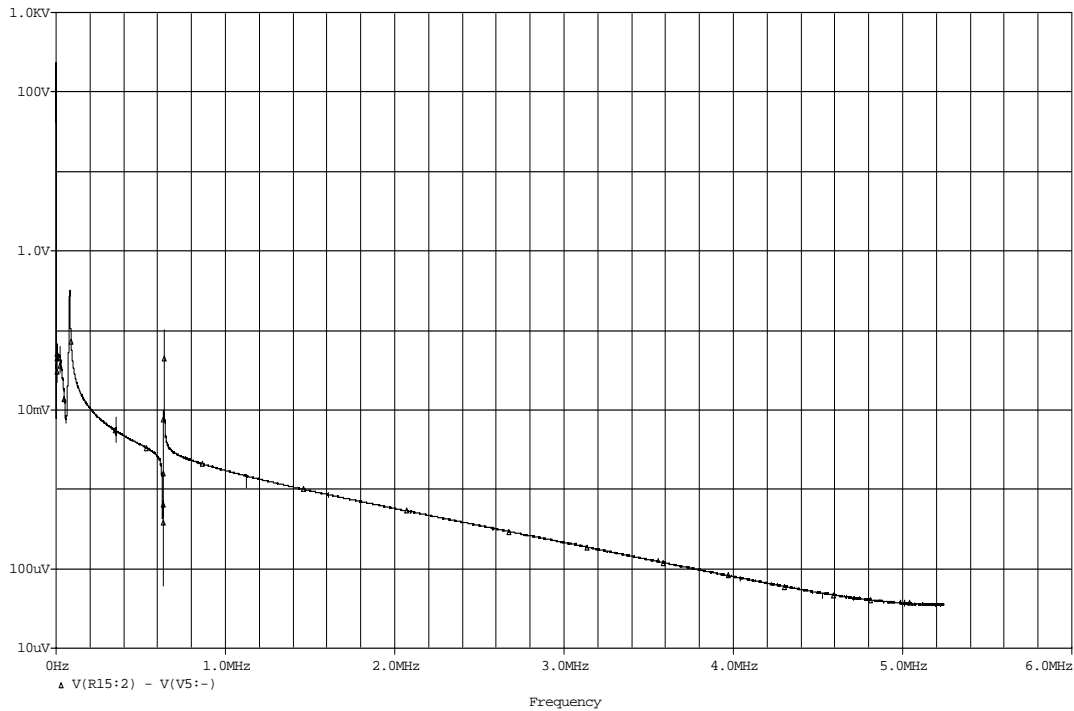
The damping time constant in the offset voltage step is depending on the inductance in the filter (TX9) and in the resistance (R16) in figure 2.4:

$$\tau = \frac{L}{R}$$

**Equation 2.2** Time constant in the oscillation

The inductance in TX9 is 22 mH while the resistance in R16 is 100 ohm. This results in a  $\tau=0,22$  ms which is well corresponding to the simulation in fig. 2.6. This is the time-constant of the decay of the voltage transient and one of the possible ways to characterize transients in power systems.

The simulations show more than one oscillating frequency. A frequency analysis FFT, made on the simulation result in figure 2.6 is shown in figure 2.9. This indicates several frequencies in the resulting oscillation. There is one frequency just below 100 kHz, which is well corresponding with the results from the derived curve in figure 2.6. Further frequency analysis is not performed here.



**Figure 2.9** Frequency analysis of the simulation.

### 2.2.1.3 Comparison between measurements and simulations

The difference between the measurements and the simulations is a factor 1.4. The frequency derived from the simulation results 80 kHz and the results from the measurements is 110 kHz. In the simulations it is assumed that the network is unloaded. If load is present in the network the inductance oscillating with the capacitance in the computer may be lower than the values in the simulated circuit.

A load is present in the simulation circuit in figure 2.10. When simulating this circuit and deriving results from the plotted curve in figure 2.11 an oscillation frequency of about 110 kHz is achieved. This indicates that a certain amount of load present before the tested load increases the oscillation frequency. The load characteristics obviously have influence on the oscillation frequency and the oscillation characteristics. It also explains that the oscillation frequency not always is the same in the performed measurement, as the load is different at different occasions.

The maximum oscillation amplitude is 320 V for the simulated circuit compared to 250 V for the measurement. The resistances in the computer are damping the transient in the measurement. The simulated transient oscillates at a lower voltage level than the measured transient. This is due to a voltage drop at the first moment of the switching action. The difference in offset voltage can be explained by different resistance values in the circuits.

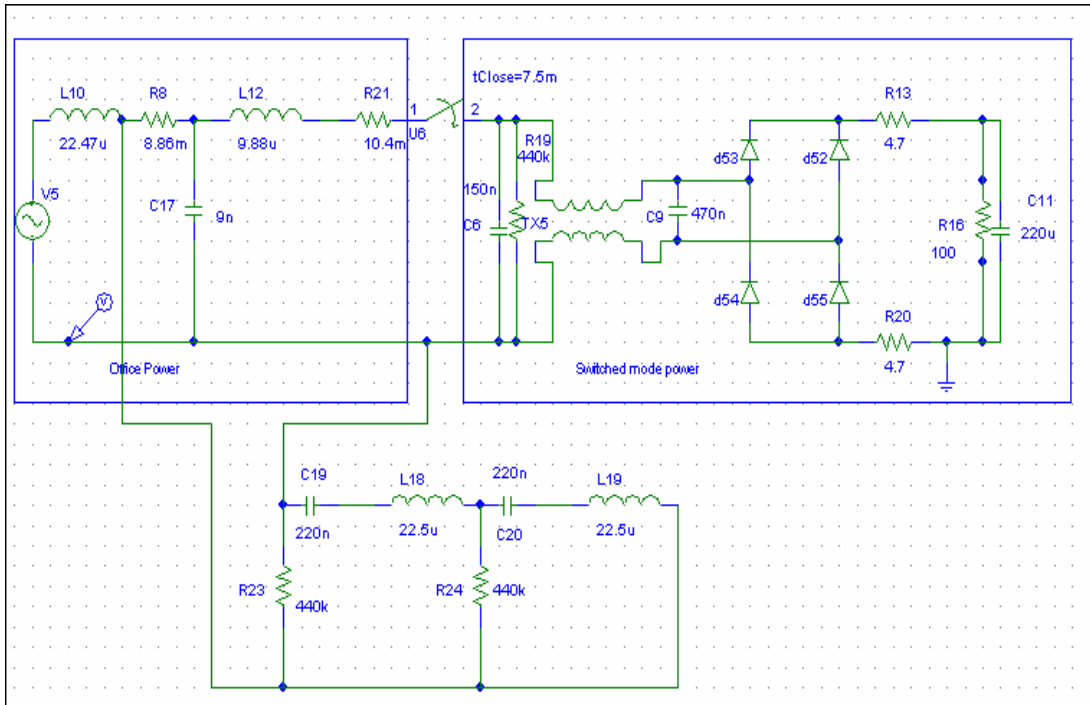


Figure 2.10 Switched power supply with load present before computer.

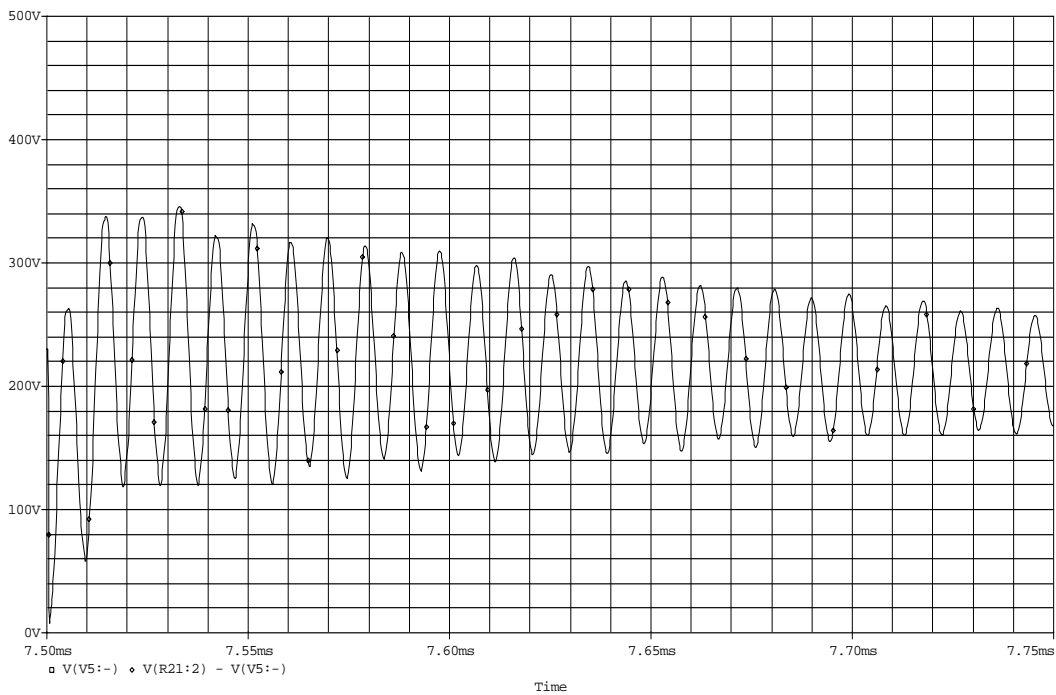


Figure 2.11 Oscillation for the loaded network

The duration for the measured and the simulated transients are in the same time range. The results show that it is possible to simulate voltage transient behaviour from one computer. These results can be used for explaining transient behaviour from equipment if the network parameters, the inductance and the capacitance in the switched mode power supply are known. The result

can also be used for detecting the transient producing equipment in a network if the parameters in the network and in the load are known. It is also important to locate other load in the network as the oscillating frequency is affected depending on type of load. Serial resistance in cables will increase the rise time and decrease the peak amplitude of the transients. As a real network is more complicated than this it is also of great importance to investigate the behaviour for other networks and switching more than one load.

### 2.2.2 Weak system, office supply network

The parameters differing from the laboratory supply network are the inductances for the transformer and cables, the cable capacitance and resistance. The values are shown in the simulation circuit, figure 2.14.

#### 2.2.2.1 Measurements

Figure 2.12 shows a voltage transient caused by computer switching action. The transient is similar to the one generated in the other network. Figure 2.13 shows the same transient enlarged.

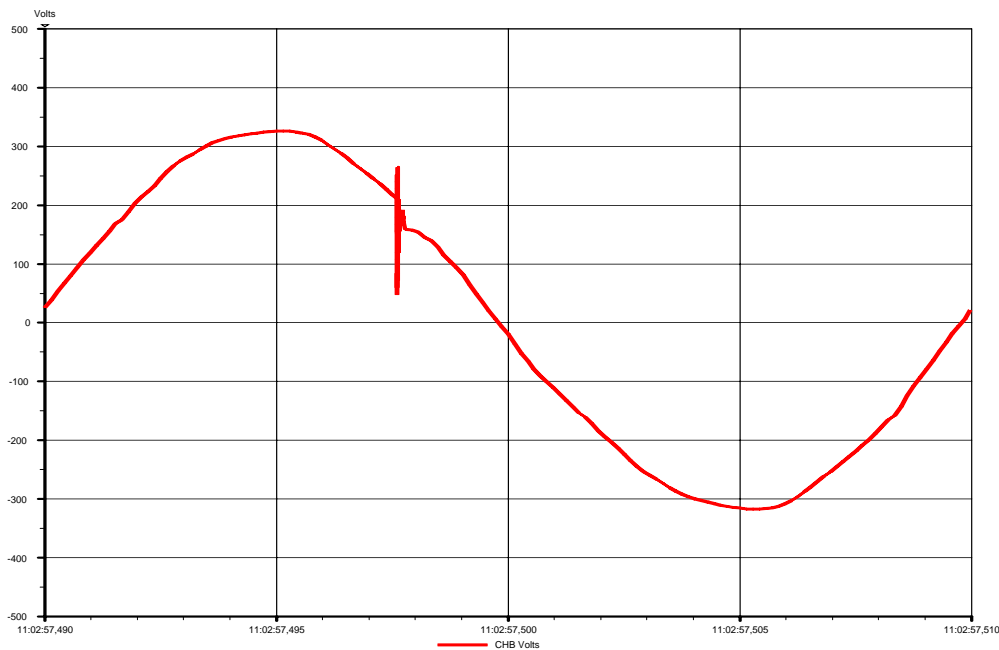
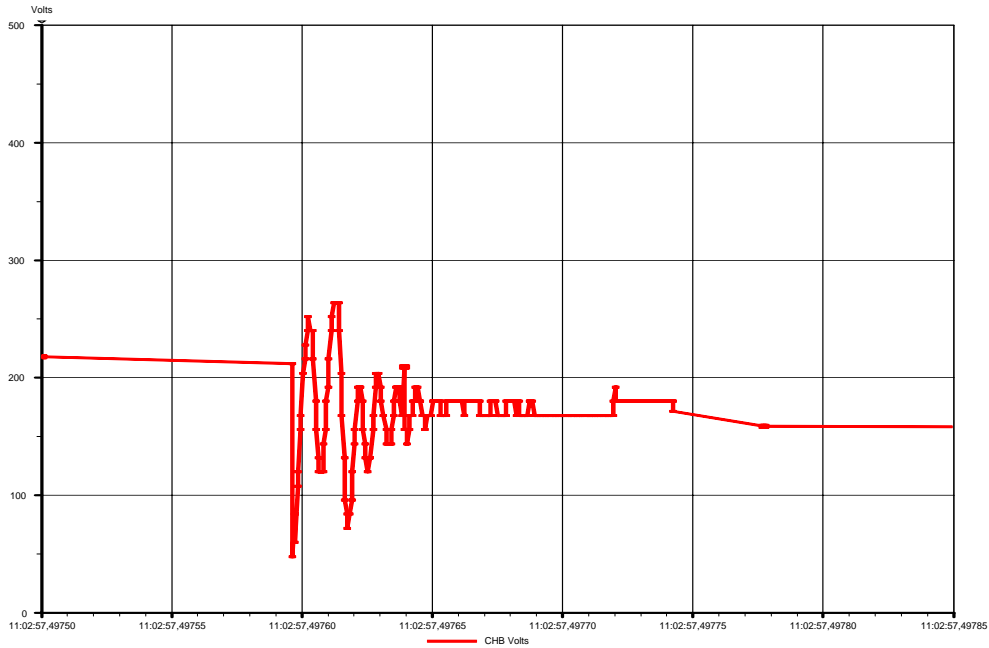


Figure 2.12 Voltage transient due to computer switching, one computer, measurement

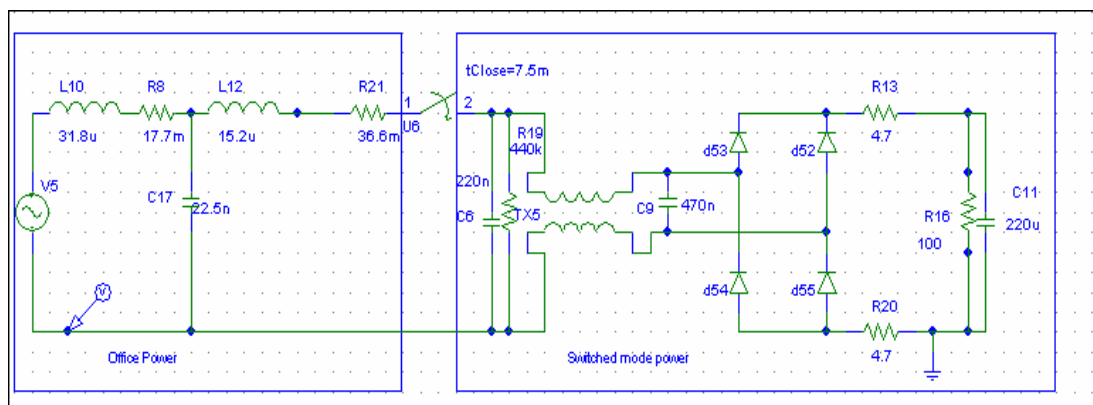


**Figure 2.13 Voltage transient due to computer switching, one computer, measurement, enlarged**

The minimum value in the oscillation is 50 V, and the maximum value is 250 V. The oscillation frequency in this case is 100 kHz. The maximum oscillation amplitude (peak to peak) is 200 V. All these values are derived from the measurement results. The oscillation frequency for the office supply network is lower than in the laboratory supply network due to the larger source inductance. The maximum oscillation amplitude is in the same range as the measurement in the other network. The closer the switching action is to a zero crossing the smaller the transient amplitude is.

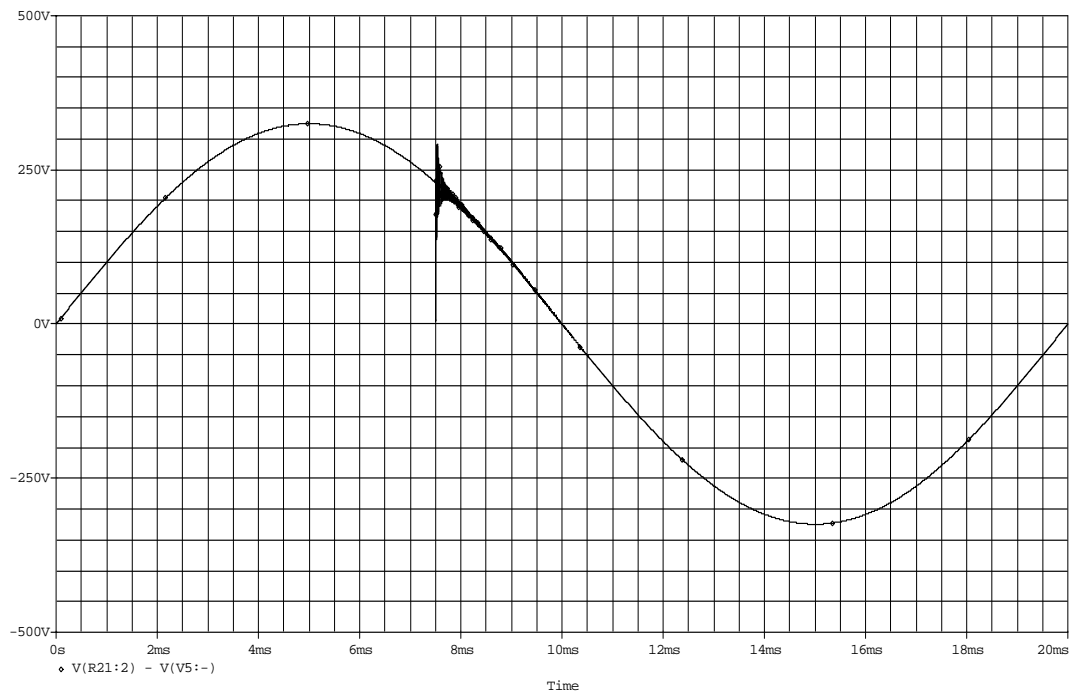
### 2.2.2.2 Simulations

The simulation circuit for one computer is shown in figure 2.14.

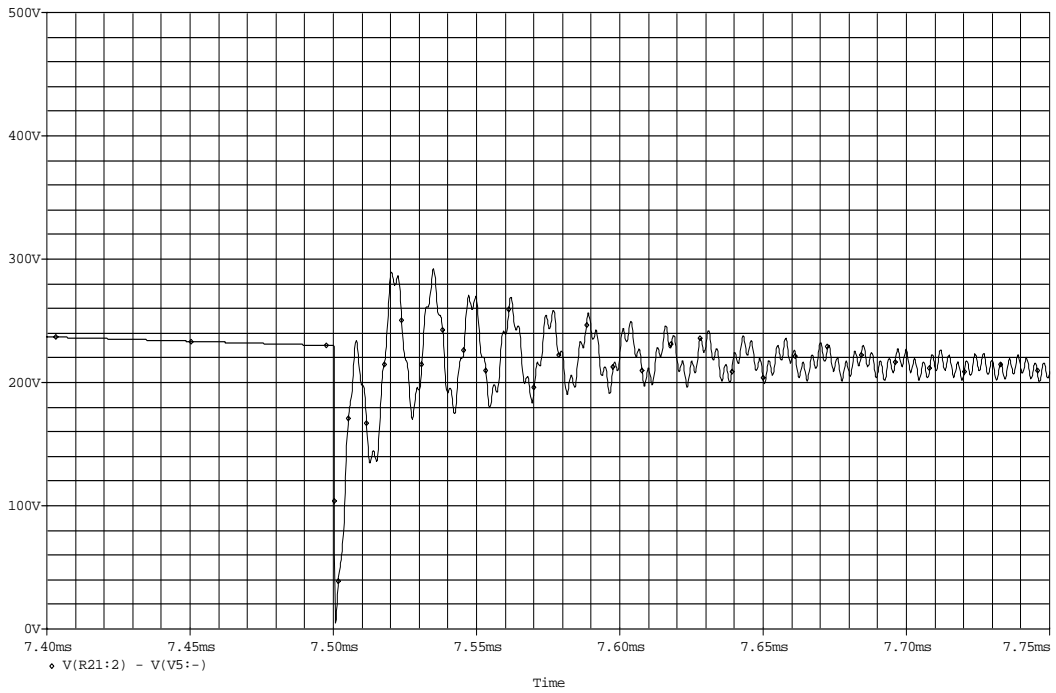


**Figure 2.14 Simulation circuit for one computer, office supply network.**

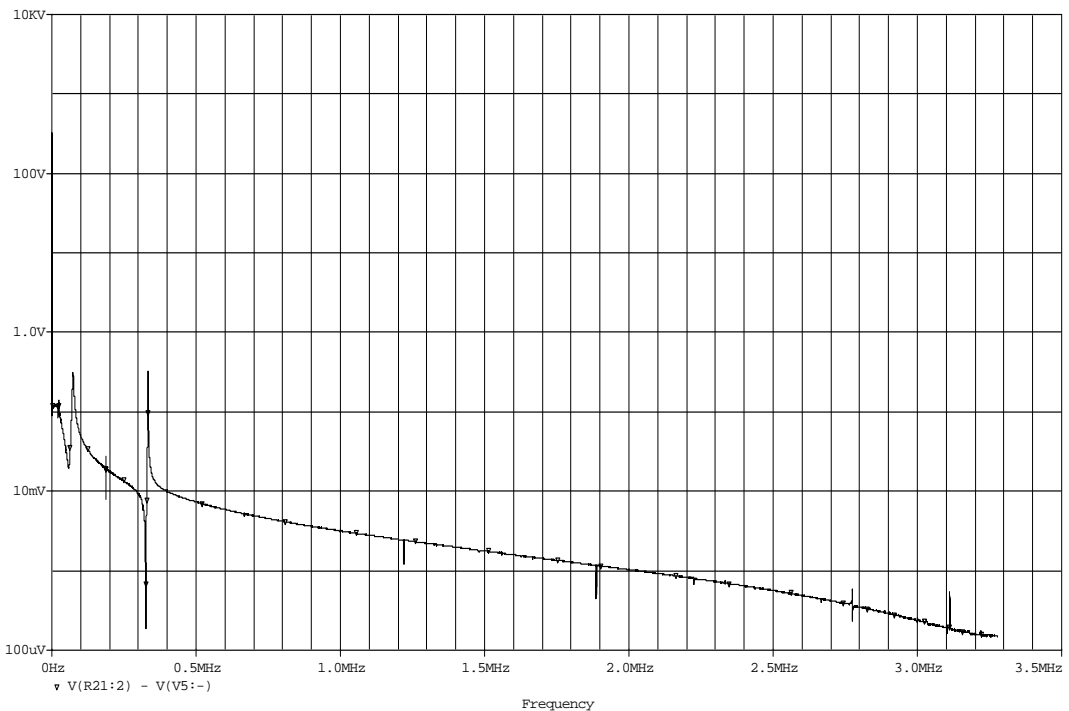
Simulations from the office supply network are shown in figure 2.15 and 2.16. The minimum value is 5 V and the maximum value is 270 V. The oscillation frequency is about 70 kHz derived from the simulation results. There are several oscillation frequencies present in the simulation. The calculated frequency from equation 2.1 is 47.1 KHz. The maximum oscillation amplitude (peak to peak) is 265 V. The time constant is calculated from equation 2.2 and the values of these components are not differing from the laboratory supply network. The result,  $\tau=0,22$  ms, is rather well corresponding to the curve in figure 2.16. A frequency analysis of the simulation is shown in figure 2.17.



**Figure 2.15 Voltage transient due to computer switching, one computer, simulation.**



**Figure 2.16** Voltage transient due to computer switching, one computer, measurement, enlarged.



**Figure 2.17** Frequency analysis of the simulation.

### 2.2.2.3 Comparisons between measurements and simulations

In this case the difference between the measurements and the simulations is a factor 1.4. The frequency derived from the simulation results 70 kHz and the results from the measurements is 100 kHz. The difference is in the same range

as in the previous case where the laboratory supply network is used. The difference indicates that the existing load, a lot of computers, in the office supply network has influence on the frequency characteristics but not on the amplitude and duration the transients. In the simulations there are more visible frequencies than in the measurements. This is due to the limited sampling frequency of the measurement equipment. The load in the office network is not located at the same feeder as the measured transients. The expected damping of the transient in the office supply network due to this existing load is undetectable. Resistance in the network is absorbing energy from the transient and therefore damping the oscillation. In this case it is obvious that the existing resistance is located too far away from the switching action to have influence on the behaviour. Compare with the measurements on two computes located at the same feeder in section 2.3.

### 2.3 Voltage measurements and simulations of two computers

The transient voltage measurements and simulations for two computers are performed in the office supply network.

#### 2.3.1 Office supply network

##### 2.3.1.1 Measurements

The transient of the second computer switching is shown in figures 2.18 and 2.19.

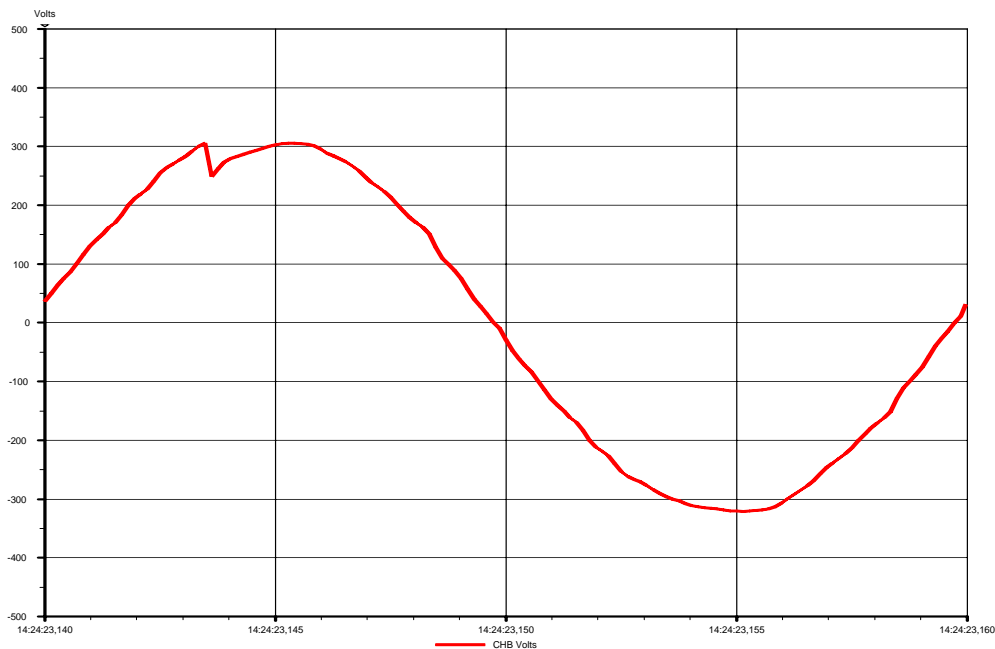
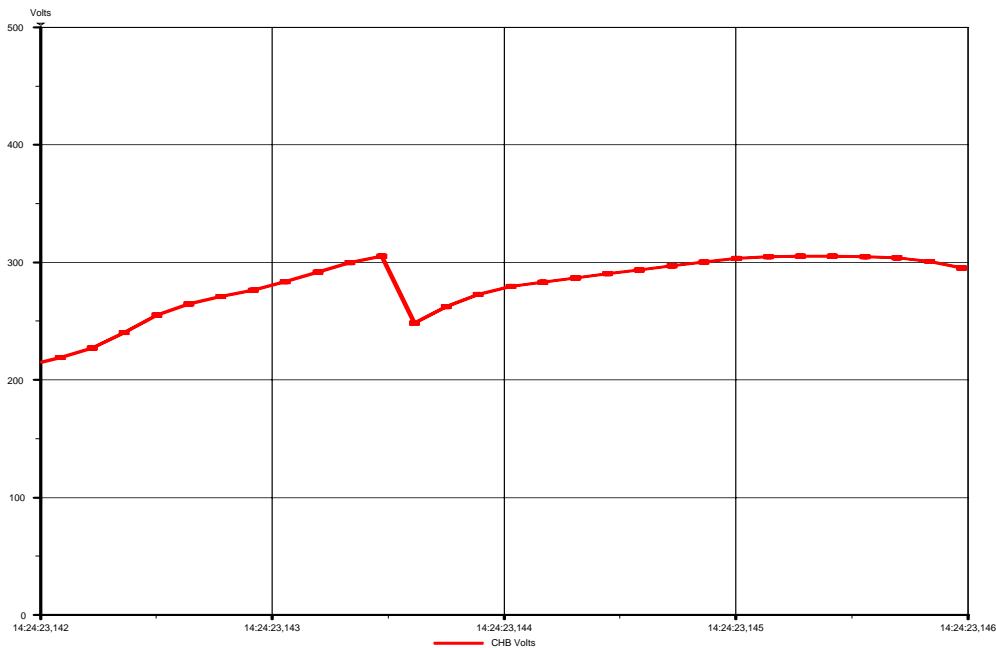


Figure 2.18 Voltage transient for second computer switching action, measurement



If the first computer is switched on the transient is similar to the transient in the one-computer measurement. The characteristics for the second transient are depending on the load already existing on the same feeder. The existing load absorbs the main part of the transient energy. The amplitude is lower and there is no high frequency oscillation visible in the measurement. The HF oscillation is probably present but the frequency is not detectable for the measuring equipment. Compare with the simulations. The voltage drop is 50 V. The voltage dip in the transient is probably due to the large inrush current that occurs when the computer is energized. This shows that load has to be present electrically close to the switching transient to have any influence in the characteristics.



**Figure 2.19** Voltage transient for second computer switching action, enlarged.

### 2.3.1.2 Simulations

The second computer is installed on the same feeder. An inductance (L11) is representing the distance between the computers. The simulation circuit is shown in figure 2.20.

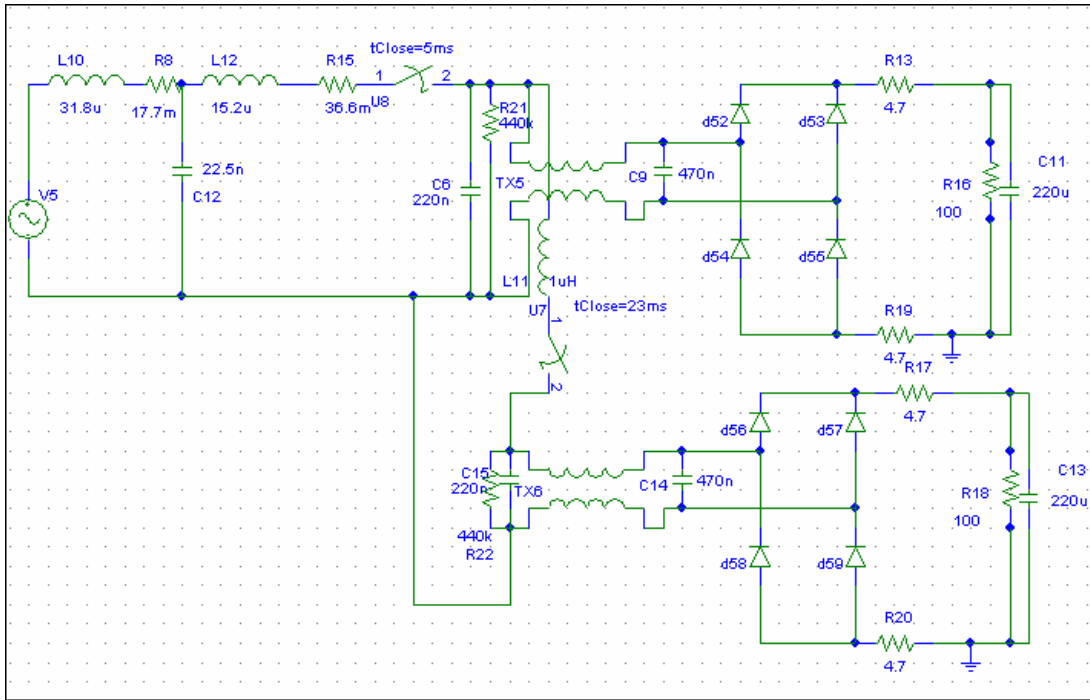


Figure 2.20 Simulation circuit for two computers.

The results from the simulations are shown in figure 2.21 and 2.22.

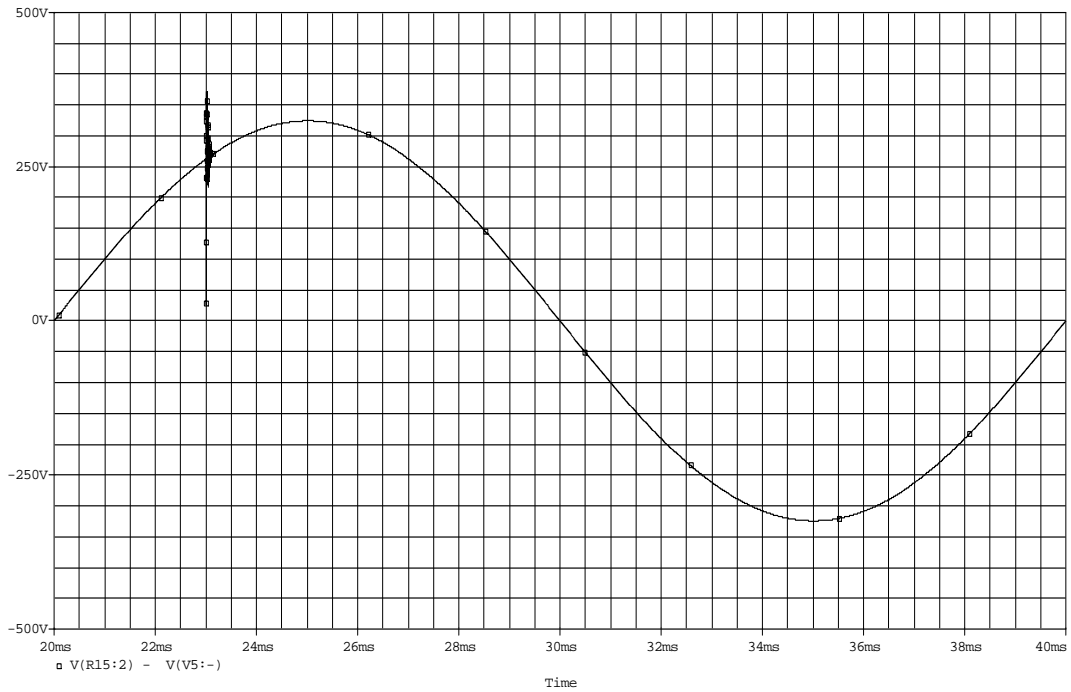
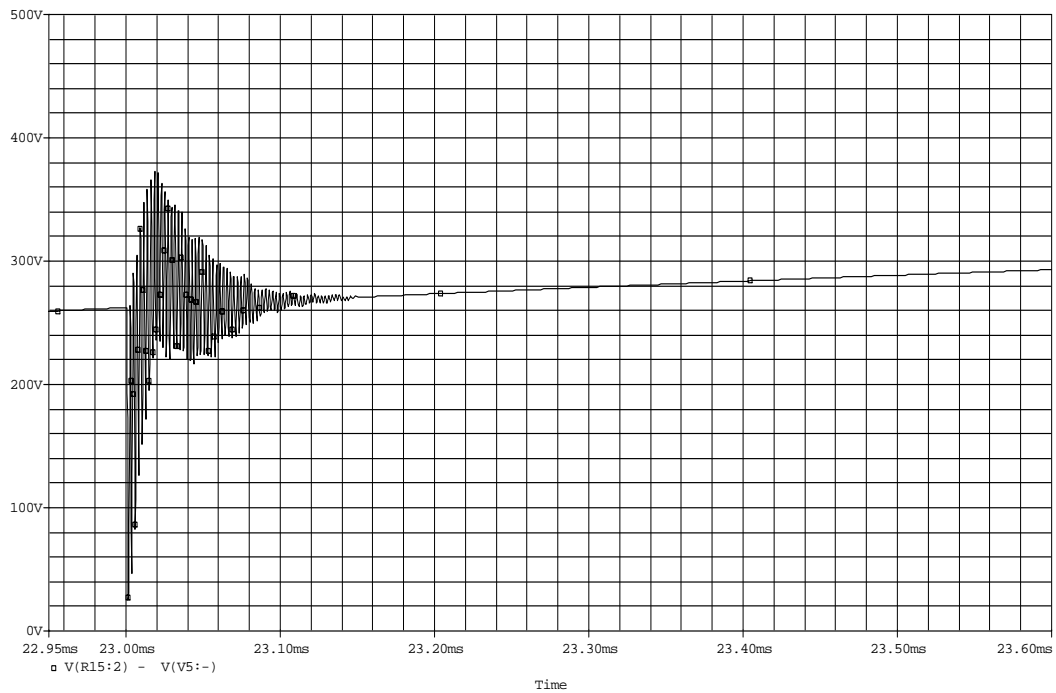


Figure 2.21 Voltage transient for second computer switching action, simulation



**Figure 2.22 Voltage transient for second computer switching action, enlarged**

The transient in the simulation has high amplitude. The simulation circuit is the primary side of the switched mode power supply and therefore the ability to divert energy is small. The resistances in the first computer load are not present in the simulation. In the simulation a lot of high frequency components are detected.

### 2.3.1.3 Comparison between measurements and simulations

The difference in the results is explained by the fact that the entire circuit is not present in the simulation circuit and therefore the damping is not so distinct as in the measurements. The high frequency components are not visible in the measurement. It is obvious that the comparison between measurements and simulations becomes more complicated with only one additional computer. It is clear that load present on the same feeder is damping the transient to a large extent.

## 2.4 Current measurements and simulations of one computer.

### 2.4.1 Laboratory supply network

The current measurements and simulations are performed with one computer in the laboratory supply network. The current measurements were performed with a 200 MHz digital oscilloscope.

### 2.4.1.1 Measurements

The current measurement for one computer is shown in figure 2.23. The initial current transient reaches a value of 20 A, and has a duration of 0.5 ms. This measurement shows a current transient not far from the voltage zero crossing. Several frequencies are present in the high frequency oscillation.

When the maximum inrush current was measured with a digital oscilloscope the level of the current reached almost 40 A, see figure 2.24. It was shown that the worst possible inrush current reaches above 50 A.

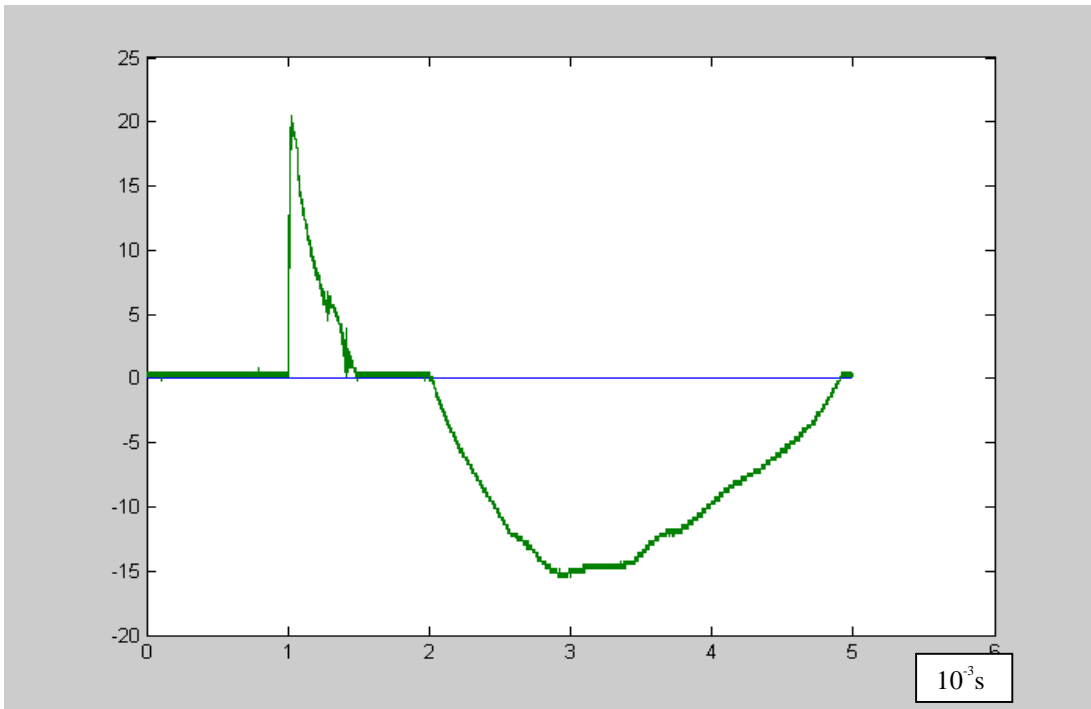


Figure 2.23 Current transient due to computer switching, one computer, measurement.

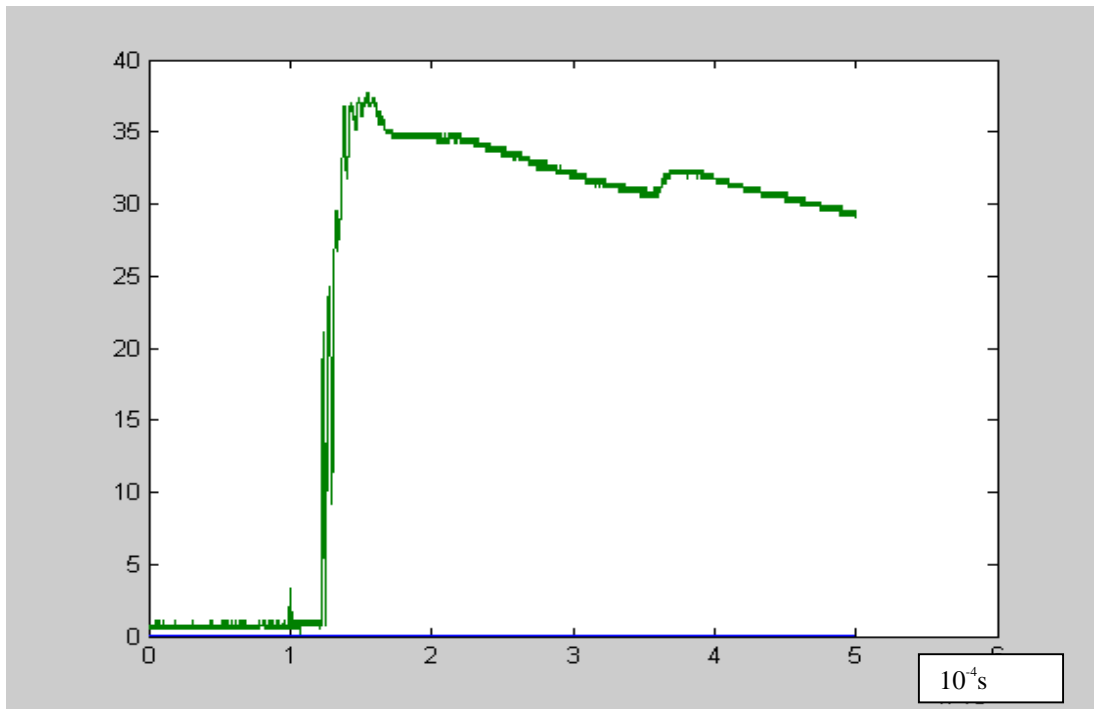


Figure 2.24 Detection of maximum inrush current

#### 2.4.1.2 Simulations

The simulating circuit is in figure 2.4. The current transient is shown in figure 2.25. The initial current transient reaches a value of 16 A and has a duration of 0.8 ms. The enlarged curve in figure 2.26 shows the high frequency oscillation present in the transient. Figure 2.27 shows the large spectrum of frequencies in the oscillation.

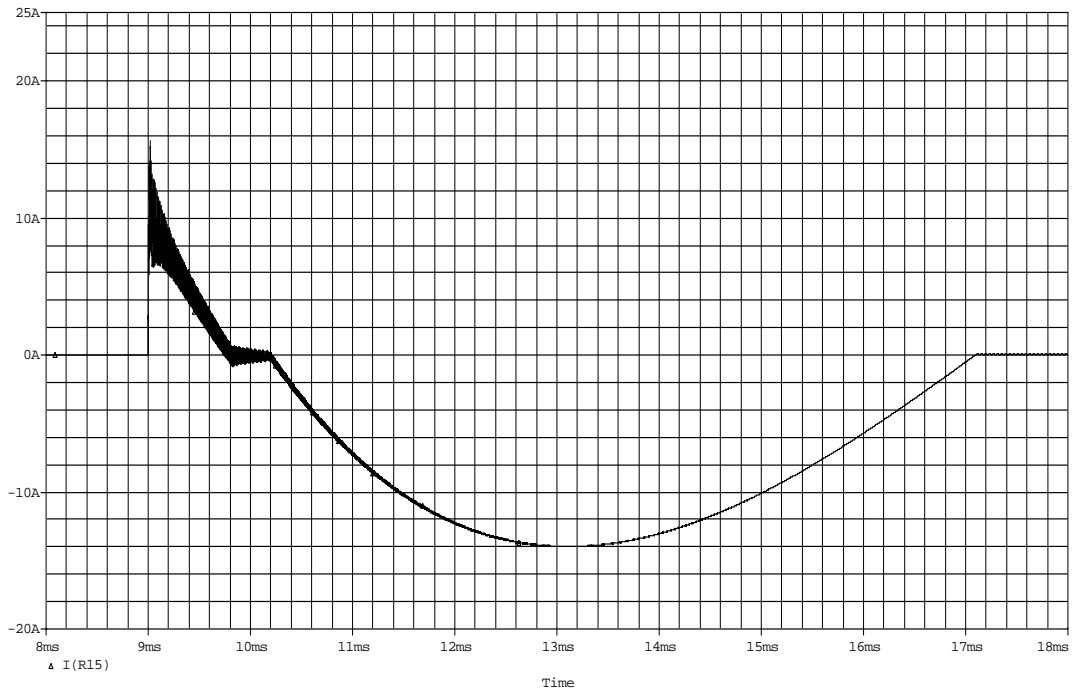


Figure 2.25 Current transient due to computer switching, one computer, simulation

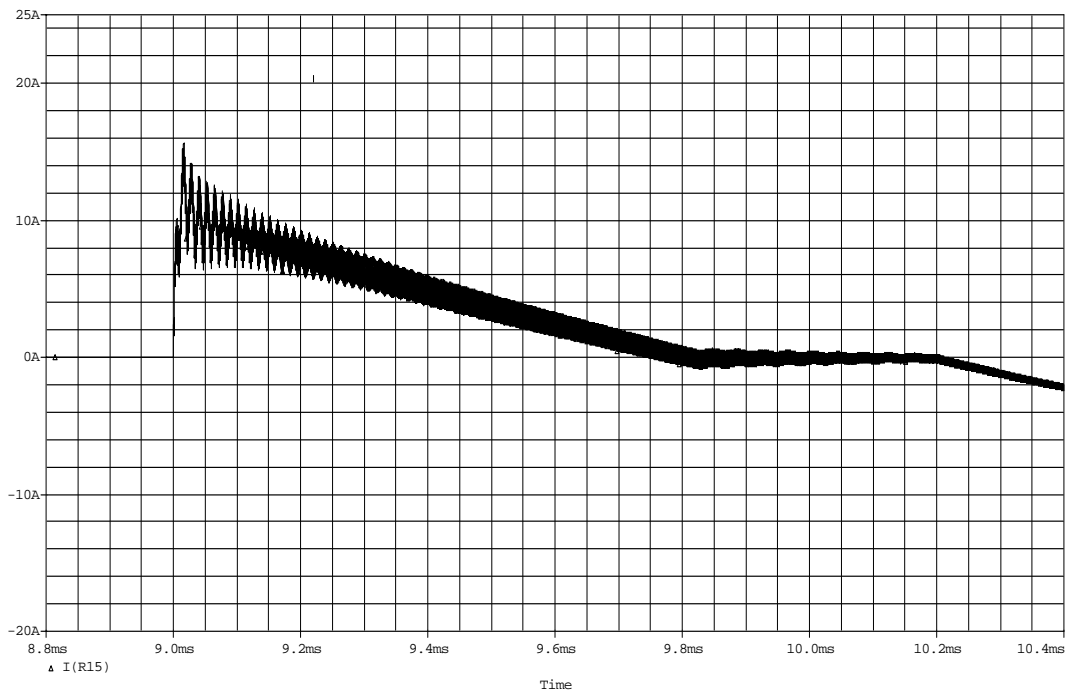
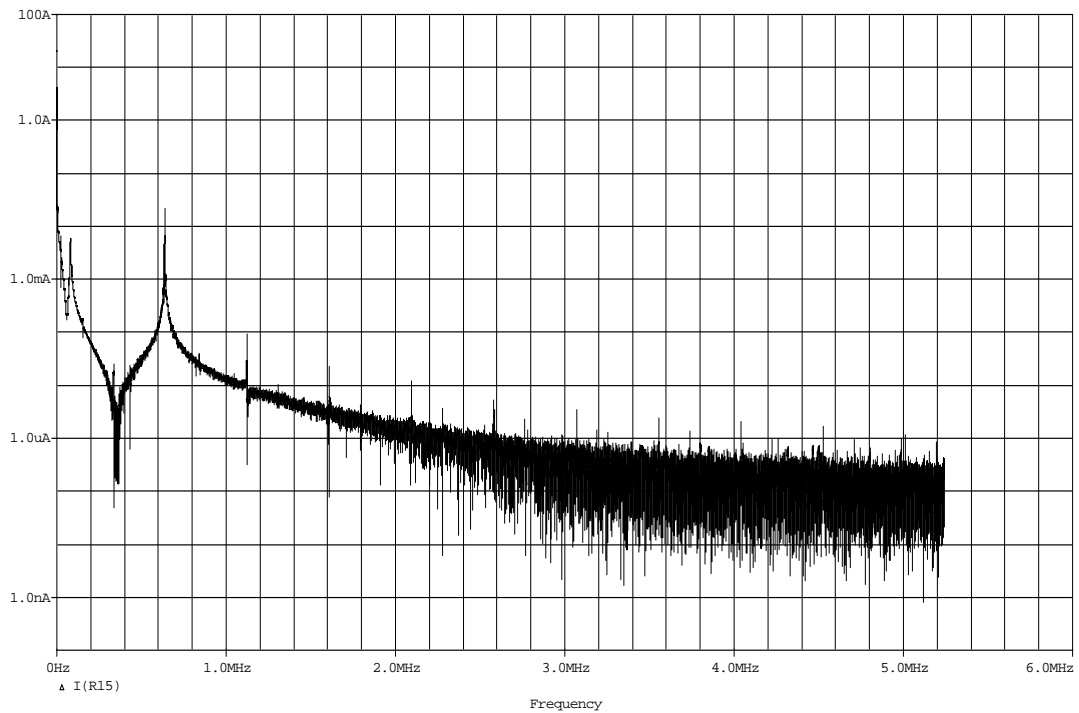


Figure 2.26 Current transient due to computer switching, one computer, simulation, enlarged



**Figure 2.27** Frequency analysis of the simulation

#### 2.4.1.3 Comparison between measurements and simulations

The characteristics for the measurements and the simulations are corresponding. After some oscillations the current decreases to its operating value, which is approximately 0.4 ampere for one computer. The maximum inrush current is reached when the energizing of the computer is performed at voltage maximum. Simulations show that the maximum inrush current reaches above 50 A. To achieve maximum inrush current from measurements is possible only by energizing the computer exactly at voltage maximum.

### 2.5 Current measurements and simulations two computers

The measurements and the simulations derived from the current measurements with two computers show that the inrush current is not damped by the existing load on the feeder. The maximum current transient value from the simulations when the second computer is energized at voltage maximum shows a current above 50 A.

## 2.6 Conclusions

For the voltage transients the measurements and the simulations show a difference up to a factor 1.4. The initial voltage transients reach high values. The differences in the results between the strong and weak power supply system are small. There are no indications that the existing load in the office supply network is absorbing the transient energy, but the load present is affecting the oscillating frequency. *The measurements with a two-computer load are indicating that load has to be located at the same feeder to have any influence on the transient amplitude and damping.* Here it is obvious that the load is absorbing energy from the transient. The high frequency component in this case is depending on the impedance in the cable between the two computers and the capacitance in the switched mode power supply. The simulating circuit is well applicable to studying the initial transient behaviour for the tested circuits.

For the current transients the main behaviour is similar between the measured and the simulated circuit. The transient currents are comparable.

The maximum inrush current for one computer reaches a high value, and there are reasons to believe that energizing of many computers simultaneously is hazardous.

A possible cause of the difference in measurement and simulation is the influence other loads have on the oscillation frequency.

The simulation circuit is a switched mode power supply used in normal electric equipment such as TV receivers. This means that the simulation method can be used for transient behaviour from other circuits besides computers. It is obvious that the network quickly become complicated and difficult to analyse just by comparing the results for the measurements and simulations for one and two computers respectively. One of the most important conclusions is that ordinary computer load may generate severe voltage and current transients when energized.



### 3 Field measurements

#### 3.1 Background

The field measurements are performed to show some examples of typical transients. It has been shown that 65% of the transients occurring in a house is origination from within the building and only 35% have their origin from outside the building. [34].

##### 3.1.1 Measurements

In this chapter voltage transients are considered. The single phase measurements were performed with a Medcal power quality monitor and the three phase measurements were performed with a Dranetz 658 power quality monitor.

#### 3.2 Measurements in domestic environment

##### 3.2.1 Kitchen measurements

The measurements were recorded in a kitchen. In 47 days 336 transients were recorded. Not all of the transients were so severe as the ones shown in the figures below. Higher frequency oscillations in the transients are not recorded by the measuring equipment. Figure 3.1 shows a switch-on action of an electric mixer. The transient has amplitude of 150 V and duration of a few milliseconds, and a peak-to-peak value of 170 V. This is a typical transient in a domestic environment regarding duration and amplitude.

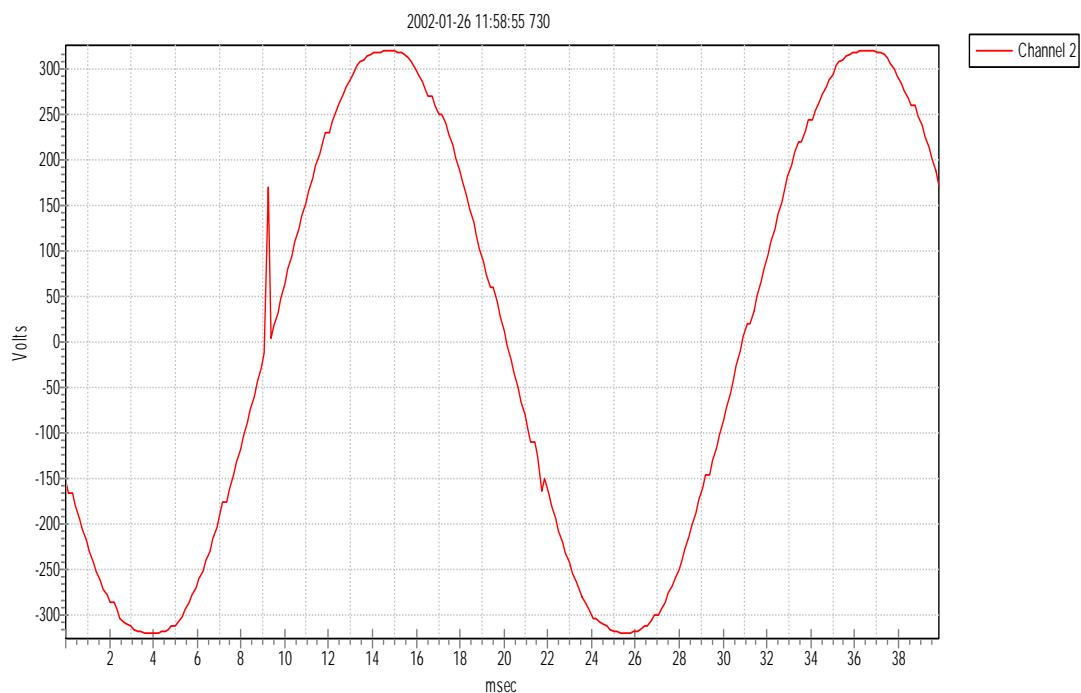
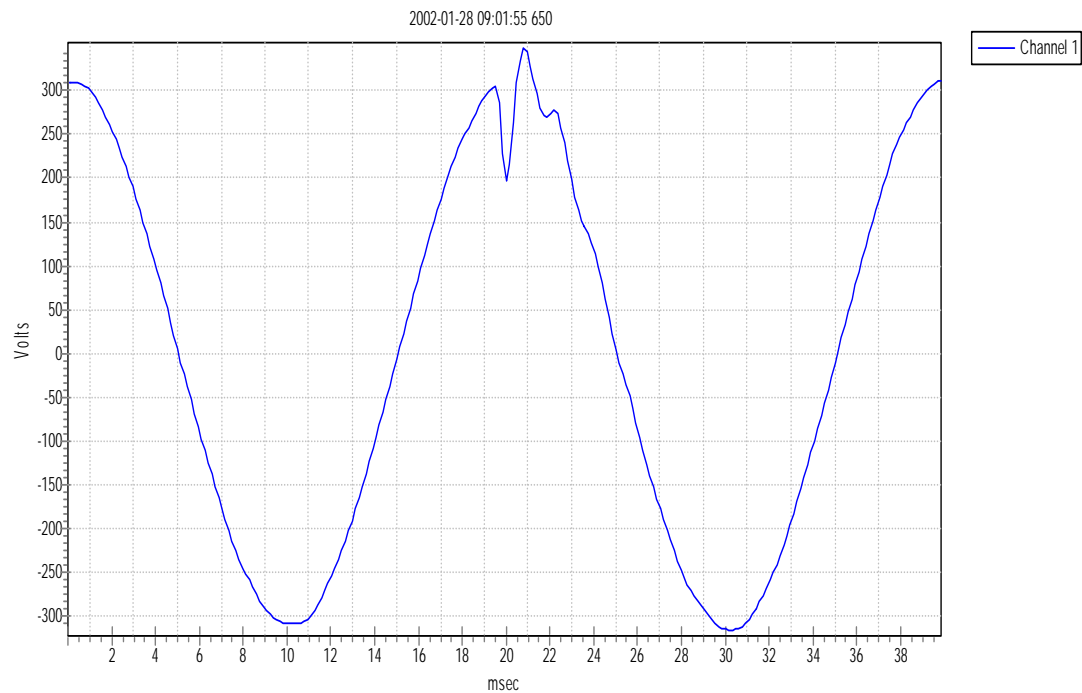


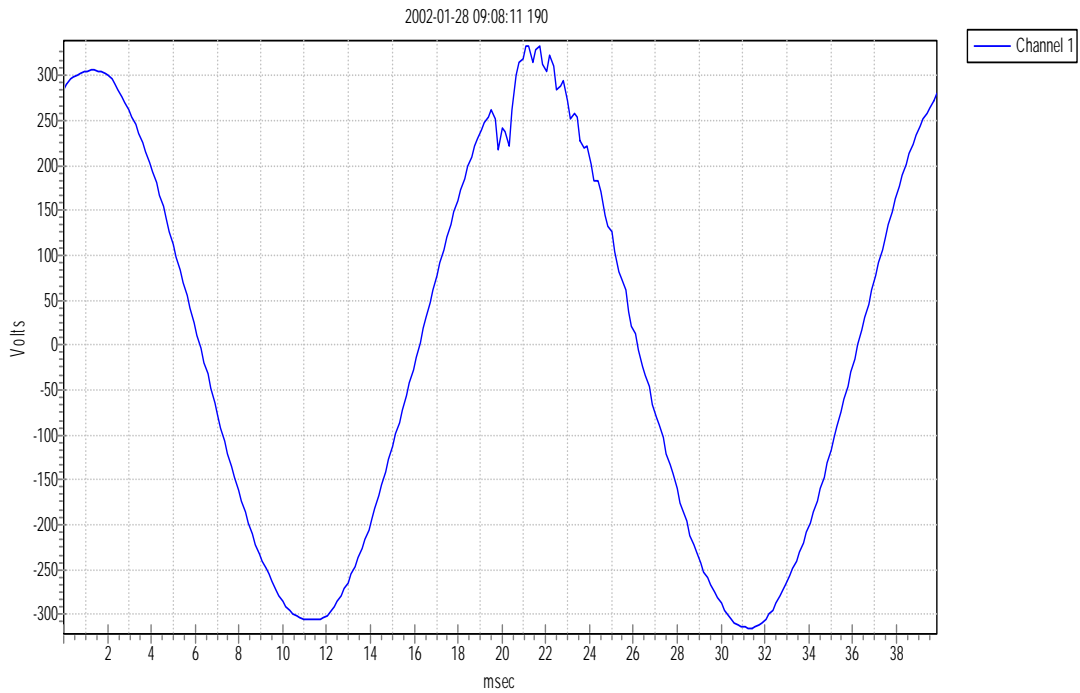
Figure 3.1 Electric mixer, Medcal power quality monitor.



**Figure 3.2 Microwave oven, Medcal power quality monitor.**

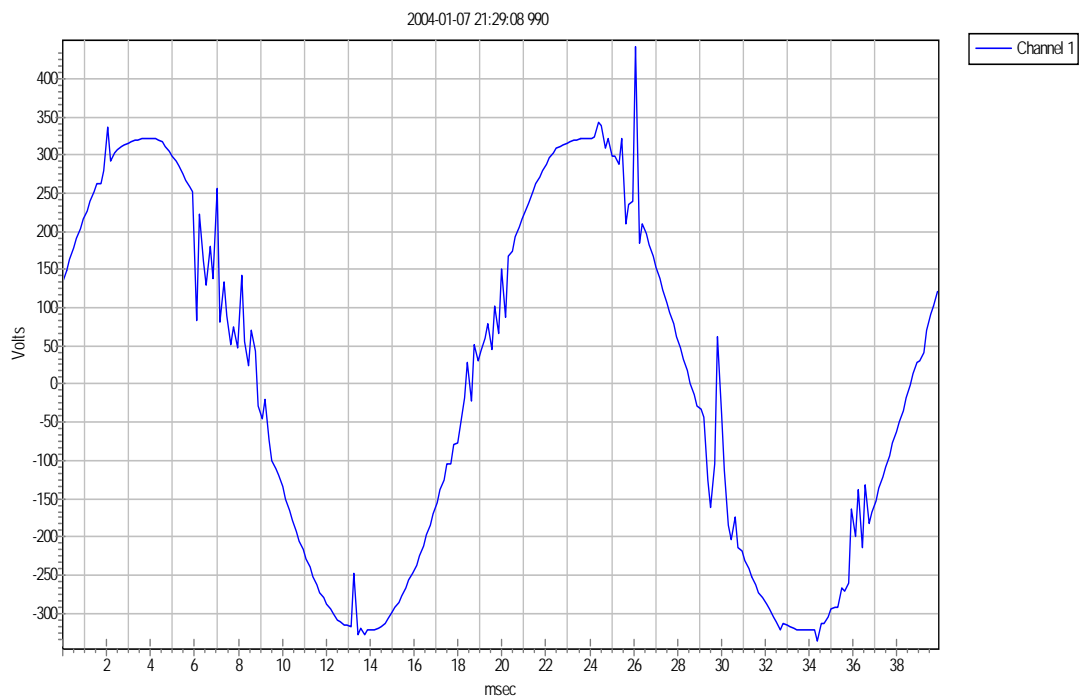
Figure 3.2 shows another transient recorded at the same location. This transient is due to a switching-on action of a microwave oven. The maximum value reaches 340 V and the peak-to-peak value is 150 V. The duration is approximately 2 ms. There are a number of high-frequency components in this transient not recorded by the measuring equipment.

Figure 3.3 shows the energizing of a fluorescent lamp in the kitchen. This transient has a maximum value of 345 V and duration of about 6 ms. This transient looks more like a noise disturbance on the sinus wave. As shown in the previous figures the transients can have a different character for different actions, depending on the circuit in action but also depending on load present in the power system. Therefore it is not possible to categorise different transients by only looking at measurements. It is obvious that all the equipment in a household is contributing to the disturbance level by creating transients and high frequent noise.



**Figure 3.3** Fluorescent lamp, Medcal power quality monitor.

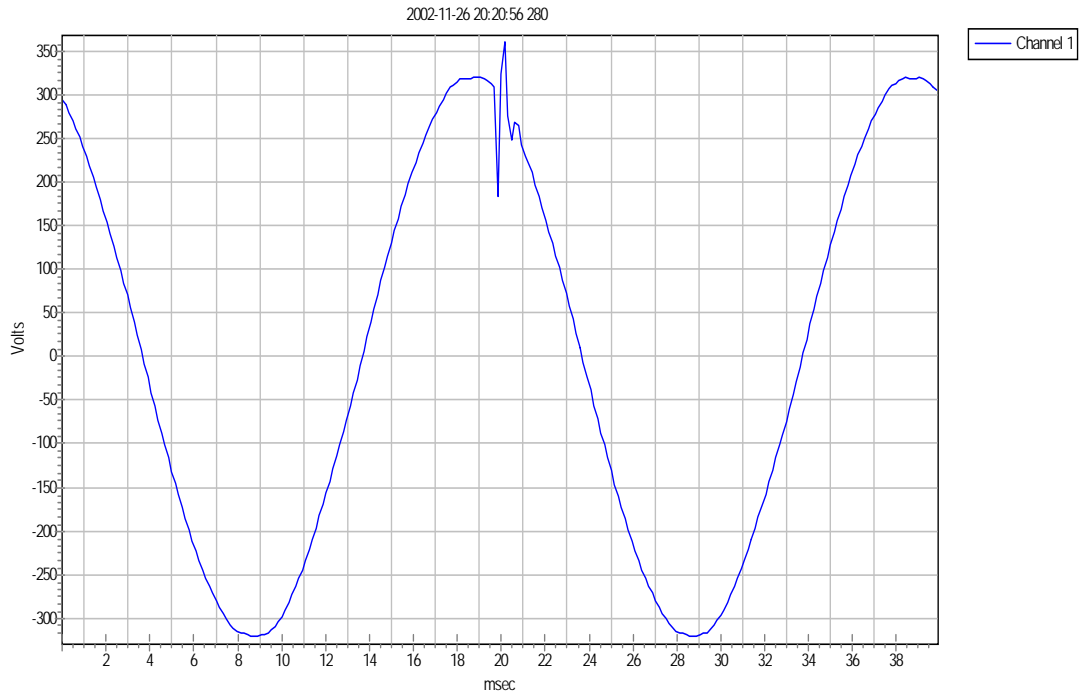
Figure 3.4 shows a measurement taken in the kitchen at a time when no one was in the building. The transients are caused by an event outside the building. The max value of the transient is 390 V whereas its peak-to-peak value is 220 V. These types of repeated transients are not common in the measurements and therefore there is probably a fault somewhere in the power system that has caused them. The power system where these measurements were taken is located in a rural area where the grid is weak.



**Figure 3.4** Event outside building

### 3.2.2 Living room measurements

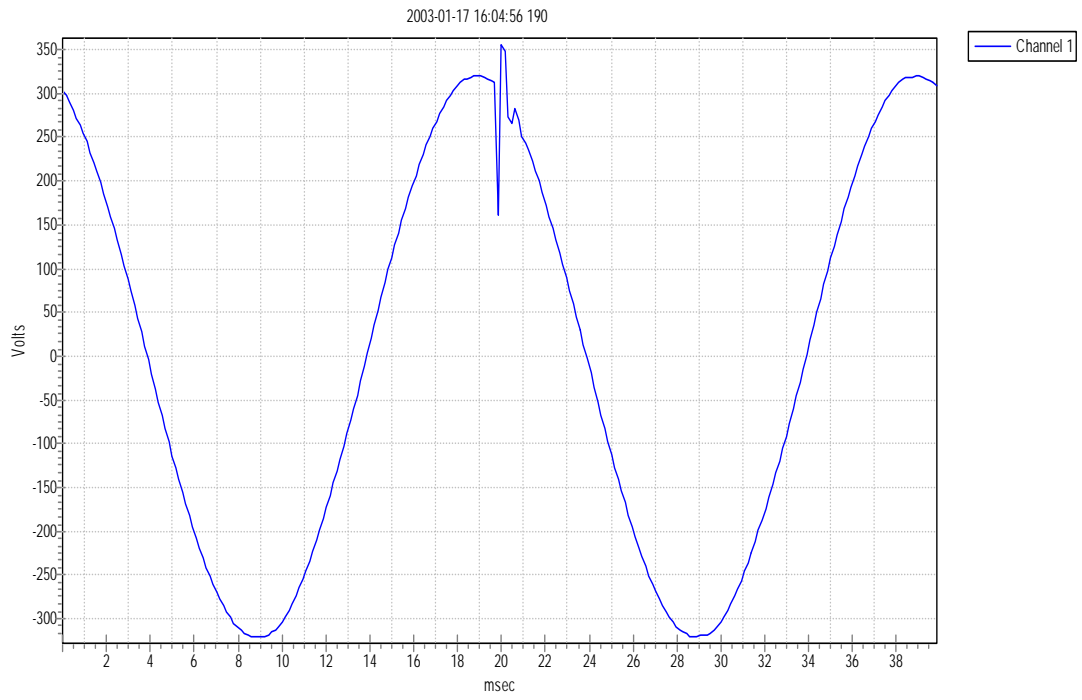
These measurements are recorded in a living room. In 37 days 26 transients were recorded. The main load in the living room consisted of a TV, a stereo and a computer besides incandescent lamps. Not all load is located at the same feeder. Figure 3.5 shows a transient for a switching on action of a TV. This transient reaches a value of 370 V and has a peak-to-peak value of 200V. The duration is 1.5 ms.



**Figure 3.5 TV switching, Medcal power quality monitor.**

### 3.2.3 Basement measurements

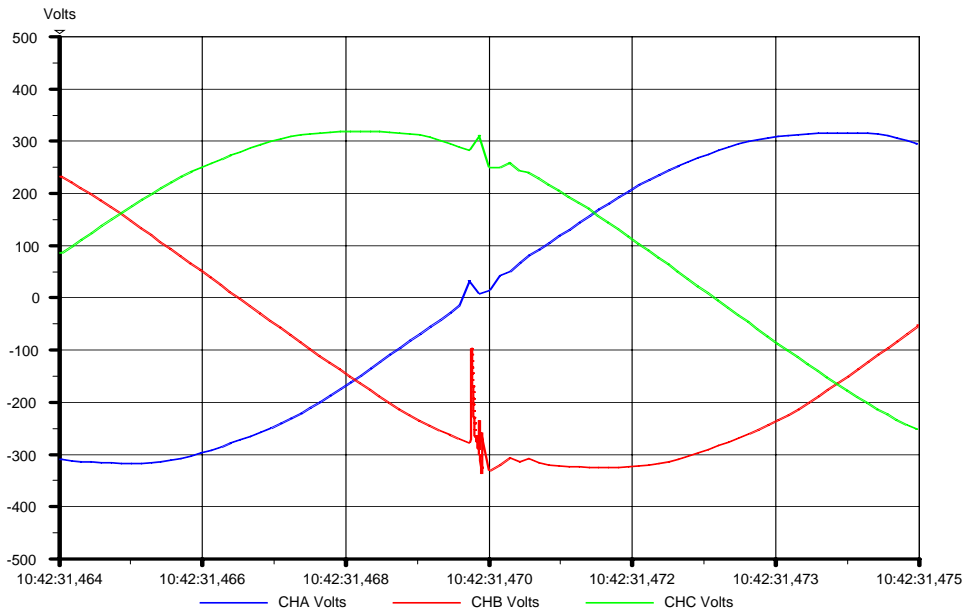
The following measurements were recorded in a basement of a residential building. The largest load in the basement is a pump used for the indoor swimming pool. In 14 days 23 transients were recorded. The transient in figure 3.6 reaches a value of 360 V and has a peak-to-peak value of 190 V. The duration is 1.5 ms.



**Figure 3.6 Pool pump, Medcal power quality monitor.**

### 3.2.4 Three phase measurement

The measurement in figure 3.7 shows the energizing of a heat pump. The main transient is in phase B, but minor transients are visible in the other two phases. The transients in the other two phases are due to the mutual coupling between the two phases. This transient has a peak-to-peak value about 170 V and duration of a few milliseconds.



**Figure 3.7** Heat pump, Dranview 658 Power Quality Monitor

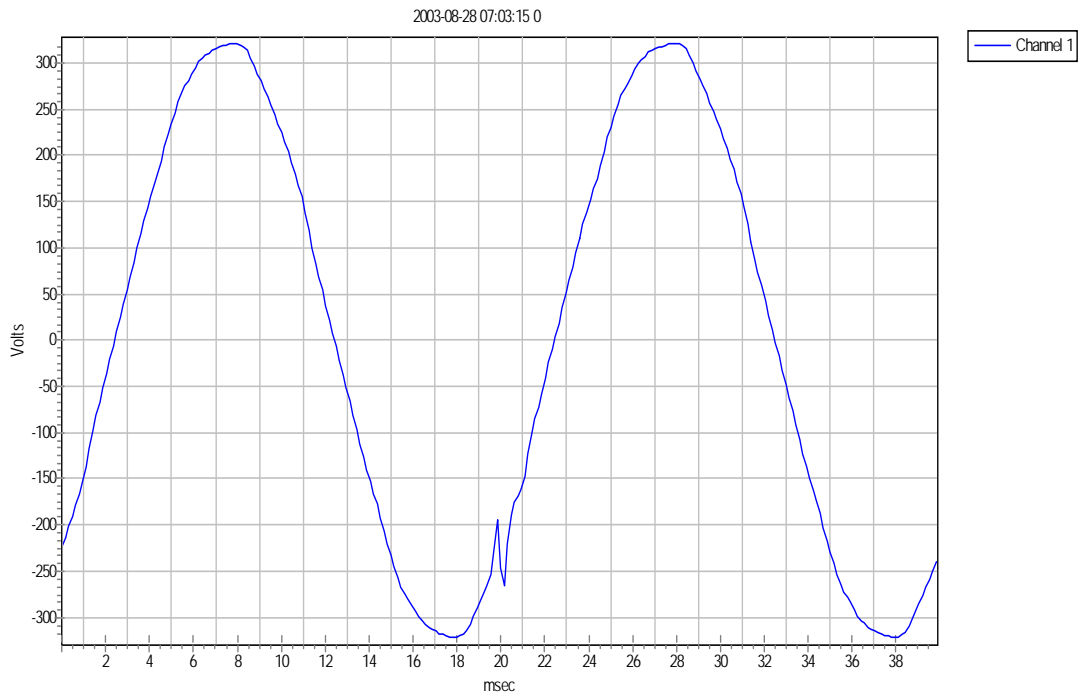
### 3.2.5 Voltage transients in domestic environment, conclusions

Voltage transients of different character, amplitude and duration can be expected in a residential environment. As the transients are damped fast over distance the equipment that experiences the transients is those equipment located close to the transient origin. The largest number of transients was generated in the kitchen where kitchen appliances are used. When these machines are used they generate a lot of switching actions. In the remainder of the building the load is more constant, and therefore the generation of transients is smaller. Some transients are originating from outside the building and can be caused by faults or by switching actions in the network. Most of the transients are due to normal switching actions in the building. This is also proved by the fact that the number of transients recorded is much lower at times when no one is in the present building.

### 3.3 Measurements in official environment

#### 3.3.1 Office measurement

These measurements are recorded in an office building with computers as main load. In 12 days 57 transients were recorded. The point of measurement was at the same feeder as other computers were located. Therefore most of the transients have characteristics like the example in figure 3.7. The transient has a peak-to-peak value of 70 V, and duration of about one millisecond. The largest part of the load, the computers in the office, is either in stand-by mode or used. This is the reason why the transients are relatively low amplitude transients. Other switching actions in the network can cause more severe transients. Flourescent lamps have a lot of high-frequency components polluting the network.



**Figure 3.8 Computer energizing, office environment, Medcal power quality monitor.**

Measurement in medium and high voltage networks are not discussed here. Focus on these measurements will be in the future work.

### **3.4 Conclusions**

Severe transients can be produced in both residential and official environment, but the most severe transients appear to be coming from outside the building. From these transients most residential buildings lack protection. To be fire proof, all existing and older electric installations should be equipped with lightning and transient protection. All the new electronic equipment that is bought and installed in the systems is more sensitive to transient disturbances than the older equipment. There is transient protection equipment available that reduces the incoming voltage to levels durable for the new apparatus.

Regarding the immunity level against transients for equipment little information is available. The insurance companies are interested in reducing the damages, as a fire can occur weeks after a lightning strike. Experts agree that lightning protection is needed in residential buildings [24].



## 4 Evaluation of questionnaire

### 4.1 Background

During the spring of 2000 a questionnaire was sent out to approximately 100 Swedish industrial companies with different lines of business. The questions concerned the electrical system, the power consumption and power quality issues with the emphasis on high frequency disturbances. The questionnaire was used to find out how transients affect the supply voltage and what kind of malfunctions they might cause. Equipment damages and production shut-downs are two serious consequences of these disturbances. Such events can generate large financial costs for the affected companies. It is therefore of importance to further investigate the cause and origin of the disturbances. The goal is to mitigate or eliminate the effects of the disturbances.

### 4.2 Introduction

Equipment mal-operation due to bad power quality is an issue that comes up regularly in discussions between electricity companies and their industrial or commercial customers. The equipment problems due to voltage dips and short interruptions are well documented [25], [26], but no clear picture exists of the problems due to higher frequency disturbances like transients. To get a clearer picture, and to find possible cases for further investigation, a questionnaire was sent out to different industrial companies in Sweden. The purpose was to find out how transients affect the electricity supply and what type of malfunctions that may occur. Disturbances are difficult to categorize and malfunctions can be the result of different types of phenomena besides transients, for example voltage dips or harmonic distortion.

The entire questionnaire is presented in Appendix C. The response frequency was about 30%. About 50% of the industries had little or no trouble at all with their electricity supply. Some had problems once or twice a year and others had weekly problems in some parts of the production. The reason for these problems cannot always be explained, though many respondents related their production outages to thunderstorms.

### 4.3 Industrial power systems

#### 4.3.1 Lines of business

The plants investigated have different lines of business such as manufacturing industry, paper industry, ironworks, chemical industry, timber industry, electronics industry, but also real estate management and hospitals. Figure 4.1 shows the distribution of the lines of business among the companies.

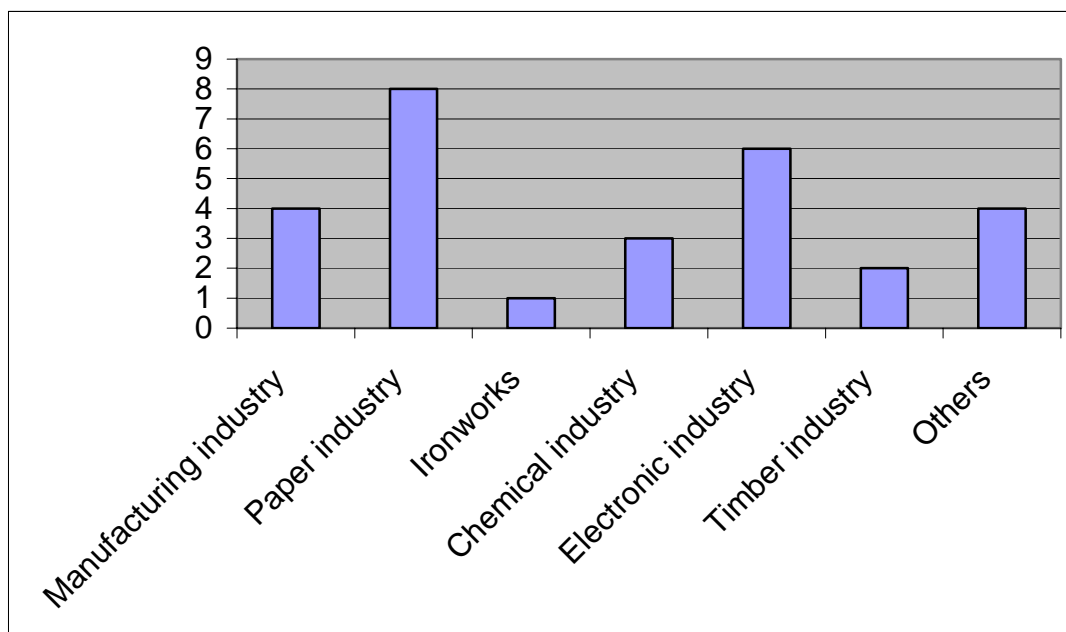


Figure 4.1 Lines of business in the questionnaire

#### 4.3.2 Contracted voltage levels

The contracted voltage levels vary between 0,4 kV and 130 kV for the different industries. Those who are contracted for 0.4 kV are mostly electronic industries. At the 10 kV level there are manufacturing industry and timber industry. Large paper industries are often contracted for 130 kV. The industries contracted for the highest voltage level are not automatically the largest energy consumers, as some of the industries contracted for 10 kV have higher energy consumption than the ones contracted for 130 kV. Figure 4.2 shows maximum load versus contracted voltage levels for the different industries.

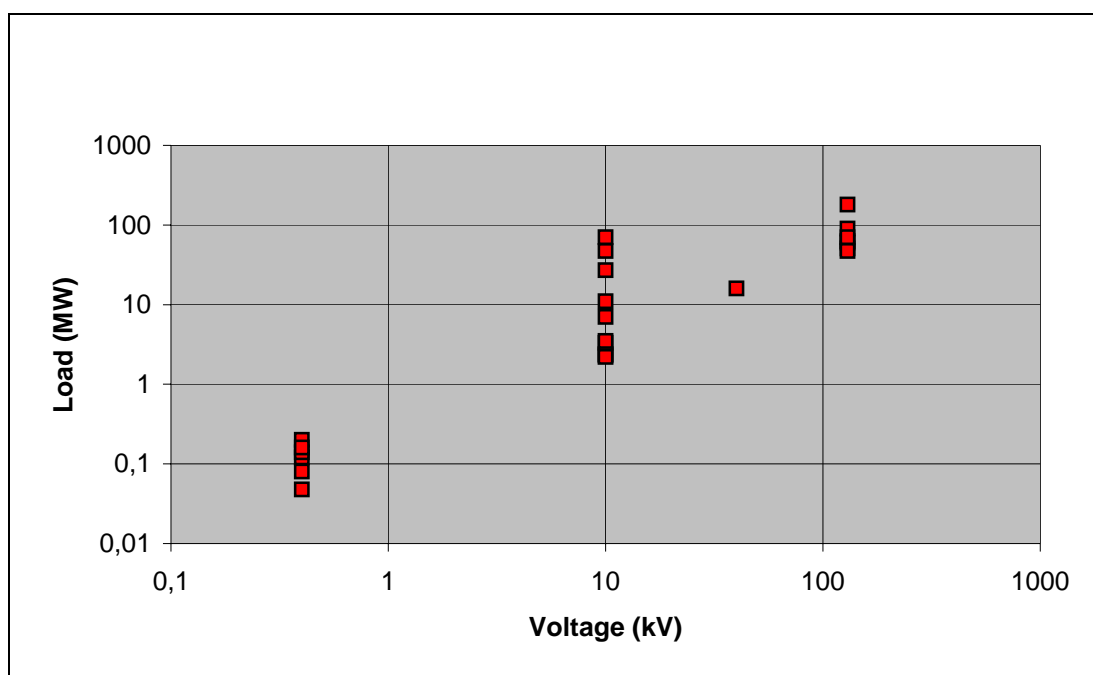


Figure 4.2 Maximum load and contracted voltage level

#### 4.3.3 Load characteristics

The maximum load varies from 12 kW to 180 MW. The annual consumption of energy lies between 90 MWh and 1240 GWh. Those consuming much energy are paper industries and ironworks, while electronic industries are low energy consumers.

#### 4.3.4 Conductor systems

Most of the industries have mixed four-wire and five-wire systems in their plants. Some have five-wire systems in the newer parts of the plant and four-wire system in the older parts. Others have four-wire system between distribution buses and five-wire systems between different apparatus in the plant. Only about 15% of the industries have five-wire systems in the whole plant. These are an electronic industry, an engineering industry, one hospital, and industries for manufacturing drugs and paper. The drug manufacturing company has problems with tripping of new laboratory equipment. The supplier of the equipment is blaming the conductor system for the failure. The remainder of the industries with five-wire systems have almost no trouble at all with their electrical system. Whether this fact is related to the five-wire installation cannot be determined by this investigation, as most of the industries with four-wire installations do not report any trouble either.

No questions were asked concerning 50 Hz-fields or magnetic fields. These fields are more common in four-wire installations due to stray currents, when the current instead of going in the return cable flows through heat conduction

pipes or water pipes. Magnetic fields that occur around these pipes can sometimes cause disturbances [27].

#### 4.3.5 Redundancy and reserve power

Almost 60% of the plants have some level of redundancy in their system. Two of the plants, one hospital and one paper industry, have reserve power units to support the whole plant. Several of the plants have a partial reserve power supply for computers and lighting. Some of the industries use UPS for computers. Approximately one third of the industries have no reserve power at all. The most common types of reserve power supplies are diesel-generators, gas turbines and battery-packs. Figure 4.3 shows contracted voltage level versus redundancy level. The most common combination is some redundancy in the system combined with partial reserve power. The industries contracted for 0.4 kV have no redundancy or reserve power.

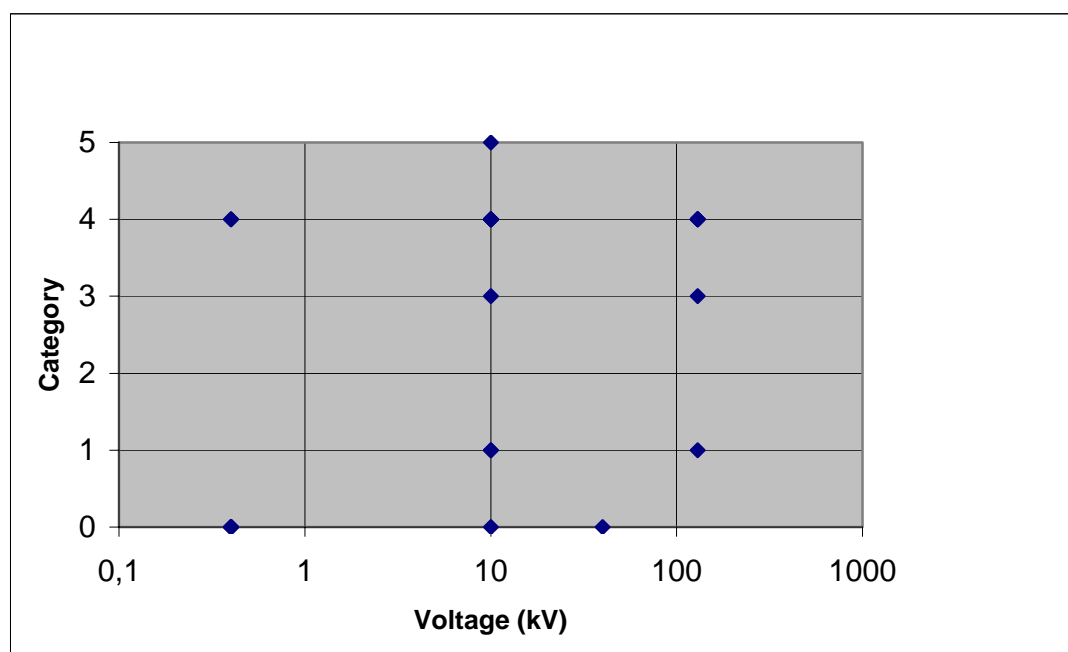


Figure 4.3 Contracted voltage level and redundancy/reserve power

Category:

0: No redundancy, no reserve power (6 at 0.4 kV)

1: No redundancy, partial reserve power (2 at 10 kV)

2: No redundancy, full reserve power

3: Redundancy, no reserve power

4: Redundancy, partial reserve power

(2 at 0.4 kV, 7 at 10 kV, 5 at 130 kV)

5: Redundancy, full reserve power

## 4.4 Power quality concerns

### 4.4.1 Disturbances and interruptions

Many of the reported power quality problems are related to lightning strokes. Several of the paper industries report long production outages caused by lightning strokes. Production outages of 10 to 15 hours have been reported, occurring up to seven times per year. About half of the plants have problems with inexplicable disturbances in their power supply. An assumption is that those who have not answered also have problems to some extent, though it is not possible to estimate the numbers. Already the number that have problems are large and this calls upon further investigation.

The high frequency disturbances are most likely originating within or close to the plant, as these disturbances are quickly damped and do not travel far. One investigation shows that 60% of the voltage transients are originating within the plant [8]. However some of the disturbances originate from higher voltage levels and propagate through the network. Some of the plants in the investigation are performing measurements to investigate the cause of the disturbances. Out of the 14 plants that have reported inexplicable disturbances only 4 are investigating the causes. Problems reported due to disturbances in the network are:

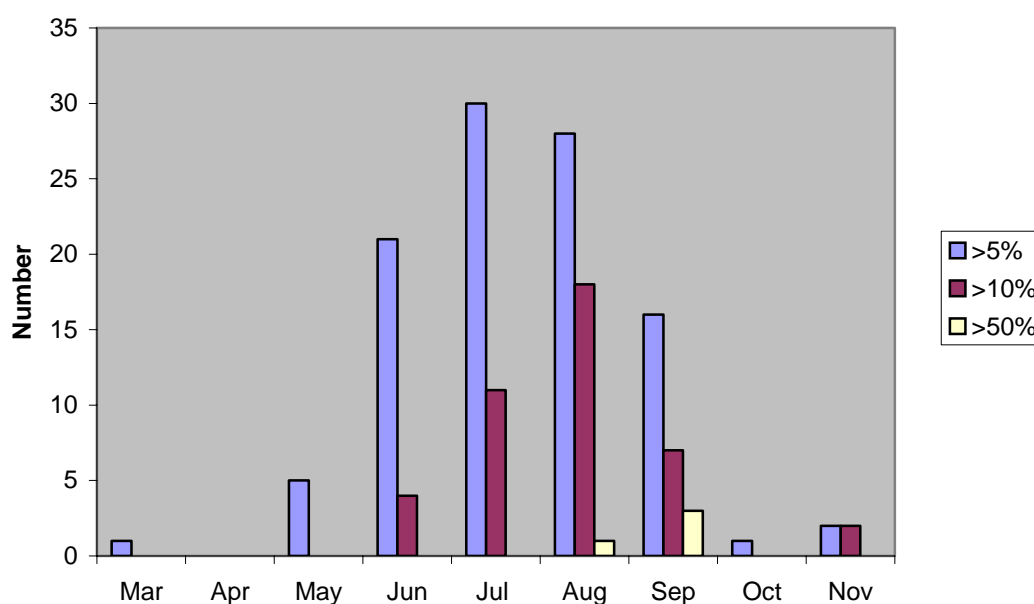
- Machines tripping once or twice a week (3)
- Electronic circuitry is damaged regularly (4)
- Problems with engine-drives (2)
- Tripping of frequency converters (3)
- Computers (without UPS) are damaged (2)
- Laboratory equipment is damaged (2)
- Capacitors are damaged (1)

The number of plants experiencing each disturbance is shown in brackets. Some of the plants have more than one kind of disturbance. Not all these problems are due to high-frequency disturbances. The tripping of frequency converters is probably caused by voltage dips [25]. Transients caused by capacitance charging can affect frequency converters [28], but synchronized switching of capacitor banks is commonly used in Sweden. Malfunction of rotating machines can be caused by harmonics [28], while damage to electronic circuitry and computers are more likely due to transient overvoltages.

### 4.4.2 Lightning related problems

Several respondents mentioned equipment maloperation during periods of lightning activity. A lightning stroke induces a large overvoltage on the line. If the voltage exceeds the insulation withstand level it results in a short circuit, otherwise the voltage peak will start to propagate through the system. If the peak voltage is not high enough to cause a flashover on the line, it might still

trigger a spark gap or (ZnO) varistors. A spark gap mitigates the overvoltage by creating a temporary short circuit, which in turn causes a dip for one or two cycles. A varistor will only cap the overvoltage. One conclusion from one of the first power quality surveys [29] was that the number of voltage transients did not increase in areas with more lightning; instead the number of voltage dips increased. A nearby lightning stroke can induce overvoltages that damage equipment [26], but another likely chain of events is that a direct stroke to a transmission line or tower leads to a flashover resulting in a short circuit. End-user equipment experience a voltage dip during the short circuit. Several large monitoring surveys show a clear increase in the number of voltage dips during summer when lightning activities are at its peak [30]. In one investigation [31] registration of voltage sags have been performed in different stations all over Sweden on VHV and HV levels. The occurrence of voltage changes as voltage dips or interruptions from six 400/220 kV stations are shown in fig 4.4. The bars are ranging different levels such as >5%, >10%, and >50% drop in voltage. All events have duration >10 ms. These measurements were performed during 8 to 10 months. This measurement strongly indicates more voltage dips during summer and early autumn when lightning activities are high. The different investigations show that maloperations due to lightning activity both can be caused by transient overvoltages and voltage dips, but the most common cause seems to be voltage dips. The cause in every special case can sometimes be decided by examining the damages. The damaging effects for voltage dips versus voltage transients have not been investigated.



**Figure 4.4 Occurrence of voltage dips and interruptions from registration during 8-10 months in six 400/220 kV stations in Sweden.**

## 4.5 Conclusions

The questionnaire shows that there are problems with power quality in the Swedish industry. One of the conclusions is that a number of plants more or less accept a certain amount of disturbances in the power supply. Only a few of the plants in the questionnaire perform measurements to locate the reason for the disturbances. The problems can sometimes be easily fixed as restoring a fuse, while sometimes a machine is damaged and the whole production process is stopped. *Most likely the companies are not aware of the economic consequences due to these disturbances.*

As high frequency transients do not travel far, it is important to make the customers aware of the fact that the power quality problems often are caused by themselves. By measuring transients it is possible to find out from where the disturbances originate. The majority of the high-frequency disturbances are generated in normal operation and only a small part in exceptional cases such as during short circuit conditions. Many of the production outages can be related to voltage dips due to lightning strikes, but when the voltage is not high enough the peak will start to propagate through the system. How far the peak will travel and how much damage it will cause depends on the system construction. One further goal of this investigation is to perform measurements on 10 kV level and 400 V level simultaneously to find out how transients propagate through the network construction. Another aim is to perform an economic evaluation of the mal-operations related to transient disturbances. This will further illuminate the importance of mitigating and eliminating transient disturbances.





## 5 Conclusions and future work

### 5.1 Conclusions

The main contributions from this project were the measurements and simulation results obtained and the information collected by a survey. The measurements were taken both in a laboratory network with practically no other load present and an office network having mainly computer and lighting load. Transients were registered for the switching of one and two computers. The transient characteristics for the different cases were analysed to find out what affects the characteristics of the transient. The measurement results show that the energizing transient is severe for both networks.

However, the presence of a second computer very close to the one being switched sometimes significantly reduces the severity of the energizing transient. But the characteristics of the most severe transients were not affected.

A questionnaire concerning transients was sent out to about 100 Swedish industrial companies. The questionnaire included questions about the network and the disturbance level in the system. The results shows that quite a number of companies have problems with transients in their networks. The problems range from computer problems to processing interruptions. Most of the companies seem more or less to accept their problems and get around them by regularly resetting a computer or replacing some electronics. Only a few of the companies perform measurements and try to solve the problems. This can be explained by the fact that the real costs due to the loss of production are generally not well known. If those costs were known more effort could be used in finding solutions. In some cases a short transient disturbance of about half a second can cause a production outage for about eight hours.

### 5.2 Future work

There are sufficient indications of damage due to transients to justify further investigation into the subject. At recent meetings of the Swedish industry on power-quality, the subject of transients has resulted into more lively discussion than voltage dips! The current discussions on transients reminds of the discussions on voltage dips ten to fifteen years ago.

Looking at the long-term need for research on this area one can distinguish between the following subjects:

1. Assessment of the costs at the customer side due to damage by transients.
2. Measurements and simulations in different systems to understand the origin and propagation of transients.

The continuation of this project will consist of three parts: the economic consequences of transients, the direct and indirect effect of transients on equipment, and a study of the transients in a three-phase medium-voltage industrial system.

The economic consequences of transients. There are sufficient indications that it is worth to do such an investigation. However a clear quantification of the direct and indirect costs is needed to determine if, and which measures are to be taken. The survey that was conducted during the first part of the project will be used as a starting point for a further investigation into the economic consequences. More detailed discussions will be held with those companies that have indicated problems due to transients. Where needed, dedicated literature surveys will be conducted to obtain relevant information. A rough assessment will be made of the overall costs due to power-system transients in Swedish industry.

Direct and indirect effects of transients on equipment. The economic consequences of transients can in all cases be traced back to the effect transients have on equipment. To fully understand the consequences and possible mitigation methods it is important to understand how transients effect equipment. Within this part of the project an investigation of these effects will be made, based on literature surveys and discussions with customers and manufacturers of equipment. This part of the project will be conducted in co-operation with the “EMC on site” project at Luleå University of Technology. Within the EMC-on-site project it is possible to conduct experiments on equipment to better quantify the direct and indirect effects of transients on equipment.

Measurement and simulation in a three-phase medium-voltage system. This is a common method within power quality to obtain insight in a phenomenon. The same work has been done concerning voltage dips at Chalmers University of Technology and many other universities as well as in industry. The simulation issues will be more complicated for transients because of the wider frequency range involved, but the approach will be similar.

During the first part of this project experiments were performed in a single-phase low-voltage system. This will be extended in the second stage of the project to a three-phase medium-voltage network. As a case study we will use the supply to the port of Gothenburg (“Göteborgs Hamn”) at 10 kV. The main disturbances are due to the switching of drives for large container cranes. Göteborg Energi Nät has installed permanent power-quality monitors to this supply point, the measurement results of which are available to Chalmers University of Technology. Where needed, additional measurements will be done.

## References

---

- [1] Friman, Edward “Proposals for Limits and Responsibility Sharing with regard to Power Quality”, Report no. S94-061 STRI, 1994.
- [2] Chowdhuri, Pritindra, “Electromagnetic Transients in Power Systems”, ISBN 0 86380 180 3, Research Studies Press 1996.
- [3] Kodali, V. Prasad, “Engineering Electromagnetic Compatibility”, ISBN 0 7803 1117 5, IEEE Press, 1996.
- [4] Hasse, Peter, “Overvoltage Protection of Low Voltage Systems”, ISBN 0 85296 781 0, IEE Power and Energy Series 33, 2000.
- [5] Shibuya, Y, et al., “Effects of Very Fast Transient Overvoltages on Transformer”, IEE Proceedings online no.19990425, IEE, 1999.
- [6] Mason, J. S. B., “Transient Protection for High Speed Data Communication Applications”. IEE 1998.
- [7] Martzloff, Francois D., “Coupling, Propagation, and Side Effects on Surges in an Industrial Building Wiring system”, IEEE Transactions on Industrial Applications, vol 26, no. 2, March/April 1990.
- [8] Standler, Roland B., “Transients on the Mains in a Residential Environment”, IEEE Transactions on Electromagnetic Compatibility, vol. 31, no. 2, May 1989.
- [9] McGranaghan, M. F., “Do capacitor switching still cause problems?”, Power Quality Assurance Magazine, Jan/Feb 1998, p.28-33.
- [10] McGranaghan, M. F., et al, “Impact or utility switched capacitors on customer systems – adjustable speed drives concern”, IEEE Transactions on Power Delivery”, April 1992, pp.862-868.
- [11] Sabin, D.D., et al, “Rules-based algorithm for detecting transient overvoltages due to capacitor switching and statistical analysis of capacitor switching in distribution systems”, IEEE Winter Meeting 1999.

- [12] Wagner, V.E., et al, "Utility capacitor switching and adjustable speed drives", IEEE Transactions on Industry Applications, vol.27, no. 4, July/August 1991.
- [13] McCoy, C. E., et al, "Characteristics and measurement of capacitors switching at medium voltage distribution level", IEEE Transactions on Industry Applications, vol. 30, no.6, Nov/Dec 1994.
- [14] Girgis, A. A., "Harmonics and transient overvoltages due to capacitor switching", IEEE Transactions on Industry Applications, vol. 29, no. 6, Nov/Dec 1993.
- [15] Dunsmore, D. M., et al, "Magnification of transient voltages in multi-voltage-level shunt capacitor-compensated circuits", IEEE Transactions on Power Delivery, vol. 7, no.2, April 1992.
- [16] Wagner, V.E., et al, "PWM drive filter inductor influence on transient immunity", IEEE Industry Applications Society Annual Meeting, October 1995.
- [17] McCoy, et al, "Characteristics and measurement of capacitor switching at medium voltage distribution level", IEEE Transactions on Industry Application, vol. 30 , no.6, Nov/Dec 1994.
- [18] Dick, E.P., et al, "Point-on-wave capacitor switching and adjustable speed drives", IEEE Transactions on Power Delivery, vol.11, no.3, July 1996.
- [19] Shipp, D. D. et al, "Power quality and line considerations for variable speed ac drives", Annual Pulp and Paper Technical Conference , June 1994.
- [20] Koval, D.O., et al, "Power quality of small rural industries", IEEE Transactions on Industrial Applications, vol. 29, no.4, July/Aug 1993.
- [21] Arseneau, R., et al, "The effect of supply harmonics on the performance of compact fluorescent lamps", IEEE Transactions on Power Delivery, vol.8, no.2, April 1993.
- [22] Wagner, V.E., et al, "Effects of harmonics on equipment", IEEE Transactions on Power Delivery, vol.8, no.2, April 1993.
- [23] IEEE recommended practice for power and grounding electronic equipment, Emerald Book, IEEE Std. 1100-1999.

- [24] Åkerlund, John, "Beskrivning av immunitetsläget mot transienter och överspänningar i elanvändares elektriska apparater, system och anläggningar", rapport Avbrottsfria Kraftnät UPN AB, 2003-09-15 (in Swedish).
- [25] Bollen, M. H. J., "Understanding power quality problems, voltage sags and interruptions", ISBN 0-7803-4713-7, New York, IEEE Press 1999.
- [26] Dungan, R. C., et al, "Electric power system quality", New York, McGraw Hill 1996.
- [27] Salinas, Ener, "Mitigation of power-frequency magnetic fields", ISBN 91-7291-064-x, Ph.D. Thesis, Chalmers University of Technology, Göteborg, Sweden, 2001.
- [28] Kjellén, Börje, "Driftstörningar inom verkstadsindustrin", Elforsk report 97:24 B, november 1997 ( in Swedish).
- [29] Goldstein, M., Speranza, P.D., "The quality of U.S. commercial AC power", International Telecommunications Energy Conference (INTELEC), October 1982.
- [30] Dorr, D. S. "Point of utilization power quality study results", IEEE Transactions on Industry Applications, vol. 26, no.4, July/Aug 1990.
- [31] Häger, M. et al., "Power quality limits and responsibility sharing in Swedish transmission and distribution system", PQA '97 Europe, June 1997, Stockholm.
- [32] Nättransienter i svensk verkstadsindustri, FOA report e30002-E2, April 1984. (In Swedish)
- [33] Plowman, R.J., EMC & Transients An Introduction, IEE 1998

## *References*

---

## Appendix A

### **Dranetz 658 Power Quality Monitor**

Below the instrument specifications for Dranetz 658 Power Quality Monitor are presented. The evaluation program is called Dran-View.

#### **658 Power Quality Analyzer**

The 658 can be used to monitor power disturbances and harmonics, as well as other sources of disruption like temperature, humidity, and radiated RF noise, making it the ideal tool for field service and site surveys.

#### **Features & Highlights**

- True RMS voltage and current meter
- Scope Mode®, Meter Mode
- Event monitor - report by exception
- Menu driven operation
- Harmonics analyzer
- 50/60 and 400Hz monitoring
- Cycle-by-cycle disturbance capture
- Capture multiple transients and complex waveshapes
- 6000 volt impulse auto range
- Simultaneous channel capture
- Graphic summaries
- Zoom in on events
- Transducer inputs
- Built in 3.5" floppy drive
- Dran-View PC analysis and report writer software

#### Technical specifications

The technical specifications regarding impulse measurements:

Impulse Voltage Range	2.4 to 6120 V peak
Impulse Current Range (probe dependent)	2.4 to 6000 A peak
Impulse Duration	>1 $\mu$ s
Impulse Sampling Rate	1.8432 MHz
Impulse Accuracy	$\pm 10\%$ of reading $\pm 1\%$ of full scale

---

**Instrument configuration for measurement**

Site Descriptor: NATLAB

Actual instrument configuration at 2003-11-20 11:02:57,49

=====

=

**CHANNEL SETUP:**

=====

=

Setup#3	A	B	C	D
Range	OFF	VH	I5	I5
Hi Lim	12.7	250	2.50	2.50
Lo Lim	10.5	200	2.00	0.00
Sens.	0.5	20	0.01	0.07
Imp.	10.0	150	0.25	1.80
Wave	1.0	20	0.02	0.15
Frequency Sensitivity:	0.50 (All channels)			Range: 45-65 Hz

=====

=

**SENSOR SETUP:**

=====

=

Chnl	#1	#2	#3	#4	#5	#6
	#7	#8				
Status	OFF	OFF	OFF	OFF	OFF	
	OFF	OFF	OFF			
Span	55	100	50	60	4095	
	4095	4095	4095			
Zero	-5	0	0	0	0	0
	0	0				
Units	Deg. C	% RH	Vpp RF	V/m	Counts	
	Counts	Counts	Counts			
Sens %	2.0	2.0	2.0	1.7	1.6	3.2
	4.8	6.4				



## Appendix B

### PSpice simulation program

The simulation program used is called PSpice. This program can be used for simulating circuits.

The data sheet is appendix D.

### Parameters for the different networks

Calculation of parameters for the laboratory and office networks.

Laboratory network

Transformer data:  $U_1 / U_2 = 11\text{kV} / 420\text{V}$ ,  $S = 1250\text{ kVA}$ ,  $u_k = 5\%$

From transformer to central: cable 20 m AKKJ 4x70//21.

From central to laboratory: cable 20 m 4x35//16.

Impedance for transformer:

$$\omega L = X = 0.05 (U_2^2 / S) = 7.05\text{m}\Omega$$

$$L_{\text{transformer}} = X / \omega = 22.47\mu\text{H}$$

Cable data is taken from SS 424 14 05

Drift impedance 4x70//21:  $0.443 + j0.076\text{ m}\Omega/\text{m}$

$$L_{\text{cable1}} = (l * x) / \omega = 4.85\mu\text{H}$$

$$R_{\text{cable1}} = (l * r) = 8.86\text{ m}\Omega$$

Drift impedance 4x35//16:  $0.524 + j0.079\text{ m}\Omega/\text{m}$

$$L_{\text{cable2}} = (l * x) / \omega = 5.03\mu\text{H}$$

$$R_{\text{cable2}} = (l * r) = 10.4\text{ m}\Omega$$

Total for laboratory network:

$$L_{\text{transformer}} = X / \omega = 22.47\mu\text{H}$$

$$L_{\text{total-cable}} = L_{\text{cable1}} + L_{\text{cable2}} = 9.88\mu\text{H}$$

$$R_{\text{total}} = R_{\text{cable1}} + R_{\text{cable2}} = 19.26\text{ m}\Omega$$

The capacitance calculation is taken from ABB switchgear handbook.  
 For a 70 mm<sup>2</sup> cable the capacitance, C=0.45μF/m. The capacitance for the other cable is neglected.

$$C_{\text{laboratory}} = l \cdot C = 9 \text{ nF.}$$

Office network

Transformer data:  $U_1 / U_2 = 10 \text{ kV} / 400 \text{ V}$ ,  $S = 800 \text{ kVA}$ ,  $u_k = 5 \%$

From transformer to central: cable 40 m AKKJ 4x70//21.

From central to laboratory: cable 20 m 3x10//1.5.

Impedance for transformer:

$$\omega L = X = 0.05 (U_2^2 / S) = 10 \text{ m}\Omega$$

$$L_{\text{transformer}} = X / \omega = 31.8 \text{ }\mu\text{H}$$

Cable data is taken from SS 424 14 05

Drift impedance 4x70//21:  $0.443 + j0.076 \text{ m}\Omega/\text{m}$

$$L_{\text{cable1}} = (l \cdot x) / \omega = 9.68 \text{ }\mu\text{H}$$

$$R_{\text{cable1}} = (l \cdot r) = 17.72 \text{ m}\Omega$$

Drift impedance 3x10//1.5:  $1.83 + j0.087 \text{ m}\Omega/\text{m}$

$$L_{\text{cable2}} = (l \cdot x) / \omega = 5.5 \text{ }\mu\text{H}$$

$$R_{\text{cable2}} = (l \cdot r) = 36.6 \text{ m}\Omega$$

Total for office network

$$L_{\text{transformer}} = X / \omega = 31.8 \text{ }\mu\text{H}$$

$$L_{\text{total-cable}} = L_{\text{cable1}} + L_{\text{cable2}} = 15.18 \text{ }\mu\text{H}$$

$$R_{\text{total}} = R_{\text{cable1}} + R_{\text{cable2}} = 54.32 \text{ m}\Omega$$

The capacitance calculation is taken from ABB switchgear handbook.  
 For a 70 mm<sup>2</sup> cable the capacitance, C=0.45μF/m. The capacitance for the other cable is neglected.

$$C_{\text{office}} = l \cdot C = 22.5 \text{ nF.}$$

## Appendix C

The questionnaire that was sent out to the industrial companies is presented below. The questionnaire was in Swedish.

### The questionnaire in Swedish (Enkäten på Svenska)

#### Elnätet

- 1 Vilken spänningsnivå abonnerar ni på?
- 2 Vilka spänningsnivåer finns i nätet?
- 3 Vilken typ av jordning används i nätet? Ange om det är olika för olika spänningsnivåer.
- 4 Finns det redundans i någon del av nätet?
- 5 Är det 5-ledarsystem i hela anläggningen? Om inte, ange vilken typ av ledarsystem det är.
- 6 Ange elleverantör.
- 7 Ange nätägare.
- 8 Ange maxbelastning.
- 9 Uppge elförbrukningen under ett år.
- 10 Bifoga en schematisk skiss av ert nät.

#### Störningar/Avbrott

- 1 Hur ofta drabbas ni av oplanerade driftavbrott?
- 2 Ange orsaken till dessa driftavbrott.
- 3 Uppskatta längden av dessa driftavbrott.
- 4 Hur ofta har ni planerade driftavbrott?
- 5 Uppskatta längden av dessa driftavbrott.
- 6 Händer det att ni drabbas av 'oförklarliga' störningar som inte kan förklaras av yttre påverkan?
- 7 Om så är fallet, uppskatta hur ofta.
- 8 Har ni problem med att viss utrustning går sönder utan att ni kan förklara varför, eller har ni onormalt kort livslängd på vissa komponenter? Vilka komponenter och vilken utrustning gäller det?
- 9 Drabbas ni av att viss utrustning går sönder vid driftsituationer som ni kan förklara, till exempel extrema driftfall i den egna anläggningen eller från yttre påverkan från annan närliggande industri?
- 10 Känner ni till om närliggande industrier har samma typer av störningar som ni?

#### Lasten

- 1 Vilken typ av last matas från nätet? (Ange andelar i procent)
  - Konstant
  - Varierande (sekunder)

- Varierande (minuter)
- Varierande (timmar)
- 2 Ange driftsituation:
  - Drift dagtid
  - Drift dygnet runt
  - Annat (ange vad)
- 3 Vilken typ av last finns i nätet?
  - Motorer (mellanspänning)
  - Motorer (lågspänning)
  - Ljus
  - Elvärme
  - Last med likriktare
  - Annat (ange vad)
- 4 Annan information om lasten.

#### Förebyggande åtgärder mot störningar

- 1 Har ni reservkraftaggregat för hela/delar av anläggningen?
- 2 Ange typ och storlek.
- 3 Har ni någon typ av filter installerade i anläggningen till exempel övertonsreducering eller spärrfilter?
- 4 Ange typ och storlek.
- 5 Har ni någon typ av spänningsstabilisering i anläggningen?
- 6 Ange typ.
- 7 Är nätägaren behjälplig vid nätstörningsproblem som inte har en uppenbar orsak?
- 8 Informerar nätägaren om ändrade driftförhållanden i området (till exempel ändrad last på transformatorer)?

### **The questionnaire in English**

#### Electric power distribution

- 1 What voltage level do you subscribe to?
- 2 What voltage levels are present in the network?
- 3 What type of grounding is used in the network? If there are different types for different voltage levels, specify this.
- 5 Is there redundancy in some parts of the network?
- 6 Is five-wire system used in the whole network? If not specify the type of wiring system.
- 7 Indicate your power distributor
- 8 Indicate your owner
- 9 Indicate your maximum load
- 10 Indicate your total energy consumption for one year
- 11 Attach a lay-out of the network

### Disturbances/outages

- 1 How often are you affected by unexpected outages?
- 2 Indicate, if possible, the cause of these outages
- 3 Estimate the length of these outages
- 4 How often do you have planned outages?
- 5 Estimate the length of these outages
- 6 Are you sometimes affected by 'inexplicable' disturbances that could not be explained by external influences?
- 7 If this is the case, estimate the frequency of occurrence
- 8 Do you have trouble with equipment being damaged without explanation or with short life for certain components? What equipment and which components are affected?
- 9 Are you affected by equipment damage in situations you can explain, for example special load situations or by outer influence from some industry nearby?
- 10 Are you aware of nearby industries having the same types of problems as you have?

### Load situation

- 1 What type of loads are fed by the power system (indicate in percentage levels)
  - Constant load
  - Fluctuating load (sec)
    - a. Fluctuating load (min)
    - b. Fluctuating load (hrs)
- 2 Indicate the operational situation
  - c. Daytime operation
  - d. 24 hrs operation
  - e. Other operation, shift operation
- 3 What types of loads are connected to the network
  - f. Motors (medium level voltage)
  - g. Motors (low level voltage)
  - h. Lighting
  - i. Electrical heating
  - j. Load with rectifiers
  - k. Other load (indicate the type)
- 4 Other information about the load

### Preventive actions against disturbances

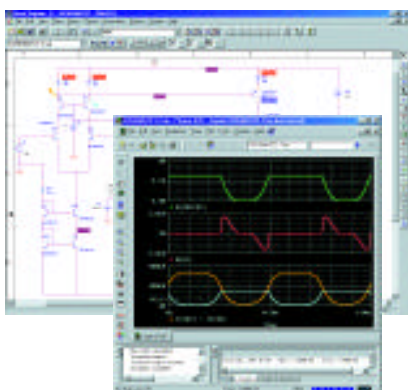
- 1 Do you have reserve power units to support the plant or parts of the plant?
- 2 Indicate type and size
- 3 Are there any filters installed in the plant, for example harmonic reduction or suppression filters?

- 5 Indicate type and size
- 6 Is any control equipment installed in the plant?
- 7 Indicate type
- 8 Is the grid-owner able to help when there are inexplicable disturbances?
- 9 Does the grid-owner inform you about changed situations in the running of the network, for example changed load on transformers?

# PSpice A/D

## ADVANCED SIMULATION SOLUTIONS FOR ANALOG AND MIXED-SIGNAL ENVIRONMENTS

Designers utilize PSpice® simulation solutions for accurate analog and mixed-signal simulations supported by a wide range of board level models. Since the inception of the PSpice simulator in 1985, PSpice has been continuously enhanced by expanding its portfolio of technologies supporting the latest hardware and operating systems. Each subsequent release has addressed numerous technological advances and customer requests for enhancements.



*PSpice provides a complete simulation environment including simulation, waveform analysis with cross-probing, and bias results display on the schematic.*

PSpice® A/D is mature and proven advanced, native mixed-signal simulator and a superset of the core PSpice simulator. Uses range from the need to simulate complex mixed-signal designs, containing both analog and digital parts to supporting models like IGBTs, pulse width modulators, DACs and ADCs. The viewing of simulation results, both analog and digital, has been simplified by having a single display for the mix signal analysis results while retaining the same time axis.

### PRODUCT FEATURES AND BENEFITS

#### DESIGN ENTRY AND EDITING

- Use the advanced capabilities of OrCAD Capture® design entry, or Capture CIS — the world's most popular schematic entry system, to enter your designs
- Select from a library of over 18,000 simulation models, or choose from OrCAD Capture/Capture CIS library of parts for general schematic entry
- Easily import existing PSpice designs, created with MicroSim® Schematics, into the OrCAD Capture/PSpice environment to upgrade your design process

- Navigate through complex designs quickly with the hierarchical browser
- Create hierarchical block diagrams with automatic pin placement on hierarchical blocks
- Wiring of analog and digital components will reflect true signal analysis. The simulator automatically handles the tradeoffs between analog and digital domains
- Cadence® Concept® HDL Expert is also fully integrated with PSpice, including one-button simulation and cross-probing

#### STIMULUS CREATION

- Invoke the interactive, graphical PSpice Stimulus Editor from OrCAD Capture/Capture CIS to define and preview stimulus characteristics
- Access built-in functions that can be described parametrically, or draw piecewise linear (PWL) signals freehand with the mouse to create any shape stimulus
- Create digital stimuli for signals, clocks, and buses; click-and-drag to introduce and move transitions

## CIRCUIT SIMULATION

### ORCAD CAPTURE/PSPICE INTEGRATION

- Set up and run simulations, and cross-probe simulation results from OrCAD Capture/Capture CIS
- Use the hierarchical netlister with parametric subcircuits to expedite netlisting of complex hierarchical designs
- Expanded simulations can be run in the background while you continue editing new or existing designs
- Create multiple simulation profiles and save them in OrCAD Capture/Capture CIS with Project Manager, so you can recall and run different simulations on the same schematic
- View simulation bias results directly on the schematic, including node voltages, pin and subcircuit currents, and device power calculations



Pause a long simulation to run a shorter one. The Simulation Manager shows the current status of the simulations being performed.

### SIMULATION CONTROL

- Monitor simulations runs, view simulation messages along with viewing results, as setup files are edited, all managed from a unified simulation environment
- Utilize analog analysis capabilities such as user-defined accuracy, automatic time-step control, and proprietary convergence algorithms to control the simulation process
- Interactively trade off accuracy and simulation time by loosening tolerances and time steps during non-critical periods of transient analyses, or by extending a transient analysis beyond pre-specified end time
- Preempt the current simulation to immediately run another one, then return to complete the preempted simulation later; control the queue of simulations waiting to be performed

### MIXED ANALOG/DIGITAL SIMULATION

- PSpice A/D automatically recognizes A-to-D and D-to-A signals, and properly simulates them by inserting interface subcircuits and power supplies
- Integrated analog and event-driven digital simulations improve speed without loss of accuracy
- Single graphical waveform analyzer displays mixed analog and digital simulation results on the same time axis
- Digital functions support five logic levels and 64 strengths, load-dependent delays, and hazard/race checking

### ANALOG ANALYSIS

- Explore circuit behavior using basic DC, AC, noise, and transient analyses
- View node voltages, pin currents, and power consumption or noise contributions of individual devices
- Include specific local temperature effects on individual devices for more accurate analyses
- Show circuit behavior variations as components change, via parametric, Monte Carlo, and worst-case analyses

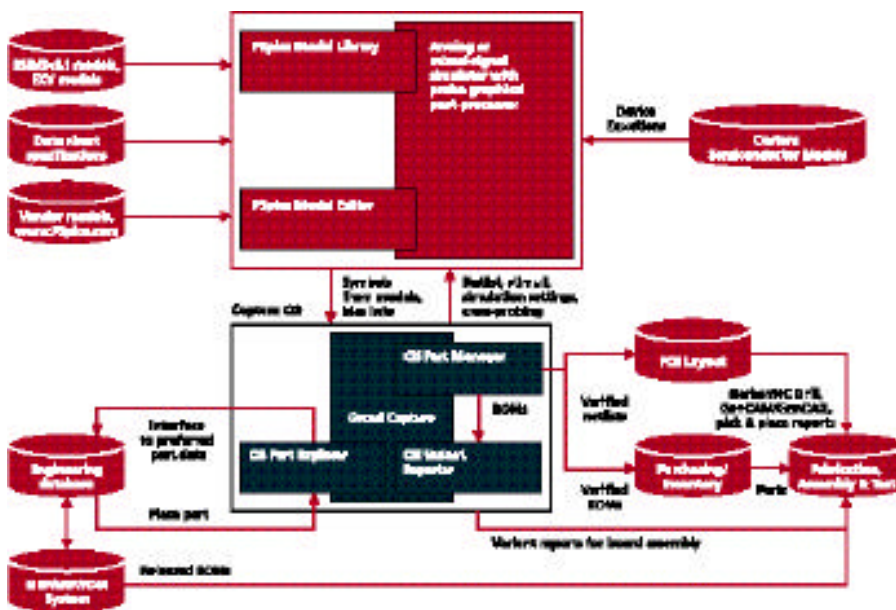
## GRAPHICAL RESULTS

### PROBE WINDOWS

- Choose from an expanded set of mathematical functions to apply to simulation output variables
- View simulation results waveform windows
- Select waveforms by name or by marking a net, pin, or part in the schematic
- Utilize cross-probing markers once and they remain with the analysis. As you change and re-simulate the design, the marked waveforms appear after each simulation
- View continuous, real-time “marching waveforms” as simulation progresses
- Copy and paste high-resolution, scalable waveforms into other applications for producing documentation
- Create plot window templates and use them to easily make complex measurements, just by placing markers on desired pins, nets, and parts in the schematic
- Measure performance characteristics of your circuit using built-in measurement functions or create your own measurements

### DATA DISPLAY

- Plot both real and complex functions of circuit voltage, current, and power consumption including Bode plots for gain and phase margin and derivatives for small-signal characteristics
- Display Fourier transforms of time domain signals or inverse Fourier transforms of frequency domain signals
- Vary component values over multiple runs and quickly view results as a family of waveforms with parametric, Monte Carlo, and worst-case analyses





- Plot waveform characteristics, such as rise time versus temperature or supply voltage, using parametric analysis
- Create histograms after Monte Carlo analyses to display the distribution of a characteristic, such as overshoot

## MODELS

### ACCURATE INTERNAL MODELS

- Large variety of built-in models adds flexibility to your simulations; most include temperature effects
- Shipped models include R, L, C, and bipolar transistors, plus:
  - Built-in IGBTs
  - Seven MOSFET models, including industry standard BSIM3v3.2 and the new EKV 2.6 model
  - Five GaAsFET models, including Parker-Skellern and TriQuint TOM-2 models
  - Nonlinear magnetic models complete with saturation and hysteresis
  - Transmission line models that incorporate delay, reflection, loss, dispersion, and crosstalk
  - Digital primitives, including bi-directional transfer gates with analog I/O models
- Device Equations Developer's Kit (DEDK) allows implementation of new internal model equations which can be used with PSpice\*

### MODEL LIBRARY

- Select from more than 18,000 analog and mixed-signal models of devices made in North America, Japan, and Europe
- More than 4,500 parameterized models for BJTs, JFETs, MOSFETs, IGBTs, SCRs, magnetic cores and toroids, power diodes and bridges, operational amplifiers, optocouplers, regulators, PWM controllers, Multipliers, timers, and sample-and-holds. These models allow passing simulation parameters as properties from the Schematic Editor
- Access basic components plus a variety of macro-models for more complex devices, including operational amplifiers, comparators, regulators, optocouplers, ADCs, and DACs Symbols from Models

### SYMBOLS FROM MODELS

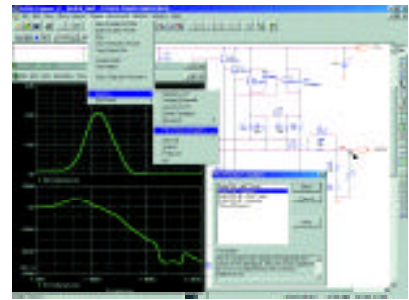
- Automatically generate OrCAD Capture/Capture CIS parts for the models created by the Model Editor
- Automatically generate OrCAD Capture/Capture CIS part libraries from simulation model libraries obtained from part vendors or colleagues
- Base the symbol generation on the PSpice symbol set, or your own
- Generate symbols for analog, digital, or mixed-signal devices (both primitives and macro-models)

### PSPICE MODEL EDITOR

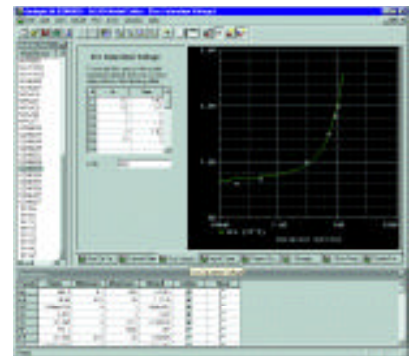
- Click on a part in OrCAD Capture/Capture CIS, and use the intuitive user interface of the PSpice Model Editor to view or edit its simulation model
- Extract a model of a supported device type by simply entering required data from the device's data sheet
- Proceed quickly through the extraction process using fully interactive features to guide you. Device characteristic curves give you quick graphical feedback

### BEHAVIORAL MODELING

- Describe functional blocks using mathematical expressions and functions
- Leverage a full set of mathematical operators, nonlinear functions, and filters
- Implement any transfer function via controlled voltage and current sources
- Define circuit behavior in the time or frequency domain, by formula (including Laplace transforms), or by look-up tables
- Select parameters which have been passed to subcircuits in a hierarchy and insert them into transfer functions
- Create Boolean expressions that reference internal states and pin-to-pin delays using digital behavioral modeling



Use plot window markers to quickly perform common measurements. Choose from the markers provided, or create your own in PSpice.



Use the Model Editor to create new PSpice models based on manufacturers' datasheets.

\* Device Equations Developer's Kit (DEDK) is available by special arrangement with PSpice Technical Support. DEDK is intended for use by experienced device physicists and requires knowledge of C programming.

## **PSPICE A/D KEY FEATURES AND SPECIFICATIONS**

- Graphical design entry with OrCAD Capture/Capture CIS
- New use-model of varying model parameters through property control from OrCAD Capture
- Simulation setup with easy to use dialogs
- Hierarchical netlisting
- Cross-probing with OrCAD Capture/Capture CIS
- Plot window templates
- Probe Windows waveform: viewer and analyzer
- Symbols from models
- Multiple-named simulation profiles
- DC sweep, AC sweep, and transient analysis
- Noise, Fourier, and temperature analysis
- Parametric analysis (STEP)
- Monte Carlo and sensitivity/worst case analysis
- Preemptive simulation
- Interactive simulation control
- Analog behavioral modeling
- Propagation delay modeling for digital gates
- Constraint checking (e.g. setup-and-hold timing)
- Digital worst-case timing
- Charge storage on digital nets
- Stimulus Editor (STIMULUS and STIMLIB)
- Model Editor for device characterization
- Measurements and Performance Analysis
- Save/load bias point (.SAVEBIAS/LOADBIAS)
- Power measurement with crossprobing
- Two simulation engines
- GaAsFETs: Curtice, Statz, TriQuint, Parker-Skellern
- MOSFETs: SPICE3 (1-3 with charge conservation)
- MOSFETs: BSIM1, BSIM3 (versions 2 and 3.2), EKV 2.6
- IGBTs
- Darlingtons
- DACs and ADCs

- JFETs, BJTs
- OPAMPs, Regulators
- PWMs
- Resistor, capacitor, and inductor .MODEL support
- Ideal and non-ideal lossy transmission lines
- Coupled transmission lines
- Coupled inductors
- Nonlinear magnetics
- Voltage and current-controlled switches
- 5,000 additional parts built over parameterized templates that include discrete, linear, controllers, and magnetics models
- Analog model library with over 16,000 models
- Analog parameterized model library with over 4,500 models
- Digital primitives
- Digital model library with over 2000 models
- Device equations support

## **SYSTEM REQUIREMENTS**

- Pentium® II 300 MHz PC (or faster)
- Windows® XP Professional, Windows® XP Home Edition, Windows® 2000 (SP2 or higher), or Windows® NT 4.0 (SP6A or higher)
- Minimum 64 MB RAM
- 256 MB swap space
- 256-color Windows® display driver with a minimum of 800 x 600 resolution (1024 x 768 recommended)

## **SALES, TECHNICAL SUPPORT AND TRAINING**

The OrCAD product line is owned by Cadence Design Systems Inc., and supported by a worldwide network of value-added (VARs) resellers or distributors. For sales, technical support and training, contact your local VAR. For a complete list of authorized VARs, visit [www.orcad.com](http://www.orcad.com)

## **PRICING INFORMATION**

For product pricing and availability, contact the OrCAD VAR nearest you. To locate a VAR in your area, visit [www.orcad.com](http://www.orcad.com)



©2003 Cadence Design Systems, Inc. All rights reserved. In the U.S. and numerous other countries, OrCAD, OrCAD Capture, OrCAD Layout, OrCAD Unison suite, PSpice, SPECCTRA, Cadence, and the OrCAD logo are registered trademarks of Cadence Design Systems, Inc. All others are properties of their holders.

Stock #4422 2/03